

HMP155 Humidity and Temperature Probe



HMP155 with a new, stable HUMICAP®180R sensor and an additional temperature probe.

Features/Benefits

- Vaisala HUMICAP®180R sensor - superior long-term stability
- Optional warmed humidity probe
- Plug-and-play
- Chemical purge
- USB connection for service use
- Installation kits for DTR13 and DTR502 radiation shields and also for a Stevenson screen
- Weather-proof housing IP66
- New, fast temperature probe
- Different output possibilities: voltage, RS-485, resistive Pt100
- Applications: meteorological applications, aviation and road weather, instrumentation

New probe for reliability

The new Vaisala HUMICAP® Humidity and Temperature Probe HMP155 provides reliable humidity and temperature measurement.

Long-term stability

The HMP155 has a new generation Vaisala HUMICAP®180R sensor that has excellent stability and withstands well harsh environments. The probe structure is solid and the sensor is protected with a sintered teflon filter, which gives maximum protection against liquid water, dust, and dirt.

Warmed probe and high humidity environment

Measuring humidity reliably is challenging in environments where humidity is near saturation. Measurements may be corrupted by fog, mist, rain, and heavy dew. A wet probe may not give an accurate measurement in the ambient air.

This is an environment to which Vaisala has designed a patented, warmed

probe for reliable measuring. As the sensor head is warmed continuously, the humidity level inside it stays below the ambient level. Thus, it also reduces the risk of condensation forming on the probe.

Fast temperature measurement

What's more, with its fast response time, the additional temperature probe for the HMP155 is ideal for measurement in environments with changing temperatures.

Long lifetime

Protecting the sensor from scattered and direct solar radiation, and precipitation will increase its lifetime. Thus, Vaisala recommends installing the HMP155 in one of the following radiation shields: DTR503, DTR13, or a Stevenson screen.

Easy maintenance

The probe can be calibrated using a pc with a USB cable, with the push buttons, or with the MI70 indicator.

Applications

The HMP155 is especially designed for use in meteorological applications, such as synoptic and hydrological weather stations, aviation, and road weather. It is also suitable in a wide range of instrumentation, for example, recorders, data loggers, and laboratory equipment and monitoring.

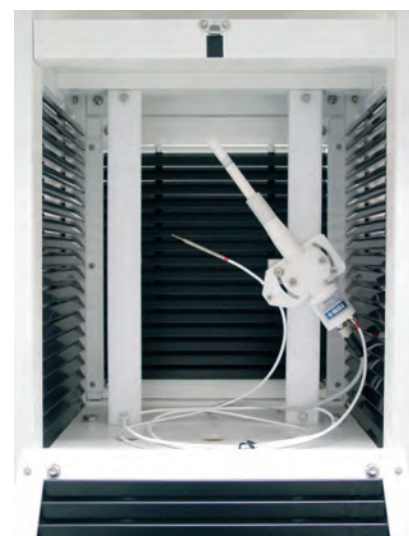

HMP155 in a Stevenson screen.

Technical Data

Performance

Relative humidity	
Measurement range	0 ... 100 % RH
Accuracy (incl. non-linearity, hysteresis and repeatability) at	
+15 ... +25 °C (+59 ... +77 °F)	±1 %RH (0 ... 90 %RH) ±1.7 %RH (90 ... 100 %RH)
-20 ... +40 °C (-4 ... 104 °F)	±(1.0 + 0.008 x reading) %RH
-40 ... -20 °C (-40 ... -4 °F)	±(1.2 + 0.012 x reading) %RH
+40 ... +60 °C (+104 ... +140 °F)	±(1.2 + 0.012 x reading) %RH
+60 ... -40 °C (-76 ... -40 °F)	±(1.4 + 0.032 x reading) %RH
Factory calibration uncertainty (+20 °C / +68 °F)	±0.6 %RH (0 ... 40 %RH)* ±1.0 %RH (40 ... 97 %RH)*
* Defined as ±2 standard deviation limits. Small variations possible, see also calibration certificate.	
Recommended humidity sensor	HUMICAP® 180R(C)

Response time at +20 °C in still air with a sintered PTFE filter	
63 %	20 s
90 %	60 s

Temperature

Measurement range	-80 ... +60 °C (-112 ... +140 °F)
Accuracy with voltage output at	
-80 ... +20 °C	±(0.226 - 0.0028 x temperature) °C
+20 ... +60 °C	±(0.055 - 0.0057 x temperature) °C
passive (resistive) output according to IEC 751 1/3 Class B	±(0.1 + 0.00167 x temperature) °C
RS485 output	
-80 ... +20 °C	±(0.176 - 0.0028 x temperature) °C
+20 ... +60 °C	±(0.07 - 0.0025 x temperature) °C
Accuracy over temperature range (see graph below)	

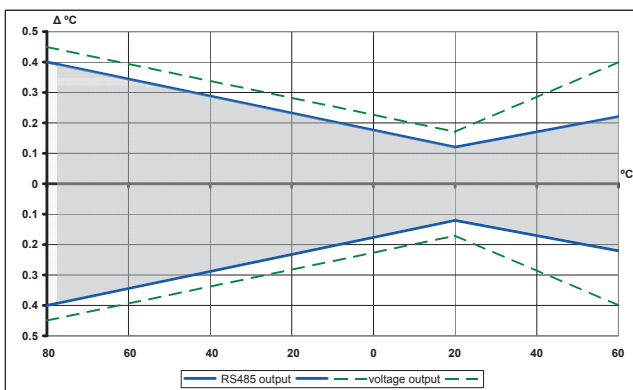

Temperature sensor	Pt100 RTD 1/3 Class B IEC 751
Response time with additional temperature probe in 3 m/s air flow	
63 %	<20 s
90 %	<35 s

Other variables

dewpoint/frost point temperature,
wet bulb temperature, mixing ratio

General

Operating temperature range	-80 ... +60 °C (-112 ... +140 °F)
Storage temperature range	-80 ... +60 °C (-112 ... +140 °F)
Connection	8-pin male M12 connector
Connection cables	3.5, 10, and 30 m
Cable material	PUR
Wire size	AWG26
Service cables	USB connection cable MI70 connection cable
Additional T probe cable length	2 m
Housing material	PC
Housing classification	IP66
Sensor protection	sintered PTFE
Weight (probe)	86 g
Electromagnetic compatibility: Complies with the EMC standard EN61326-1, Electrical equipment for measurement control and laboratory use - EMC requirement for use in industrial locations	

Inputs and outputs

Operating voltage	7 ... 28 VDC*
*Note: minimum operating voltage 12 V with 0 ... 5 V output and 16 V with 0 ... 10 V output, probe heating, chemical purge or XHEAT.	
Outputs	
voltage output	0 ... 1 V, 0 ... 5 V, 0 ... 10 V
resistive Pt100 (4-wire connection)	
RS485	
Average current consumption (+15 VDC, load 100 kOhm)	
0 ... 1 V output	<3 mA
0 ... 10 V output	+0.5 mA
RS485	<4 mA
during chemical purge with warmed probe	max. 110 mA max. 150 mA
Settling time at power-up	
voltage output	2 s
RS485	3 s

Dimensions

Probe
Additional T probe

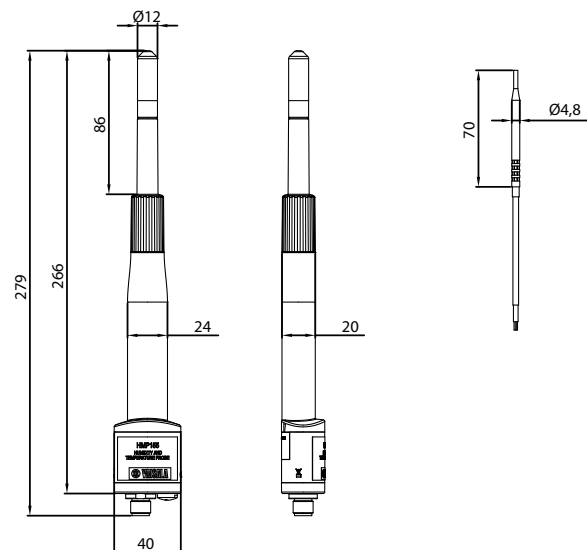

HUMICAP® is a registered trademark of Vaisala.
Specifications are subject to change without prior notice.
©Vaisala Oyj

