

# SATRON VV pressure transmitter

BLV810  
March 1, 2008

**SATRON VV pressure transmitter** belongs to V-transmitter family. The series V transmitters have both analog and smart properties. SATRON VV is used for 0-1,4 kPa...0-0.2 MPa ranges. The transmitter communicates in a 2-wire system. SATRON VV pressure transmitter is suitable for liquid level measurements in ground and rock tanks, and in open channels and ships' tanks. SATRON VV pressure transmitter can be used in corrosive conditions and to measure contaminating liquids. Possible foam on the surface of the measured liquid does not disturb the measurement. SATRON VV does not require compressed air supply. The transmitter's sensor is piezoresistive. The rangeability is 25:1. The transmitter communicates digitally using the HART® protocol.



## TECHNICAL SPECIFICATIONS

### Measuring range and span

See Selection Chart.

### Zero and Span adjustment

Zero elevation: Calibrated span is freely selectable on the specified range depending from the desired option. This can be made by using external control shafts (analog option), keyboard (display option) or HART®275 communicator.

### Damping

Time constant is continuously adjustable 0,01 to 60 s.

### Temperature limits

Process: -10 to +80 °C

Ambient: -30 to +80 °C

Shipping and storage: -40 to +80 °C.

Equipment cabinet is recommended for extremely demanding conditions.

### Pressure limits

Min. and max. process pressure: See the appended tables.

**Output** 2-wire (2W), 4-20 mA, user selectable for linear, square root, inverted signal or the transfer function (16 points) specified by the user

### Supply voltage and permissible load

See the load capacity diagram; 4-20 mA output: 12-35 VDC.

**Humidity limits** 0-100 % RH; freezing of condensed water not allowed in reference pressure channels.

## PERFORMANCE SPECIFICATIONS

Tested in accordance with IEC770: Reference conditions, specified span, no range elevation, AISI316L diaphragm, silicone oil fill.

### Accuracy

- ±0.1 % of calibrated span (span 1:1-7.5:1 / max. range).  
On the measuring ranges 7.5:1-25:1:  
$$\pm [0.01 + 0.012 \times (\frac{\text{max. span}}{\text{calibrated span}})] \% \text{ of calibrated span}$$

(incl. nonlinearity, hysteresis and repeatability)

### Long-term stability

±0.1 % of max. span per 12 months

### Temperature effect on compensated temperature ranges

Zero and span shift: ±0.15 % of max. span

### Mounting position effect

Zero error <0.32 kPa, which can be calibrated out.

### Vibration effect (IEC 68-2-6: FC):

±0.1 % of measuring range/

2 g/10 to 2000 Hz

4 g/10 to 100 Hz

### Power supply effect

<±0.01 % of calibrated span per volt.

### EMC-test standards

Electro Magnetic Compatibility (EMC) (89/336/ETY)

### Insulation test voltage

500 V rms 50 Hz.

## CONSTRUCTION AND CALIBRATION

### Materials

Diaphragm <sup>1)</sup>: AISI316L, Hast. C276 or Tantalum.

Sensing element <sup>1)</sup>: AISI316, PTFE/ AISI316 or PVC

Other materials: SIS2343

**Fill fluid** Silicone oil or inert oil.

### Housing with PLUG connector, codes H and T

Housing: AISI316

Seals: Viton® and NBR

TEST jacks: MS358Sn/PVDF, protected with silicone rubber shield. PLUG connector: PA6-GF30 jacket, Silicone rubber seal, AISI316 retaining screw.

### Housing with junction box/terminal strip, codes M and N

Housing: AISI303/316; Seals: Nitrile and Viton®; Nameplates: Polyester  
**Connection cable between sensing element and housing** (code Land K): PTFE hose with AISI316 braiding.

**Equipment cabinet** Rittal AE1380, Steel cabinet with polyester paint.

**Enclosure class:** IP66.

### Calibration

For customer-specified range with minimum damping. (If range is not specified, transmitter is calibrated for maximum range.)

<sup>1)</sup> Parts in contact with process medium

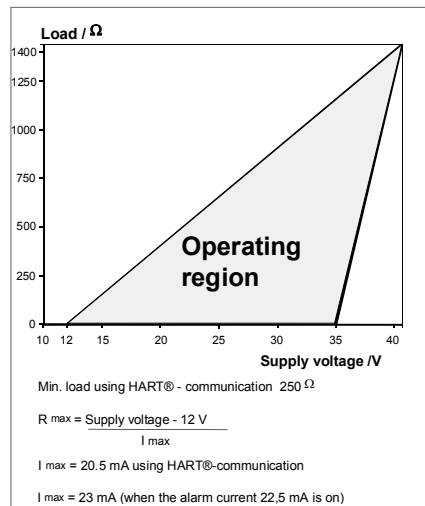

### Electrical connections

Housing with PLUG connector, codes H and T: PLUG connector, connector type DIN 43650 model AF; Pg9 gland for cable; wire gross-section 0.5 to 1.5 mm<sup>2</sup>.

Housing with junction box/terminal strip, codes M and N:

M20x1.5, 1/2-NPT inlet; screw terminals for 0.5 to 2.5 mm<sup>2</sup> wires.

### Process connections

DN50PN40, DN80PN40, ANSI2" 150 lbs/300 lbs, ANSI3" 150 lbs/300 lbs; clamp mounting on angle bracket (see INSTALLATION)

### Weight (kg):

- VVF 2.2 kg
- VVP 8.7 kg
- VVH 9.2 kg
- + 1 kg/m with PVC protective tube and 3 kg/m with AISI316 protective tube.

Pressure limits			Minimum process pressure		
Maximum process pressure, MPa			Minimum process pressure for different fill fluids (kPa, abs.)		
Transmitter type	Max. overload pressure	Pressure class	T <sub>proc.</sub> °C	DC200 100 cSt	Inert oil
VV...3	0,2	PN40	20	5	8
VV...4	0,3	PN40	40	8	10
VV...5	1,5	PN40	80	16	28

**Product Certifications**

**European Directive Information**

**Atex Directive (94/9/EC)**

Satron Instruments Inc. complies with the ATEX Directive.

**European Pressure Equipment Directive (PED) (97/23/EC)**

All Pressure Transmitters :  
- Sound Engineering Practice

**Hazardous Locations Certifications**

**European Certifications**

ATEX Intrinsic Safety

Certification No. : DNV-2007-OSL-ATEX- 1346X

 II 1 GD T135°C EEx ia II C T4 - 20°C ≤ Tamb ≤ 50°C

 II 2 GD T135°C EEx ia II C T4 - 20°C ≤ Tamb ≤ 50°C

Input Parameters :

$U_i = 28 \text{ V}$

$I_i = 93 \text{ mA}$

$P_i = 0.651 \text{ W}$

$C_i = 5 \text{ nF}$

$L_i = 0.2 \text{ mH}$

**Special Conditions for Safe Use (X) :**

The enclosure with plastic window and the plastic DIN43650 connector must not be installed in potentially explosive atmosphere requiring category 1 apparatus.

The non-conducting surface of the sensor element may be charged by the flow of non-conducting media, so there may be electrostatic hazard with IIC-gases. These units should be marked 2 GD.

The equipment shall be installed and connected according to the manufacturers instructions.

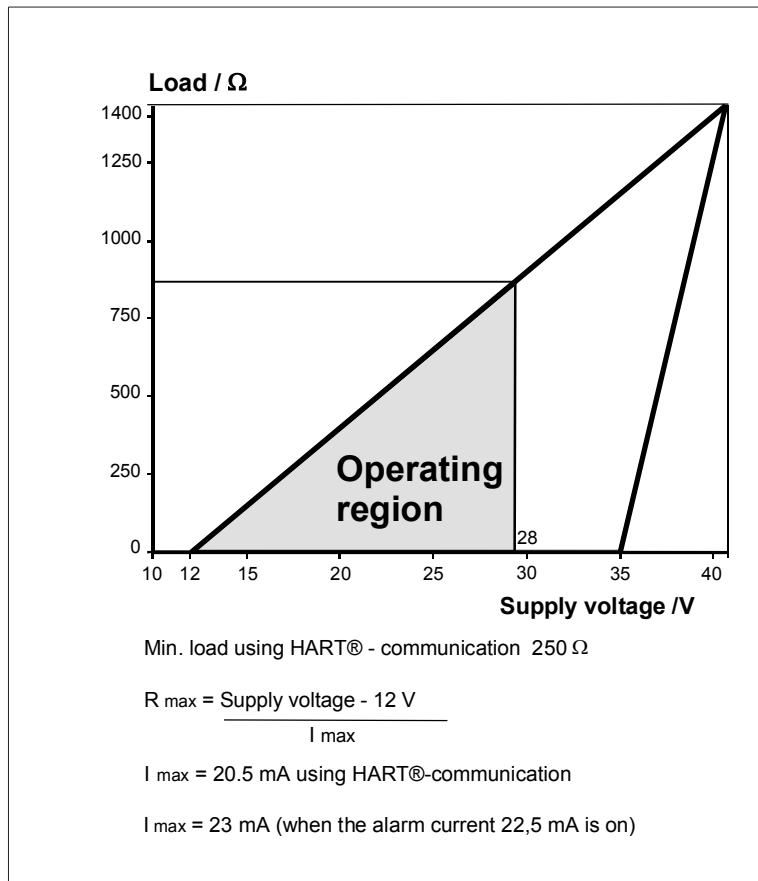

## Dimensional drawings (drawings in mm)

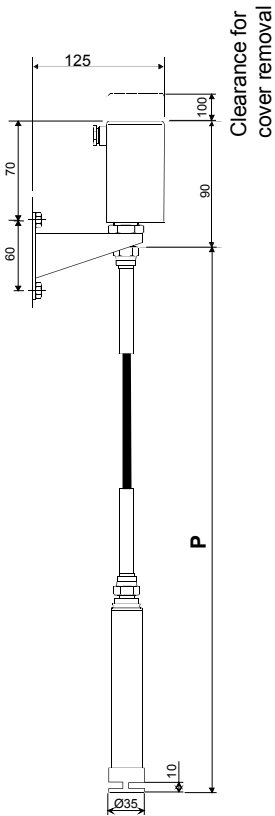

Type VVF

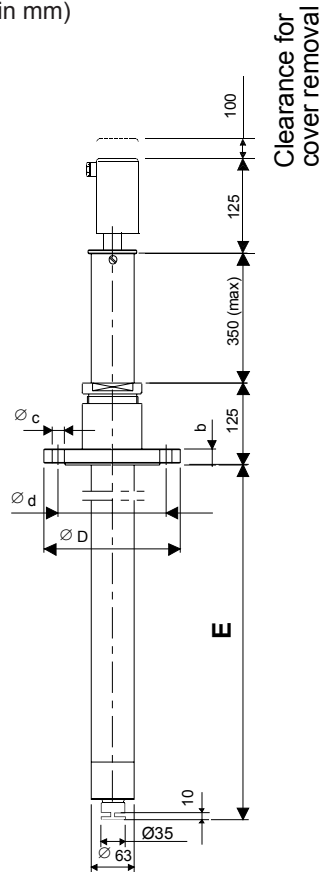

Type VVP

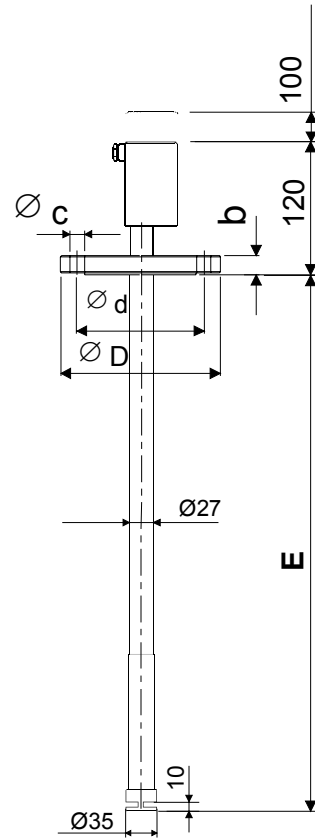

Type VVH

Clearance for cover removal  
Atex transmitter code1, housing length +15

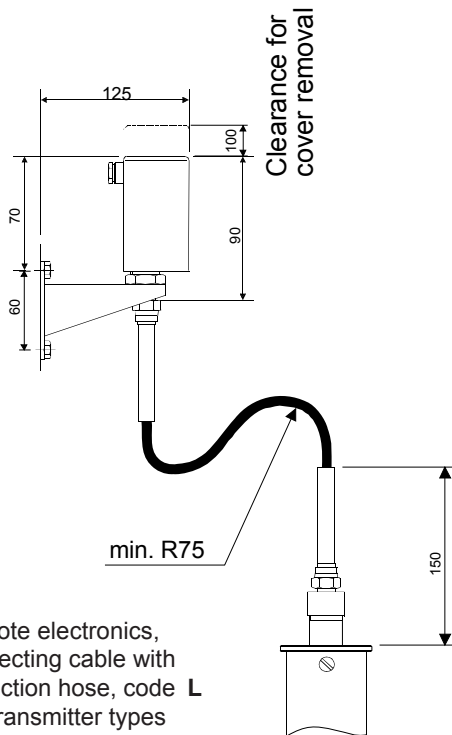

Remote electronics, connecting cable with protection hose, code L (for transmitter types VVP and VVH)

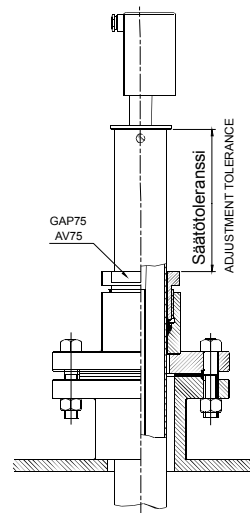

Flange mounting with adjustment facility, type VVP

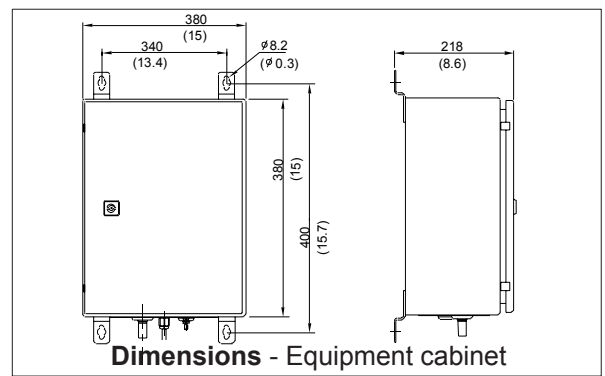

Dimensions - Equipment cabinet

Type	P/m		E/m	
	min.	max.	min.	max.
VVF	1.0	20.0	-	-
VVP	-	-	1.0	5.5
VVH	-	-	1.0	5.5

Flange	Code	ØD	Ød	Øc	b
DN50 PN40	DB	165	125	4x18	20
DN80 PN40	DC	200	160	8x18	24
ANSI2"150lb	AC	152	120.6	4x20	23
ANSI2"300lb	AD	165	127	8x20	25
ANSI3"150lb	AE	191	152.4	4x20	26
ANSI3"300lb	AF	210	168.3	8x23	31

# SATRON VV pressure transmitter

## Installation methods

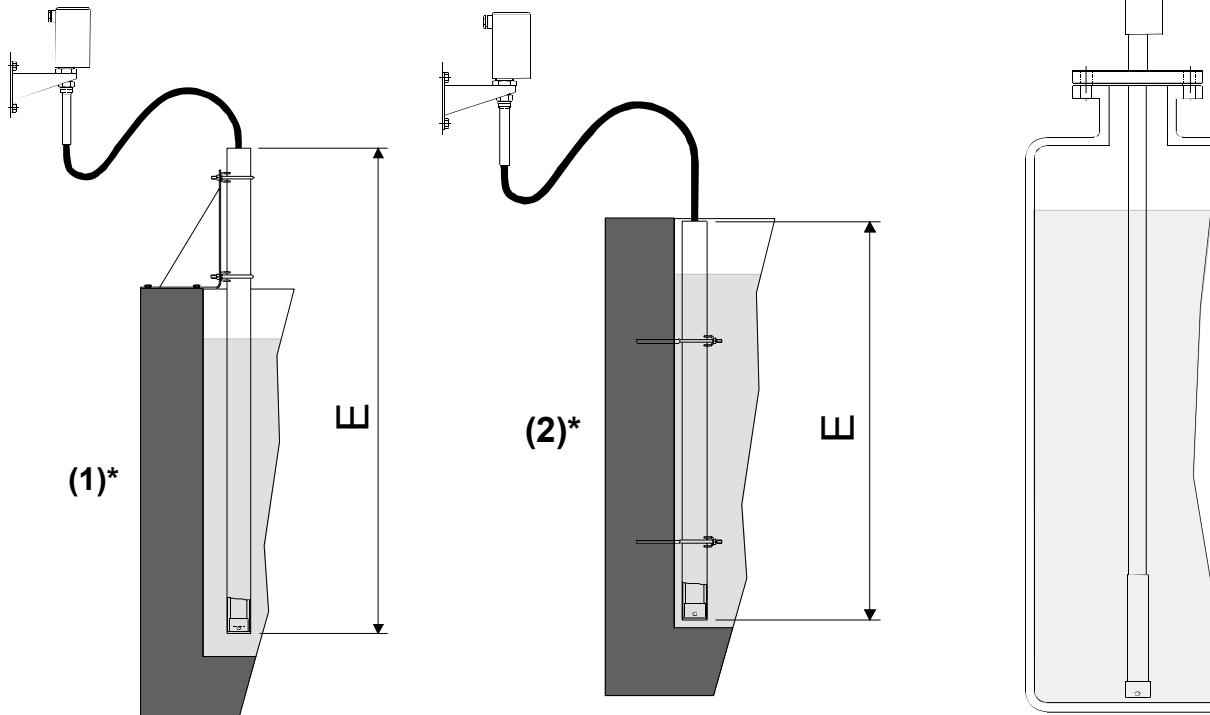

\*) See the selection table "Other mounting accessories"

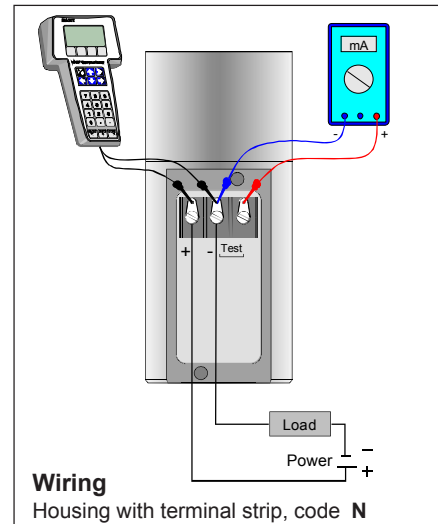
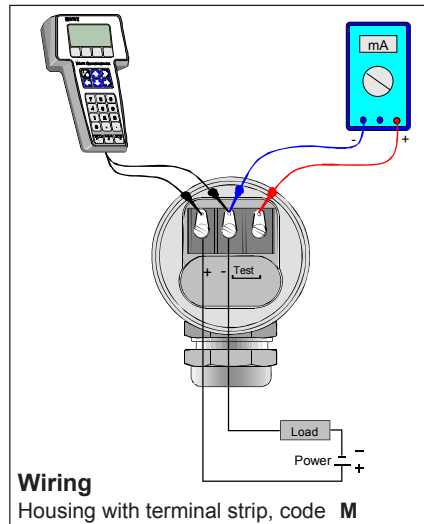
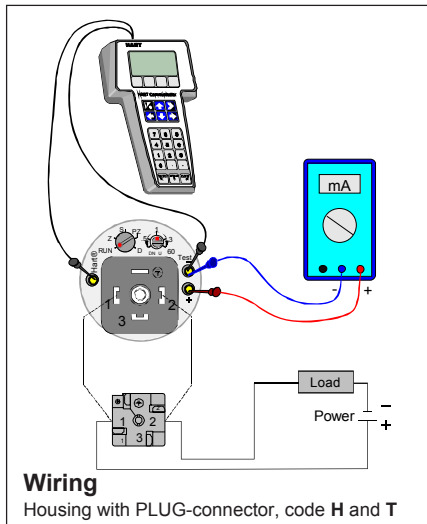

**Housing with display, code N**

Keyboard :

- Esc** = Press **Esc** to move back towards the top of the main menu.
- ▲** = Use the UP arrow key to move up on the current menu level or to increase the selected parameter value.
- ▼** = Use the DOWN arrow key to move down on the current menu level or to decrease the selected parameter value.
- Enter** = Press **Enter** to move to a lower level in a menu or to accept a command or parameter value.

**Housing with PLUG-connector, code T**

Use of selector switch :

- RUN** = Working position
- PZ** = Process value zero
- D** = Damping adjustment
- S** = Span adjustment
- Z** = Zero adjustment
- DN** = Down
- UP** = Up

