

PTB330 Digital Barometer for Professional Meteorology, Aviation, and Industrial Users

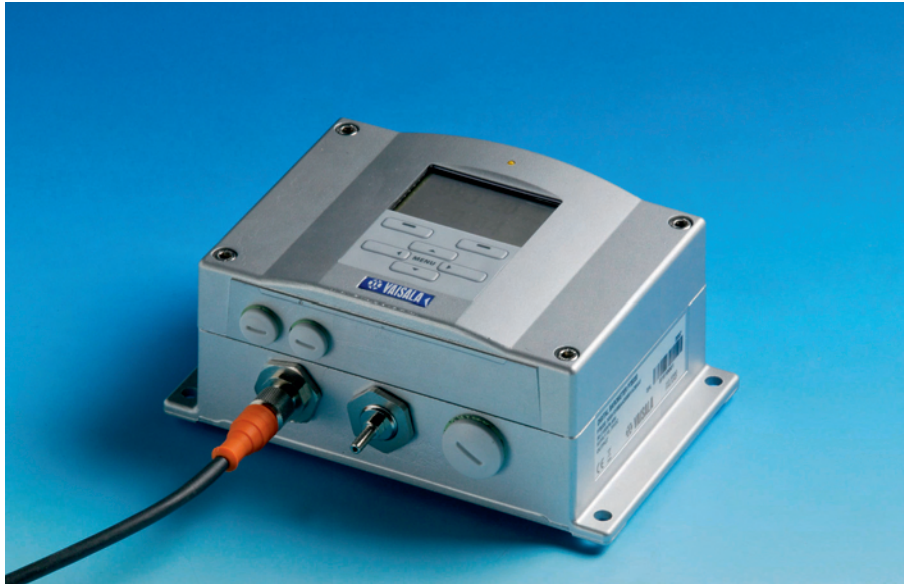

Features/Benefits

- Vaisala BAROCAP® sensor
- Accurate measurement
- Excellent long-term stability
- Added reliability through redundancy
- Graphical trend display with 1-year history data
- Height and altitude corrected pressure (QFE, QNH)
- For professional meteorology and aviation, laboratories, demanding industrial applications

Vaisala BAROCAP® Digital Barometer PTB330 with a new trend display.

Vaisala BAROCAP® Digital Barometer PTB330 is a new generation barometer, designed for a wide range of high-end atmospheric pressure measurement.

The pressure measurement of the PTB330 is based on the Vaisala in-house, silicon capacitive, absolute pressure sensor - the Vaisala BAROCAP® Sensor. It provides high measurement accuracy and excellent long-term stability.

High accuracy

The PTB330 series features extremely high accuracy. Class A barometers for the most demanding applications are fine-adjusted and calibrated against a deadweight tester. Class B barometers are adjusted and calibrated using electronic working standards. All the PTB330 barometers come with a NIST traceable, factory calibration certificate.

Reliability through redundancy

According to customers' choice, the PTB330 can incorporate one, two or

three BAROCAP® sensors. When two or three sensors are used, the barometer continuously compares the readings of the pressure sensors against one another and provides information on whether these are within the set internal difference criteria. This unique feature provides redundancy in pressure measurement.

Thus, users also get a stable and reliable pressure reading at all times as well as a pre-indication of when to service or recalibrate the barometer.

In addition to instant pressure, the PTB330 also provides the WMO pressure trend and tendency code.

QNH and QFE

The PTB330 can be set to compensate for QNH and QFE pressure used especially in aviation. The QNH represents the pressure reduced to sea level, based on the altitude and temperature of the observation site. The QFE represents the height corrected pressure of small differences

in altitude, for example, the air pressure at the airfield elevation.

Data transfer

The data can be transferred to a PC by using MI70 Link Interface Software. You can examine the recorded data easily in a Microsoft® Windows environment and transfer it further to a spreadsheet program, such as Microsoft® Excel, in numeric or graphical format.

Graphical display

The PTB330 features a multi-lingual, graphical display allowing users to monitor measurement trends. The graph is updated automatically while measuring and it provides a one-year measurement history.

Applications

The PTB330 can be used successfully for aviation, professional meteorology, and for demanding industrial pressure measurement applications such as accurate laser interferometric measurement and exhaust gas analysis in engine test benches.

Technical Data

Performance

Barometric pressure range 500 ... 1100 hPa

	Class A	Class B
Linearity*	±0.05 hPa	±0.10 hPa
Hysteresis*	±0.03 hPa	±0.03 hPa
Repeatability*	±0.03 hPa	±0.03 hPa
Calibration uncertainty**	±0.07 hPa	±0.15 hPa
Accuracy at +20 °C (+68 °F) ***	±0.10 hPa	±0.20 hPa

Barometric pressure range 50 ... 1100 hPa

	Class B
Linearity*	±0.20 hPa
Hysteresis*	±0.08 hPa
Repeatability*	±0.08 hPa
Calibration uncertainty**	±0.15 hPa
Accuracy at +20 °C ***	±0.20 hPa

Temperature dependence****

500 ... 1100 hPa	±0.1 hPa
50 ... 1100 hPa	±0.3 hPa

Total accuracy -40 ... +60 °C (-40 ... +140 °F)

	Class A	Class B
500 ... 1100 hPa	±0.15 hPa	±0.25 hPa
50 ... 1100 hPa		±0.45 hPa

Long-term stability

500 ... 1100 hPa	±0.1 hPa/year
50 ... 1100 hPa	±0.1 hPa/year

* Defined as ±2 standard deviation limits of endpoint non-linearity, hysteresis or repeatability error.

** Defined as ±2 standard deviation limits of inaccuracy of the working standard including traceability to NIST.

*** Defined as the root sum of the squares (RSS) of endpoint non-linearity, hysteresis error, repeatability error and calibration uncertainty at room temperature.

**** Defined as ±2 standard deviation limits of temperature dependence over the operating temperature range.

Operating environment

Pressure range	500 ... 1100 hPa, 50 ... 1100 hPa
Temperature range operating	-40 ... +60 °C (-40 ... +140 °F)
with local display	0 ... +60 °C (+32 ... +140 °F)

Inputs and outputs

Supply voltage	10 ... 35 VDC
Supply voltage sensitivity	negligible
Typical power consumption at +20 °C (U _i 24 VDC, one pressure sensor)	
RS-232	25 mA
RS-485	40 mA
U _{out}	25 mA
I _{out}	40 mA
display and backlight	+20 mA
Serial I/O	RS232C, RS485/422
Pressure units	hPa, mbar, kPa, Pa inHg, mmH ₂ O, mmHg, torr, psia
	Class A Class B
Resolution	0.01 hPa 0.1 hPa
Settling time at power-up (one sensor)	4 s 3 s
Response time (one sensor)	2 s 1 s
Acceleration sensitivity	negligible
Pressure connector	M5 (10-32) internal thread

Pressure fitting	barbed fitting for 1/8" I.D. tubing or quick connector with shutoff valve for 1/8" hose
Maximum pressure limit	5000 hPa abs.
Compliance	EMC standard EN61326-1:1997+ Am1:1998 + Am2:2001: Industrial Environment

Mechanics

Housing material	G AlSi10 Mg (DIN 1725)
Housing classification	IP65
Weight	1 - 1.5 kg

Analog output (optional)

Current output	0 ... 20 mA, 4 ... 20 mA
Voltage output	0 ... 1 V, 0 ... 5 V, 0 ... 10 V
Accuracy at pressure range	500 ... 1100 hPa 50 ... 1100 hPa
	at +20 °C ±0.30 hPa ±0.40 hPa
	at -40 ... +60 °C ±0.60 hPa ±0.75 hPa

Accessories

Serial interface cable	19446ZZ
USB-RJ45 serial connection cable	219685
Software interface kit	215005
Wall mounting kit	214829
Outdoor installation kit (weather shield)	215109
Installation kit for pole or pipeline	215108
Power supply module	POWER-1
Temperature compensated analog output module	AOUT-1T
Isolated RS-485 module	RS485-1

Dimensions

in mm (inches)

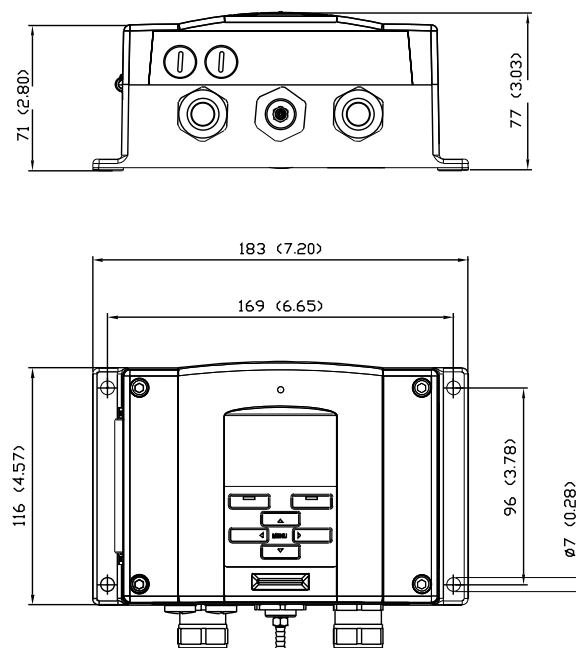

BAROCAP® is a registered trademark of Vaisala.
Specifications are subject to change without prior notice.
©Vaisala Oyj

