

SATRON VDU differential pressure transmitter belongs to V-series transmitters. SATRON VDU differential pressure transmitter is 2-W transmitter and is used from 0-1.4 kPa to 0-3 MPa ranges. In pressure measuring applications SATRON VDU diff. pressure transmitters are used for measuring the pressure of clean, sedimenting, crystallizing and sticking materials. The transmitter's sensor is piezoresistive. The rangeability is 25:1. The transmitter communicates digitally using the HART® protocol.



TECHNICAL SPECIFICATIONS

Measuring range and span

See Selection Chart.

Zero and Span adjustment

Zero elevation: Calibrated span is freely selectable on the specified range. This can be made by using keyboard or HART®275 communicator.

Damping

- Time constant is continuously adjustable 0,01 to 60 s.

Temperature limits

Ambient: -30 to +80 °C

Process: -30 to +125/+200 °C

Shipping and storage: -40 to +80 °C.

Pressure limits Min. and max. process pressure: See the appended tables.

Volumetric displacement

< 0.5 mm³/max. span (in both sensors)

Output 2-wire (2W), 4-20 mA, user selectable for linear, square root, inverted signal or the transfer function (16 points) specified by the user

Supply voltage and permissible load

See the load capacity diagram;

4-20 mA output: 12 - 35 VDC.

Humidity limits

0-100 % RH; freezing of condensed water not allowed in reference pressure channels.

PERFORMANCE SPECIFICATIONS

Tested in accordance with IEC770:

Reference conditions, specified span, no range elevation, horizontal mounting;

O-ring seals, AISI316L diaphragm, silicone oil fill.

Accuracy

±0.2 % of calibrated span

(span 1:1-7.5:1 /max.range).

On the measuring ranges 7.5:1-25:1:

$$\pm[0.02+0.024 \times \left(\frac{\text{max. span}}{\text{calibrated span}} \right)]\% \text{ of calibrated span}$$

Special accuracy types **BA** and **DA** :

(Temperature effect on +20 to +70 °C)

±0,15 % of calibrated span, only process connections **BA** and **DA** / temperature effect code **S**, for spans 1:1-7,5:1).

On the measuring ranges 7,5:1-25:1:

$$\pm[0.01+0.007 \times \left(\frac{\text{max. span}}{\text{calibrated span}} \right)]\% \text{ of calibrated span}$$

(incl. nonlinearity, hysteresis and repeatability)

Long-term stability

±0.2 % / max. span / year

Temperature effect

- on -20 to +80 °C range

Zero and span error:

±0.3 % of max. span.

- on 0 °C to +200 °C range

(process temperature code **H**)

±2 % of max. span, VDU6

±4 % of max. span, VDU4, VDU5

Temperature effect

- on +20 °C to +70 °C,

process connections **BA** and **DA**

Zero and span error:

±0.15 % of max. span, code **S**

Mounting position effect

Zero error < 0.32 kPa, which can be calibrated out.

Vibration effect (IEC 68-2-6: FC):

±0.1 % of measuring range/

2g/10 to 2000 Hz

4g/10 to 100 Hz

Power supply effect

< ±0.01 of calibrated span per volt

EMC-test standards

GENERIC EMISSION STANDARD:

EN 50081 - 2: 1993

Normative reference:

EN 55022:1987/class A

GENERIC IMMUNITY STANDARD:

EN 50082 - 2: 1995

Normative references:

EN 61000-4-2, -4, -5, -8, -11

ENV 50140, ENV 50204, ENV 50141

Insulation test voltage

500 V rms 50 Hz

CONSTRUCTION AND CALIBRATION

Materials

Diaphragm ¹⁾: AISI316L, Duplex (Wnr. 1.4462), Hast. C276/C22, CoNi-alloy, Titanium, Nickel or Tantalum.

Coupling ¹⁾: AISI316L, Duplex (Wnr. 1.4462), Hast.C276 or Titanium

Other sensing element materials: AISI316, AISI303.

Filling fluid: Silicone oil, food industry oil or inert oil

Enclosure class IP66

Electronics housing:

AISI316, Seals: nitrile rubber and Viton®, Nameplates: Polyester

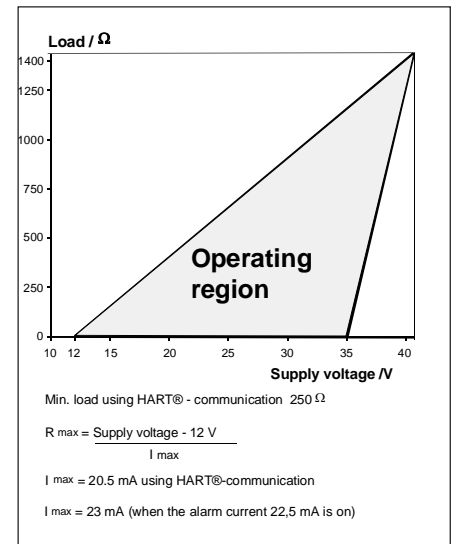

Pressure limits

Maximum process pressure

Transmitter type	Max. overload pressure, MPa	Pressure class
VDU3	0.25	PN40
VDU4	0.3	PN40
VDU5	1.5	PN40
VDU6	7.5	PN100

Minimum process pressure

T _{proc.} °C	Minimum pressure for different fill fluids (kPa, abs.)	
	DC200 100 cSt	Inert oil
20	5	8
40	8	10
80	16	28
120	21	53

¹⁾ Parts in contact with process medium

Calibration

For customer-specified range with minimum damping. (If range is not specified, transmitter is calibrated for maximum range.)

Electrical connections

M20x1.5, 1/2-NPT ; screw terminals for 0.5 to 2.5 mm² wires

Weight

Mounting type	Weight / kg				
	Extension code				
	0	2	4	6	
Flange	DN50	8.8	10	10.5	11
	DN80	13.5	15.8	16	16.8
SA (Sandvik)	-	8.2	10.6	12.8	
Tx (Tri-Clamp)	2.4	-	-	-	
PA (PMC 1")	1.8	-	-	-	
BA (M45x2)	1.8	-	-	-	
UA (Varivent)	2.6	-	-	-	
G1...G4	2.5	-	-	-	

Process connections

G1 connecting thread
Process couplings: See Selection Chart and installation instructions or technical specification: Couplings for Transmitters **G150**.

Dimensions
(mm)

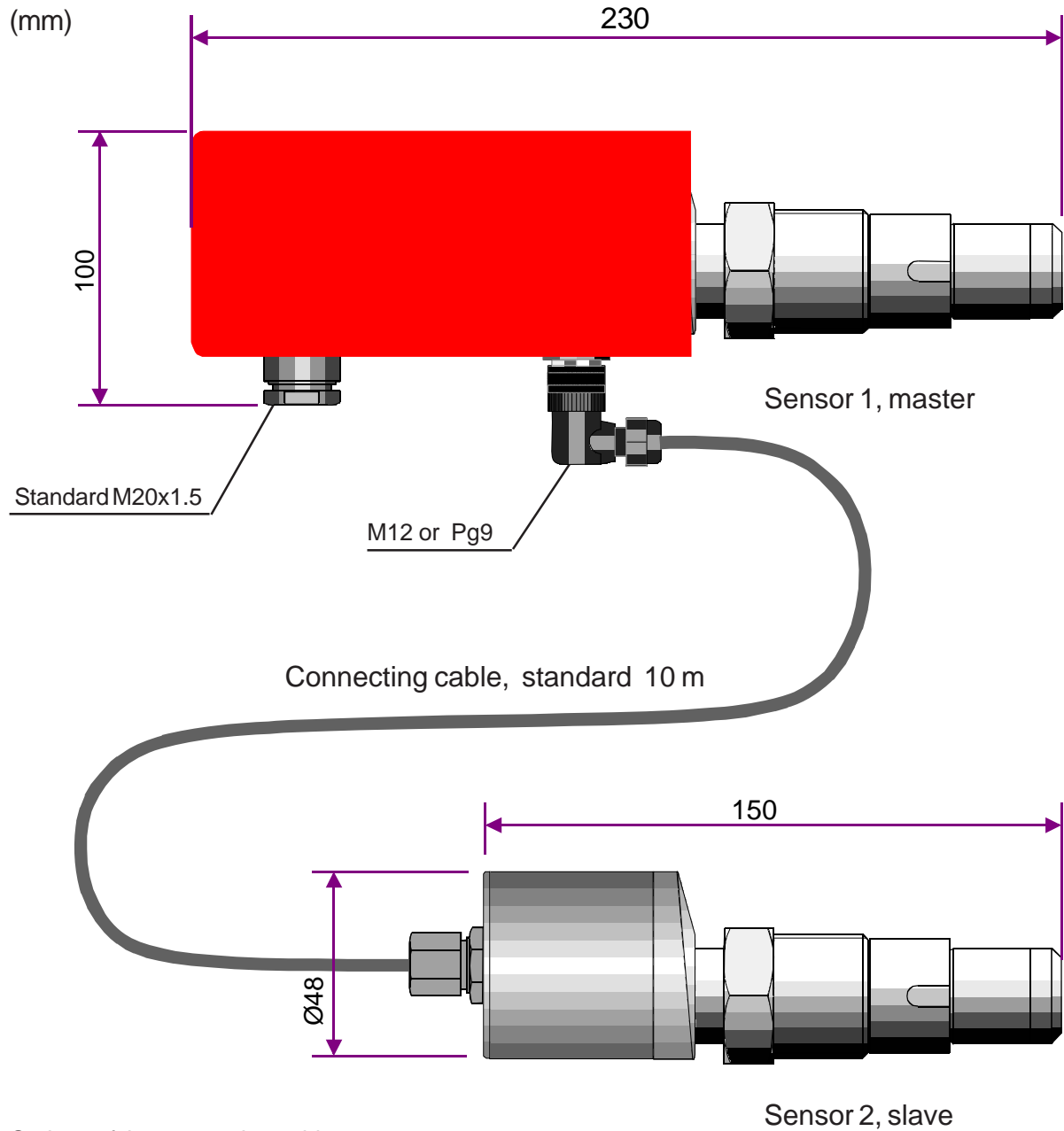

Options of the connecting cable:

a) M12 connector is situated at the end of sensor 1 and the end of sensor 2 is fixed. The material of the cable is PUR.

b) Cable is firmly connected to both sensors. The material of the cable is PVC. Cable glands are AISI316.

Process couplings, G1 thread

Transmitter's process sealing G1 thread

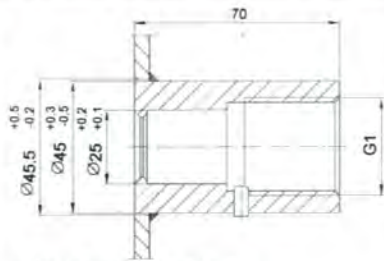

Standard coupling

Material: AISI316 L, Titanium or Hastelloy C

Special couplings:

- G1 hygienic coupling, M548101
- G1/2A/G1 coupling, M546190
- G1/2A/G1 coupling with venting, M860280
- G1/2A/ G1 couplings with bracket:
 - G1/2A male, M546195
 - G1/2 female, M550393

Three different options are available for the transmitter's process sealing

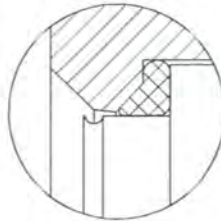

AISI316L diaphragm,
Viton O-ring
(code 1)

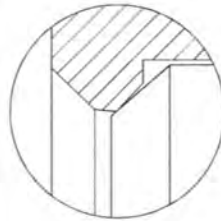

AISI316L diaphragm,
PTFE O-ring
(code 2)

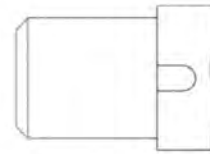
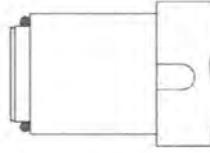

AISI316L, CoNi-, Duplex,
Hastelloy C276, Titanium
or Tantalum diaphragm,
metal/metal taper sealing
(diaphragm on sealing
face)
(code 4)

PASVE® mounting & service valve

All PASVE types are also available with pneumatic actuator, flushing and limit switches.

PASVE GF (NF) (Flange type)

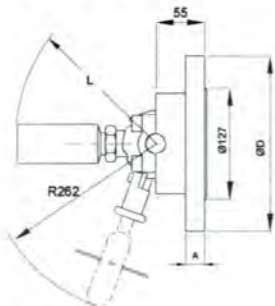

GP (NP) (Welded on pipe)

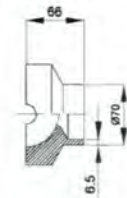

GC (NC) (Welded on container)

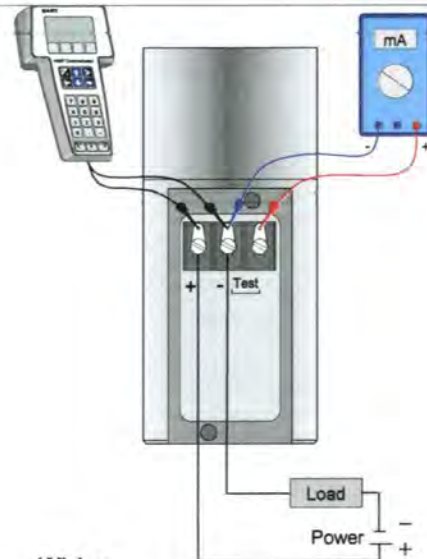
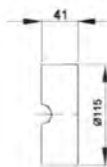

Wiring

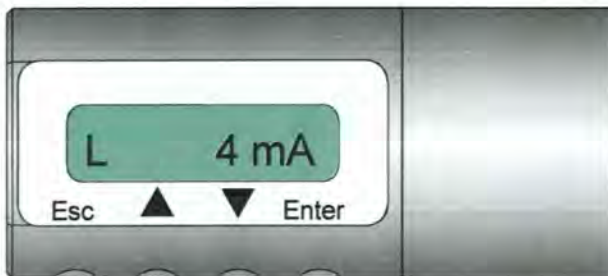

Keyboard :

- Esc = Press **Esc** move back towards the top of the main menu.
- ▲ = Use the **UP** arrow key to move up on the current menu level or to increase the selected parameter value.
- ▼ = Use the **DOWN** arrow key to move down on the current menu level or to decrease the selected parameter value.
- Enter = Press **ENTER** to move to a lower level in a menu or to accept a command or parameter value.

Process temperature limits, code H

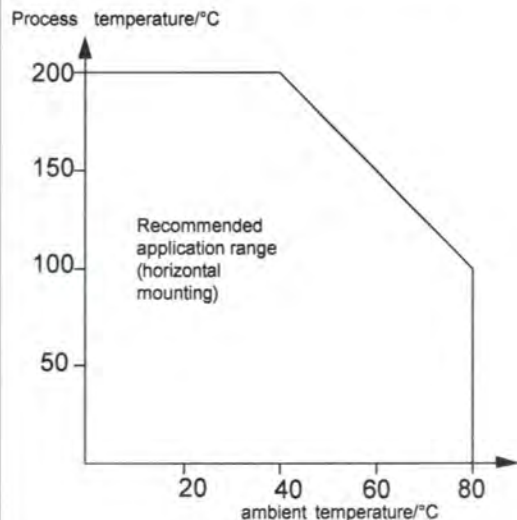

Dimensional drawings (dimensions in mm)

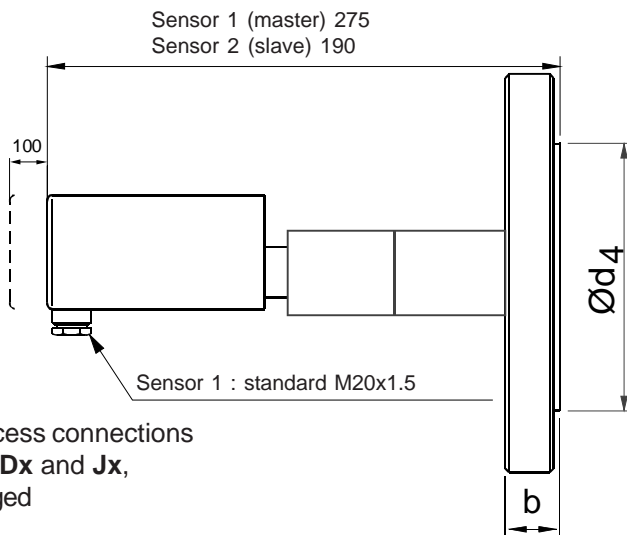
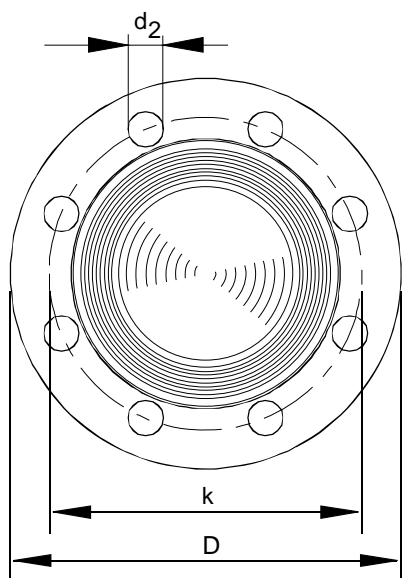

Process connections

Ax, Dx and Jx,
flanged

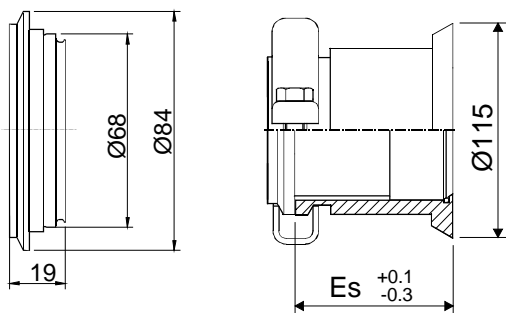

Process connection **UA,**
- Tuchenhagen DN50/40
(Varivent®)

Process connection **SA,**
- Sandvik-clamp

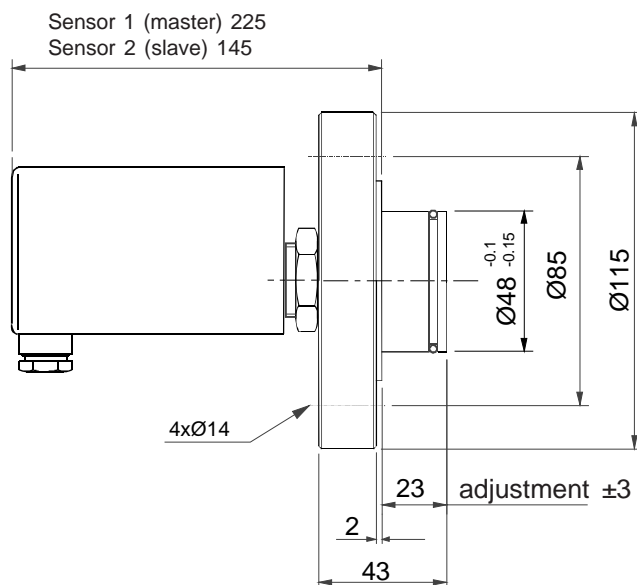

Process connection **DA,** DN25 PN40 flange with extension, process temperature max. +125°C

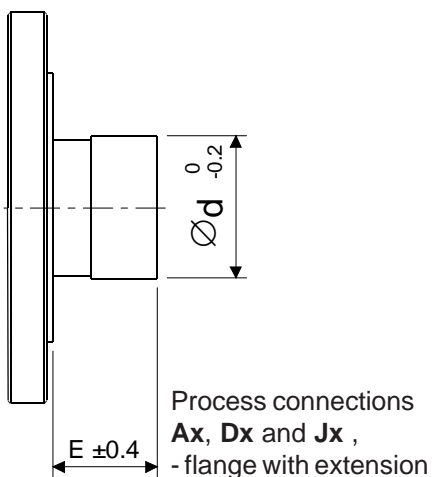

Code	E $\begin{matrix} +0.4 \\ -0.4 \end{matrix}$	Es $\begin{matrix} +0.3 \\ -0.2 \end{matrix}$
0	0	-
1	23	-
2	51	54,5
4	102	105
6	152	156

FLANGE SIZE	Flange dimens.			Holes			Extens.
	b	D	Ød ₄	pcs	d ₂	k	Ød -0.2
ISO DN25 PN40	18	115	68	4	14	85	48
ISO DN50 PN40	20	165	102	4	18	125	51
ISO DN80 PN40	24	200	138	8	18	160	73
ISO DN100 PN40	24	235	162	8	22	190	73
ANSI 1" 150 lbs	15	108	51	4	16	79.4	-
ANSI 1" 300 lbs	18	124	51	4	20	88.9	-
ANSI 2" 150 lbs	23	152	92	4	20	120.6	51
ANSI 2" 300 lbs	25	165	92	8	20	127	51
ANSI 3" 150 lbs	26	191	127	4	20	152.4	73
ANSI 3" 300 lbs	31	210	127	8	23	168.3	73
ANSI 4" 150 lbs	26	229	157	8	20	190.5	73
ANSI 4" 300 lbs	34	254	157	8	23	200	73
JIS 10K-50	16	155	96	4	19	120	51
JIS 40K-50	26	165	105	8	19	130	51
JIS 10K-80	18	185	126	8	19	150	73
JIS 40K-80	32	210	140	8	23	170	73
JIS 10K-100	18	210	151	8	19	175	73
JIS 40K-100	36	250	165	8	25	205	73

Dimensional drawings (dimensions in mm)

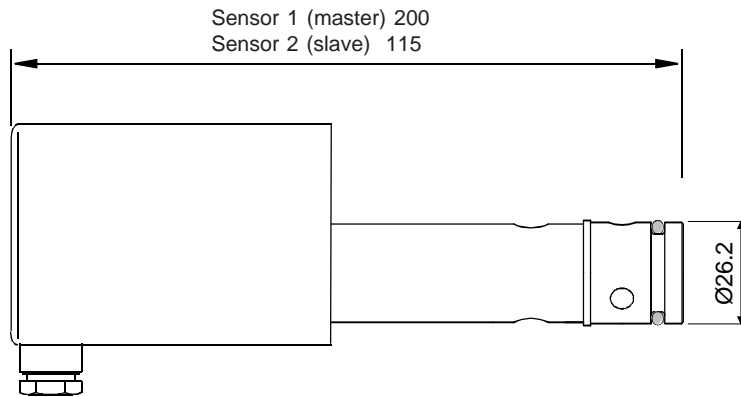

Process connection **PA**
- PMC 1"

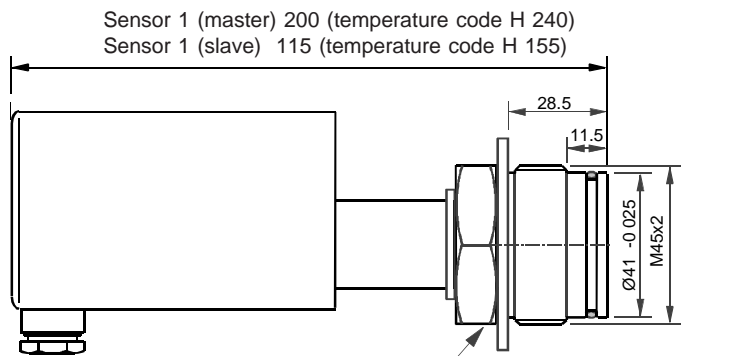

Process connection **BA**
- M45x2

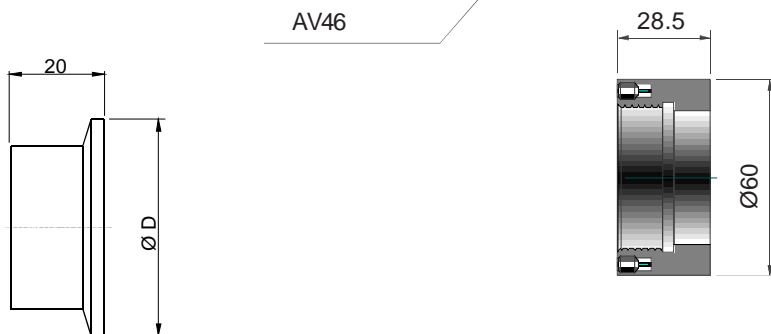

Coupling M45x2
with adjustment,
order code
M1050459

Process connections **TA** , **TB** and **TC**
- Tri-clamp DN38 ... 63,5

DN	ØD
38	50.5
51	64
63.5	77.5

Selection Chart

Adjustability	Span, min	Span, max.	Measuring range
VDU3	1.4kPa (14 mbar)	35 kPa (350 mbar)	-35...+35 kPa (-350...350 mbar)
VDU4	4kPa (40 mbar)	100 kPa (1000 mbar)	-100...+100 kPa (-1000...1000 mbar)
VDU5	26.5 kPa (265 mbar)	500 kPa (5000 mbar)	-100...+500 kPa (-1000...5000 mbar)
VDU6	0.145 MPa (1.45 bar)	3 MPa (30 bar)	-0.1...+3 MPa (-1...30 bar)

Output	S	D
	4-20mA DC/HART®	4-20mA DC/HART® and with galvanic isolation 4-20mA

Process connections			
DA	DN25 PN40 ISO 2084-1974	AA	ANSI 1" 150 lbs ANSI B16-5
DB	DN50 PN40 ISO 2084-1974	AB	ANSI 1" 300 lbs ANSI B16-5
DC	DN80 PN40 ISO 2084-1974	AC	ANSI 2" 150 lbs ANSI B16-5
DD	DN100 PN40 ISO 2084-1974	AD	ANSI 2" 300 lbs ANSI B16-5
JA	JIS 10K 50 JIS B 2220	AE	ANSI 3" 150 lbs ANSI B16-5
JB	JIS 40K 50 JIS B 2220	AF	ANSI 3" 300 lbs ANSI B16-5
JC	JIS 10K 80 JIS B 2220	AG	ANSI 4" 150 lbs ANSI B16-5
JD	JIS 40K 80 JIS B 2220	AH	ANSI 4" 300 lbs ANSI B16-5
JE	JIS 10K 100 JIS B 2220		
JF	JIS 40K 100 JIS B 2220		

Extension length (mm)	(Flanged conn.)	(Sandvik conn.)	
0	0	-	(not proc.conn. SA)
1	23	-	(only proc.conn. DA1, DN25 PN40, max. +125 °C)
2	51	54.5	(not proc.conn. Tx, UA, PA, DA, G1, G2 and G4)
4	102	105	(not proc.conn. Tx, UA, PA, DA, G1, G2 and G4)
6	152	156	(not proc.conn. Tx, UA, PA, DA, G1, G2 and G4)

Wetted materials		Diaphragm		Extension or other wetted parts	
Code	Material	Code	Material	Code	Material
1	Nickel (x) (***)	5	Tantalum (*) (***)	2	AISI316L
2	AISI316L	6	Titanium (xx) (***)	3	Hast.C 276
3	Hast.C 276 (*) (***)	8	Duplex (*) (***)	8	Duplex

Filling oil	S	G	A
	Silicone oil	Inert oil	Food industry oil (Neobee M20)

Housing type, master	
N	Housing with junction box/terminal strip, display, inlet M20x1,5

Explosion proof	
0	No explosion proof classification

Process temperature	N	H
	-30 ... +125 °C	0 ... +200 °C (*) (***)
	+20 ... +70 °C (only process connections BA and DA)	

Cable between sensors	
1	PUR cable with M12 connector
2	PVC cable with AISI316/ PG9 inlet, fixed factory mounted



Process couplings		Material	
0	Will be ordered separately	2	AISI316L
E	Hygienic couplings	3	Hast.C276
G	Standard couplings	6	Titanium
		8	Duplex

Special sizes of electrical inlets (Standard M20x1.5)		
N	1/2 NPT	P PLUG connector, DIN43650
G	Pg13.5	

Documentation	
Calibration certificate	AE English
Installation and Operating Instructions	IE English IF Finnish

Material certificates	
0	No material certificate
MC1	Raw material certificate without appendixes, in accordance with SFS-EN 10204-2.1 (DIN 50049-2.1) standard
MC2	Raw material certificate for wetted parts, in accordance with SFS-EN 10204-2.2 (DIN 50049-2.2) standard
MC3	Raw material certificate for wetted parts, in accordance with SFS-EN 10204-3.1 B (DIN 50049-3.1 B) standard

We reserve the right for technical modifications without prior notice.

HART is a registered trademark of HART Communication Foundation.
Pasve is a trademark of Satron Instruments Inc.
Hastelloy is the registered trademark of Haynes International.
Teflon is the registered trademark of E.I. du Pont de Nemours & Co.
Viton is the registered trademark of DuPont Down Elastomer.
Varivent is a registered trademark of GEA Tuchenhagen.

(*) = not proc.conn. G1 and G2
(**) = not for range 3
(***) = not for range 3 with process connection code G4
(x) = only with flange
(xx) = only with flange and G4