

USER'S GUIDE



Vaisala HUMICAP[®] Humidity and Temperature Probe HMP155



PUBLISHED BY

Vaisala Oyj
P.O. Box 26
FIN-00421 Helsinki
Finland

Phone (int.): +358 9 8949 1
Fax: +358 9 8949 2227

Visit our Internet pages at <http://www.vaisala.com/>

© Vaisala 2008

No part of this manual may be reproduced in any form or by any means, electronic or mechanical (including photocopying), nor may its contents be communicated to a third party without prior written permission of the copyright holder.

The contents are subject to change without prior notice.

Please observe that this manual does not create any legally binding obligations for Vaisala towards the customer or end user. All legally binding commitments and agreements are included exclusively in the applicable supply contract or Conditions of Sale.

Table of Contents

CHAPTER 1	
GENERAL INFORMATION	5
About This Manual	5
Contents of This Manual	5
Version Information	6
Related Manuals	6
General Safety Considerations	6
Feedback	7
Product Related Safety Precautions	7
Regulatory Compliances	7
Electromagnetic Compatibility	7
Recycling	8
Trademarks	8
License Agreement	8
Warranty	9
CHAPTER 2	
PRODUCT OVERVIEW	11
Introduction to HMP155	11
Basic Features and Options	12
Structure of the HMP155	13
Additional Temperature Probe Option	14
Warmed Probe Option	15
CHAPTER 3	
INSTALLATION	17
Installation in Radiation Shields	17
Installation in DTR13	18
Installation in DTR503	19
Installation in Stevenson Screen	20
8-Pin Connector	21
Temporary RS-485 Connection Option	22
CHAPTER 4	
OPERATION	23
Getting Started	23
RS-485 Interface	23
Serial Line Communication	24
Installing the Driver for the USB Cable	25
Terminal Program Settings	26
List of Serial Commands	29
Getting Measurement Message from Serial Line	31
R	31

S	31
SEND [ADDR]	31
SDELAY	32
Formatting Serial Line Message	32
Changing Quantities and Units.....	32
FORM.....	32
UNIT [M/N]	34
OVERICE [ON/OFF].....	34
Pressure Compensation Setting.....	35
Time.....	36
TIME [HH MM SS].....	36
Serial Settings	36
SERI [BAUD][PARITY][DATA][STOP]	36
SMODE	37
INTV	38
Data Filtering	38
FILT [0.1...1]	38
?.....	39
HELP	40
ERRS.....	41
VERS.....	41
Resetting Transmitter Using Serial Line.....	41
RESET.....	41
Formatting Analog Output.....	42
Analog Output Settings	42
AMODE	42
ASEL [CH1 CH2].....	43
ATEST	43
AERR.....	44
ADDR	45
OPEN	45
CLOSE	45
Sensor Functions	46
Chemical Purge (Optional)	46
Automatic Chemical Purge (Interval Purge).....	47
Manual Chemical Purge.....	47
Chemical Purge in Power Up.....	47
Starting and Configuring Chemical Purge.....	47
PUR.....	47
Sensor Heating.....	48
Setting Humidity Sensor Heating	49
XHEAT	49

CHAPTER 5

MAINTENANCE.....	51
Periodic Maintenance.....	51
Cleaning	51
Changing the Probe Filter	51
Changing the Sensor.....	52
Error States	54
Technical Support	55
Return Instructions	55
Vaisala Service Centers	56

CHAPTER 6	
CALIBRATION AND ADJUSTMENT	57
Push-Button Calibration	59
Two-Point Humidity and Temperature Adjustment	59
One-Point Humidity and Temperature Adjustment	61
Passive Output Version Push-Button Calibration	62
Serial Line Calibration	63
Two-Point Humidity Adjustment	63
Two-Point Temperature Adjustment	64
Relative Humidity Adjustment after Sensor Change.....	65
FCRH	65
One-Point Humidity and Temperature Adjustment	65
User Adjustment Commands	66
L	66
LI	66
Feeding Adjustment Information	67
CTEXT.....	67
CDATE	67
Analog Output Adjustment	67
ACAL [0/1].....	68
MI70 Check and Adjustment	68
 CHAPTER 7	
TECHNICAL DATA	71
Performance	71
Relative Humidity	71
Temperature.....	72
Operating Environment	72
Calculated Variables	73
Accuracies of Calculated Variables	73
Accuracy of Dewpoint Temperature °C.....	73
Accuracy of Mixing Ratio g/kg (Ambient Pressure 1013 mbar)	73
Accuracy of Wet Bulb Temperature °C	74
Accuracy of Dewpoint Measurement	74
Inputs and Outputs	75
Mechanics	75
Options and Accessories	76
Dimensions in mm (inches)	77
HMP155 Probe.....	77
Additional Temperature Probe	77
 APPENDIX A	
CALCULATION FORMULAS	79

List of Figures

Figure 1	HMP155 Probe.....	13
Figure 2	HMP155 with Additional T-probe	14

Figure 3	HMP155 with T-probe Installed in DTR13.....	18
Figure 4	HMP155 Installed in DTR503.....	19
Figure 5	HMP155 with T-Probe Installed in Stevenson Screen.....	20
Figure 6	Wiring of HMP155 8-Pin Connector.....	21
Figure 7	Pins Connected to Pt100 (passive output version).....	22
Figure 8	Starting HyperTerminal Connection.....	26
Figure 9	Connecting to HyperTerminal.....	27
Figure 10	HyperTerminal Serial Port Settings.....	28
Figure 11	Decrease of Sensor Gain.....	46
Figure 12	Changing the Sensor.....	53
Figure 13	HMP155 Adjustment Buttons.....	58
Figure 14	Accuracy over Temperature Range: Voltage and RS-485.....	72
Figure 15	Accuracy of Dewpoint Measurement.....	74
Figure 16	Probe Dimensions.....	77
Figure 17	Additional Temperature Probe Dimensions.....	77

List of Tables

Table 1	Manual Revisions.....	6
Table 2	Related Manuals.....	6
Table 3	Quantities Measured by HMP155.....	11
Table 4	Calculated Quantities Measured by HMP155.....	12
Table 5	Default Serial Communication Settings for the User Port.....	25
Table 6	Measurement Commands.....	29
Table 7	Formatting Commands.....	29
Table 8	Chemical Purge Commands (Optional).....	29
Table 9	Calibration and Adjustment Commands.....	29
Table 10	Setting and Testing the Analog Outputs.....	30
Table 11	Other Commands.....	30
Table 12	FORM Command Modifiers.....	33
Table 13	Selection of Output Modes.....	37
Table 14	Error Messages.....	54
Table 15	Calculated Variables.....	73
Table 16	Options and Accessories.....	76

CHAPTER 1

GENERAL INFORMATION

This chapter provides general notes for the manual and the product.

About This Manual

This manual provides information for installing, operating, and maintaining Vaisala HUMICAP[®] Humidity and Temperature Probe HMP155.

Contents of This Manual

This manual consists of the following chapters:

- Chapter 1, General Information, provides general notes for the manual and the Humidity and Temperature Probe HMP155.
- Chapter 2, Product Overview, introduces the features, advantages, and the product nomenclature of the Humidity and Temperature Probe HMP155.
- Chapter 3, Installation, provides you with information that is intended to help you install the Humidity and Temperature Probe HMP155.
- Chapter 4, Operation, contains information that is needed to operate the Humidity and Temperature Probe HMP155.
- Chapter 5, Maintenance, contains information that is needed in basic maintenance of the Humidity and Temperature Probe HMP155.
- Chapter 6, Calibration and Adjustment, provides information and instructions concerning calibration and adjustment of the Humidity and Temperature Probe HMP155.

- Chapter 7, Technical Data, provides the technical data of the Humidity and Temperature Probe HMP155.
- Appendix A, Calculation Formulas, presents the equations used in the Humidity and Temperature Probe HMP155 to calculate values of dewpoint, mixing ratio, absolute humidity and enthalpy in normal pressure.

Version Information

Table 1 Manual Revisions

Manual Code	Description
M210912EN-A	June 2008 - First release.

Related Manuals

Table 2 Related Manuals

Manual Code	Manual Name
M210913EN-A	Vaisala HUMICAP [®] Humidity and Temperature Probe HMP155 Quick Reference Guide

General Safety Considerations

Throughout the manual, important safety considerations are highlighted as follows:

WARNING

Warning alerts you to a serious hazard. If you do not read and follow instructions very carefully at this point, there is a risk of injury or even death.

CAUTION

Caution warns you of a potential hazard. If you do not read and follow instructions carefully at this point, the product could be damaged or important data could be lost.

NOTE

Note highlights important information on using the product.

Feedback

Vaisala Customer Documentation Team welcomes your comments and suggestions on the quality and usefulness of this publication. If you find errors or have other suggestions for improvement, please indicate the chapter, section, and page number. You can send comments to us by e-mail: manuals@vaisala.com

Product Related Safety Precautions

Vaisala HUMICAP[®] Humidity and Temperature Probe HMP155 delivered to you has been tested for safety and approved as shipped from the factory. Note the following precautions:

WARNING

Ground the product, and verify outdoor installation grounding periodically to minimize shock hazard.

CAUTION

Do not modify the unit. Improper modification can damage the product or lead to malfunction.

Regulatory Compliances

Vaisala HUMICAP[®] Humidity and Temperature Probe HMP155 complies with the following performance and environmental test standards:

Electromagnetic Compatibility

Complies with EMC standard EN 61326-1, Electrical equipment for measurement, control and laboratory use - EMC requirements for use in industrial locations.

Recycling



Recycle all applicable material.



Dispose of batteries and the unit according to statutory regulations.
Do not dispose of with regular household refuse.

Trademarks

HUMICAP[®] is a registered trademark of Vaisala. Microsoft[®], Windows[®], Windows[®] NT, Windows[®] 2000, Windows[®] XP, and Windows[®] Vista are registered trademarks of Microsoft Corporation in the United States and/or other countries.

License Agreement

All rights to any software are held by Vaisala or third parties. The customer is allowed to use the software only to the extent that is provided by the applicable supply contract or Software License Agreement.

Warranty

Vaisala hereby represents and warrants all Products manufactured by Vaisala and sold hereunder to be free from defects in workmanship or material during a period of twelve (12) months from the date of delivery save for products for which a special warranty is given. If any Product proves however to be defective in workmanship or material within the period herein provided Vaisala undertakes to the exclusion of any other remedy to repair or at its own option replace the defective Product or part thereof free of charge and otherwise on the same conditions as for the original Product or part without extension to original warranty time. Defective parts replaced in accordance with this clause shall be placed at the disposal of Vaisala.

Vaisala also warrants the quality of all repair and service works performed by its employees to products sold by it. In case the repair or service works should appear inadequate or faulty and should this cause malfunction or nonfunction of the product to which the service was performed Vaisala shall at its free option either repair or have repaired or replace the product in question. The working hours used by employees of Vaisala for such repair or replacement shall be free of charge to the client. This service warranty shall be valid for a period of six (6) months from the date the service measures were completed.

This warranty is however subject to following conditions:

- a) A substantiated written claim as to any alleged defects shall have been received by Vaisala within thirty (30) days after the defect or fault became known or occurred, and
- b) The allegedly defective Product or part shall, should Vaisala so require, be sent to the works of Vaisala or to such other place as Vaisala may indicate in writing, freight and insurance prepaid and properly packed and labelled, unless Vaisala agrees to inspect and repair the Product or replace it on site.

This warranty does not however apply when the defect has been caused through

- a) normal wear and tear or accident;
- b) misuse or other unsuitable or unauthorized use of the Product or negligence or error in storing, maintaining or in handling the Product or any equipment thereof;
- c) wrong installation or assembly or failure to service the Product or otherwise follow Vaisala's service instructions including any repairs or installation or assembly or service made by unauthorized personnel not approved by Vaisala or replacements with parts not manufactured or supplied by Vaisala;
- d) modifications or changes of the Product as well as any adding to it without Vaisala's prior authorization;
- e) other factors depending on the Customer or a third party.

Notwithstanding the aforesaid Vaisala's liability under this clause shall not apply to any defects arising out of materials, designs or instructions provided by the Customer.

This warranty is expressly in lieu of and excludes all other conditions, warranties and liabilities, express or implied, whether under law, statute or otherwise, including without limitation any implied warranties of merchantability or fitness for a particular purpose and all other obligations and liabilities of Vaisala or its representatives with respect to any defect or deficiency applicable to or resulting directly or indirectly from the Products supplied hereunder, which obligations and liabilities are hereby expressly cancelled and waived. Vaisala's liability shall under no circumstances exceed the invoice price of any Product for which a warranty claim is made, nor shall Vaisala in any circumstances be liable for lost profits or other consequential loss whether direct or indirect or for special damages.

This page intentionally left blank.

CHAPTER 2

PRODUCT OVERVIEW

This chapter introduces the features, advantages, and the product nomenclature of the Vaisala HUMICAP[®] Humidity and Temperature Probe HMP155.

Introduction to HMP155

The HMP155 probe provides reliable humidity and temperature measurement in a wide range of applications. Humidity measurement is based on the capacitive thin film polymer sensor HUMICAP[®]180R. Temperature measurement is based on resistive platinum sensors (Pt100). Both the humidity and temperature sensors are located at the tip of the probe, protected by a sintered Teflon filter.

The HMP155 comes in active and passive output models where the relative humidity voltage output is similar, but the temperature output is either active or passive (resistive). Active output version has either two analog outputs or an RS-485 digital output. Passive output version has 4-wire temperature measurement and an analog voltage output for relative humidity measurement.

The quantities measured and calculated by HMP155 are presented in Table 3 below. The quantities available as an option are presented in Table 4 on page 12.

Table 3 Quantities Measured by HMP155

Quantity	Abbreviation	Metric Unit	Non Metric Unit
Relative humidity (RH)	RH	%RH	%RH
Temperature (T)	T	°C	°F
Additional T-probe temperature (T _a)	T _a	°C	°F

Table 4 **Calculated Quantities Measured by HMP155**

Quantity	Abbreviation	Metric Unit	Non Metric Unit
Dewpoint / Frostpoint Temperature ($T_{d/f}$)	TDF	°C	°F
Dewpoint Temperature (T_d)	TD	°C	°F
Mixing ratio (x)	X	g/kg	gr/lb
Wetbulb temperature (T_w)	TW	°C	°F

Basic Features and Options

- Can be used to replace HMP45A/D, also in radiation shields
- Improved performance with the HUMICAP[®]180R sensor and alternatively the HUMICAP[®]180RC sensor. Also available with the HUMICAP[®]180 sensor.
- Warmed humidity probe for improved performance in constant high humidity (active output version)
- Different voltage ranges possible: 0...1 V, 0...5 V, 0...10 V (active and passive output versions)
- Different T-output scales possible: -40...+60°C, -20...+40°C, -80...+60°C (active output version)
- Chemical purge option for applications where interfering chemicals in the measuring environment pose a risk (active output version)
- Additional temperature probe (T-probe) with fast response (active output version)
- USB connectivity for service connections via the optional USB-M12 cable (active and passive output versions)
- Installation kits for T-probe into DTR13 and DTR502 radiation shields.
- Installation kit for Stevenson screen (active and passive output version, both with and without additional T-probe)
- MI70 connectivity for field checking and calibration (active and passive output versions)

Structure of the HMP155

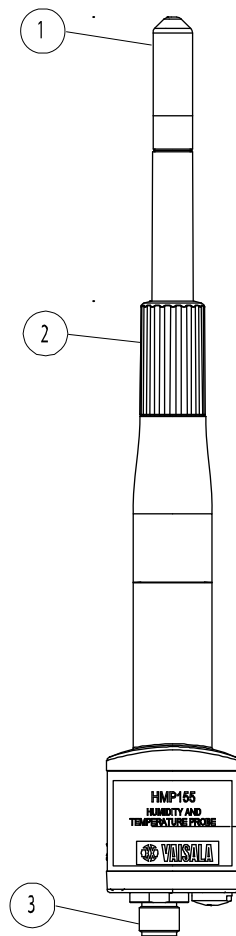

0801-070

Figure 1 HMP155 Probe

The numbers refer to Figure 1 above.

- 1 = Filter
- 2 = Protective cover
- 3 = 8-Pin connector (M12)



0801-080

Figure 2 HMP155 with Additional T-probe

Additional Temperature Probe Option

The active output version of HMP155 can be ordered with an additional temperature probe option, see Figure 2 above. When the additional T-probe is in use, the relative humidity value is calculated based on the T_d (dewpoint) value obtained from the humidity probe and the T_a value obtained from the T-probe.

When installing HMP155 with T-probe, it is important to make sure that the humidity probe and the T-probe are installed in the same conditions in order to get accurate readings. Even a slight difference in temperature conditions between the T-probe and the humidity probe will result in false RH readings. The two probes need to be installed so that the humidity probe does not heat the T-probe, but is close enough for the probes to share the same environment conditions. When the RH reading is required, always install the T-probe in the place where you need the reading from.

Warmed Probe Option

In changing temperature conditions with high humidity, the probe temperature can lag behind the temperature of the surrounding air and this can cause a risk of condensation on the sensor. A wet probe cannot observe the actual humidity in the ambient air. If the condensed water is contaminated, the life span of the probe may shorten and the calibration may change.

The HMP155 warmed probe is heated continuously so that its temperature is always higher than that of the environment. This prevents condensation on the probe.

This page intentionally left blank.

CHAPTER 3

INSTALLATION

This chapter provides you with information that is intended to help you install the product.

Installation in Radiation Shields

In order to reach the maximum performance level of the HMP155 probe, Vaisala recommends installing the HMP155 in a radiation shield, for example in DTR503, in DTR13 or in a Stevenson screen. See Figure 3 on page 18, Figure 4 on page 19 and Figure 5 on page 20.

Installation in DTR13

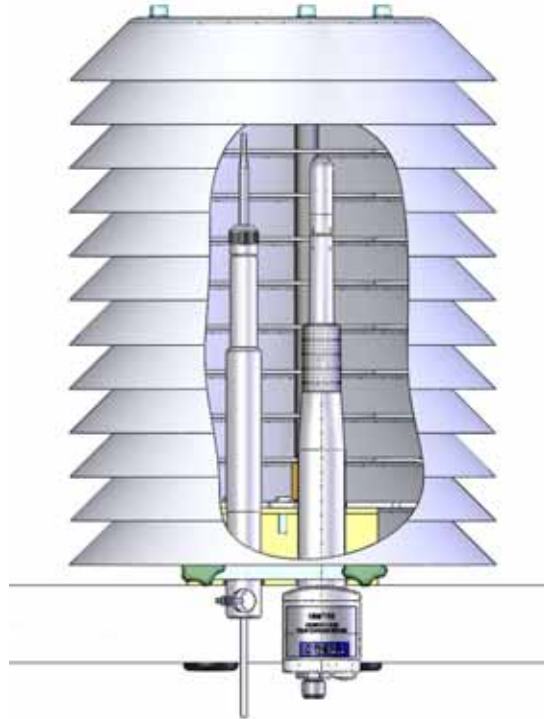

0801-071

Figure 3 HMP155 with T-probe Installed in DTR13

Installation in DTR503

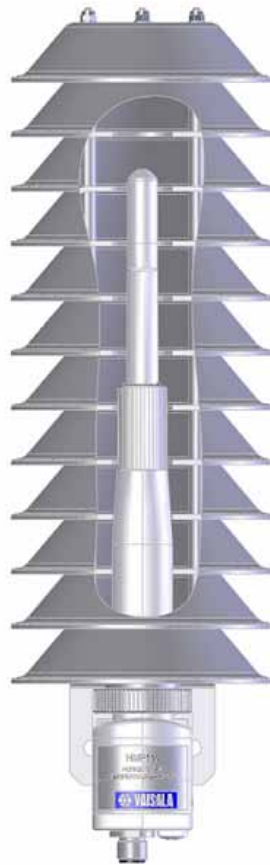

0801-072

Figure 4 HMP155 Installed in DTR503

Installation in Stevenson Screen



0805-008

Figure 5 HMP155 with T-Probe Installed in Stevenson Screen

8-Pin Connector

Both the passive and active versions of HMP155 come with an 8-pin connector on the bottom of the probe.

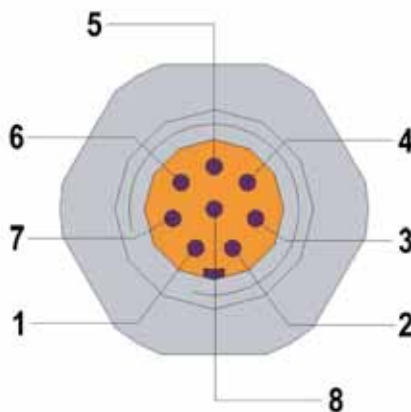

0507-044

Figure 6 Wiring of HMP155 8-Pin Connector

The pins of the connector for HMP155 passive output version in Figure 6 are (open end wire colors in brackets):

- 1 = PT100 (white)
- 2 = $RH_{OUT} 0...1$ V (brown)/RS-485-B
- 3 = PT100 (green)
- 4 = PT100 (yellow)
- 5 = PT100 (grey)
- 6 = A_{GND} (pink)/RS-485-A
- 7 = V_{CC} (blue)
- 8 = GND (red)
- = SHIELD (black)

The pins of the connector for HMP155 active output version in Figure 6 are (open end wire colors in brackets):

- 1 = V_{OUT1} (white)
- 2 = RS-485-B (brown)
- 3 = A_{GND} (green)
- 4 = V_{OUT2} (yellow)
- 5 = -
- 6 = RS-485-A (pink)
- 7 = V_{CC} (blue)
- 8 = GND (red)
- = SHIELD (black)

The last entry in the list of pins, SHIELD, is not a pin but one of the conductors in the connection cable. The SHIELD wire color is black.

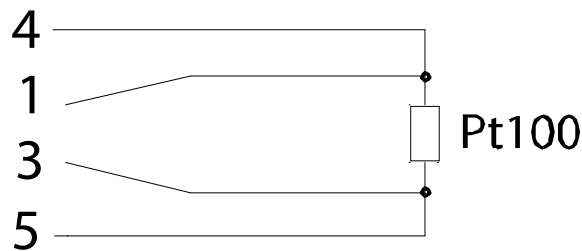

0802-039

Figure 7 Pins Connected to Pt100 (passive output version)

Temporary RS-485 Connection Option

It is possible to have a temporary RS-485 connection also in the passive output version by resetting the probe, while simultaneously holding down the **ADJ** button, see Figure 13 on page 58. After the probe has restarted, pins 2 and 6 then have the RS-485 signal. For the order of the pins, see Figure 6 on page 21. The default signals are returned to the pins after the next reset.

CHAPTER 4

OPERATION

This chapter contains information that is needed to operate this product.

Getting Started

After the Vaisala HUMICAP[®] Humidity and Temperature Probe HMP155 has been connected to a power supply, the serial line and the analog outputs are operational.

RS-485 Interface

HMP155 supports a two-wire RS-485 communication. The RS-485 interface is non-isolated and offers a maximum communications rate of 19200 bits/s. There is no internal termination for the RS-485 on the HMP155. If any termination is needed, the bus should be terminated at both ends. The recommended termination is R termination with 120 Ohm resistors.

Typically the termination resistors are only needed when the fastest communications rate (19200 bit/s) is used for longer distances. If the resistors are used, the possible increase in current consumption should be taken into account.

Serial Line Communication

Connect the probe to a PC, for example, by using a USB cable (optional accessory item: 221040). Connect the USB cable to the 8-pin connector on the bottom of the probe. Before you can use the USB cable, you must install the provided USB driver on your PC, see Installing the Driver for the USB Cable on page 25.

NOTE

When using the USB-cable, no separate power unit is needed. The probe is powered through the USB port.

For permanent interfacing to host system, use the serial line. You can change the serial settings and operate in RUN, STOP and POLL modes.

HMP155 does not echo typed characters back to the terminal screen. To see the commands you type, you need to enable the "local echo" - setting in your terminal program.

A new command cannot be received while the instrument is sending data out. Wait until the instrument has completed its response before entering the next command.

NOTE

In the RUN mode, the instrument may send the measurement data message right as you are typing the **S** command to stop the sending. Therefore, you may need to repeat the **S** command. This must be noted especially when designing computer programs to access the HMP155. You can also use the **Esc** key on your keyboard to stop the sending.

Installing the Driver for the USB Cable

Before taking the USB cable into use, you must install the provided USB driver on your PC. When installing the driver, you must acknowledge any security prompts that may appear. The driver is compatible with Windows 2000, Windows XP, and Windows Vista.

1. Check that the USB cable is not connected. Disconnect the cable if you have already connected it.
2. Insert the media that came with the cable, or download the driver from www.vaisala.com.
3. Execute the USB driver installation program (setup.exe), and accept the installation defaults. The installation of the driver may take several minutes.
4. After the driver has been installed, connect the USB cable to a USB port on your PC. Windows will detect the new device, and use the driver automatically.
5. The installation has reserved a COM port for the cable. Verify the port number, and the status of the cable, using the **Vaisala USB Instrument Finder** program that has been installed in the Windows Start menu. The reserved ports are also visible in the **Ports** section of the Windows Device Manager.

Remember to use the correct port in the settings of your terminal program. Windows will recognize each individual cable as a different device, and reserve a new COM port.

There is no reason to uninstall the driver for normal use. However, if you wish to remove the driver files and all Vaisala USB cable devices, you can do so by uninstalling the entry for **Vaisala USB Instrument Driver** from the **Add or Remove Programs (Programs and Features** in Windows Vista) in the Windows Control Panel.

Table 5 Default Serial Communication Settings for the User Port

Parameter	Value
Bauds	4800
Parity	Even
Data bits	7
Stop bits	1
Flow control	None

After power-up the transmitter (in STOP-mode) outputs the software version and the command prompt.

```
HMP155 0.98  
>
```

In RUN mode a measurement output starts immediately after power-up.

In POLL mode, the transmitter does not output anything after power-up, see section on page 37.

Terminal Program Settings

The following instructions show a connection example with HyperTerminal program (included in the Microsoft Windows®).

Follow the instructions below to open a HyperTerminal program:

1. Start HyperTerminal. To get help for starting HyperTerminal, click **Start**, select **Help** to open Windows help, and search for "HyperTerminal".



0801-073

Figure 8 Starting HyperTerminal Connection

2. In **New Connection** window of the HyperTerminal, define a name for HMP155 serial connection, for example "HMP155". Click **OK**.

3. In **Connect using** pull down menu, select the PC communications port where the serial cable is connected. (If your computer has only one COM port, it is called "COM1"). Click **OK**.



0801-074

Figure 9 Connecting to HyperTerminal

4. In the **Properties** window, set the port settings to match the settings of your HMP155. For HMP155, **Flow control** must always be set to **None**. Finally click **OK** to start using the serial connection.

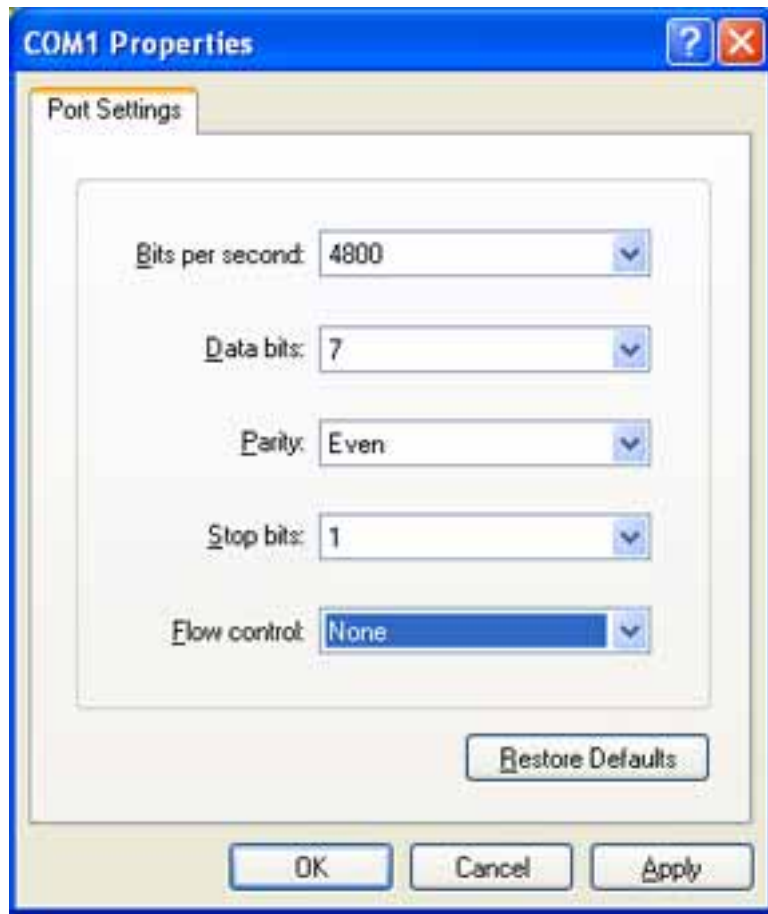

0801-075

Figure 10 HyperTerminal Serial Port Settings

5. In the HyperTerminal main window, select **File → Save** to save the serial port settings. To use the saved settings later, start HyperTerminal and in the **New Connection** window, click **Cancel** and select **File → Open**.

List of Serial Commands

Most of the commands listed below can only be used in active output version of HMP155. These commands are marked with an * in the description column to make them easier to tell apart. The **bold** text in the brackets is the default setting. To issue a command, type it on your computer and press the **Enter** key.

Table 6 Measurement Commands

Command	Description
R	Start the continuous outputting
S	Stop the continuous outputting
INTV [0 ... 255 S /MIN/H]	Set the continuous output interval (for RUN mode)
SEND [0 ... 99]	Output the reading once *
SMODE [STOP /RUN/POLL/SEND]	Set the serial interface mode *
SDELAY[0 ... 255]	View or set user port (RS-485) answer minimum delay *
SERI [baud p d s]	User Port settings (Default: 4800 E 7 1) baud: 300 ... 115200 *
ADDR [0 ... 99]	Set the transmitter address (for POLL mode) *
OPEN [0 ... 99]	Open a temporary connection to a POLL mode device *
CLOSE	Close the temporary connection (Back to POLL mode) *

Table 7 Formatting Commands

Command	Description
FORM	Set the output format of SEND and R commands *
OVERICE [ON/OFF]	Select the output for below freezing temperatures *
TIME [HH MM SS]	Set or display the time *
UNIT	Select the metric or non-metric output units *

Table 8 Chemical Purge Commands (Optional)

Command	Description
PUR	Set the automatic chemical purge *

Table 9 Calibration and Adjustment Commands

Command	Description
ACAL [0/1]	Analog output calibration *
CDATE	Set the calibration date

Command	Description
CRH	Relative humidity calibration
CT	Temperature calibration *
CTA	Additional temperature probe calibration *
FCRH	Relative humidity calibration after sensor change
CTEXT	Give the text to calibration information field
L	Displays user adjustment parameters
LI	Displays new values for the user adjustment parameters

Table 10 Setting and Testing the Analog Outputs

Command	Description
AMODE	View the analog output modes*
ASEL	Set or view analog output quantities and scaling *
AERR	Change the analog error output values
ATEST	Force the analog outputs to entered values*

Table 11 Other Commands

Command	Description
?	Output information about the device
??	Output information about the device in POLL mode *
ERRS	List present transmitter errors
FILT [0.1...1]	Set the result filtering
HELP	Lists the available commands
PRES [hPa]	Set the value for pressure compensations
RESET	Resets the probe.
VERS	Display the software version information
XHEAT	Sensor heating *
XPRES [bar]	Set the value for pressure compensations, temporarily

Getting Measurement Message from Serial Line

R

Enter the **R** command to start the continuous output of measurements. This command starts a temporary RUN mode. To change to permanent RUN mode, use the **SMODE** command.

Example:

```
>r  
RH= 33.0 %RH T= 22.1 'C  
>
```

If a value is too long to fit to the allocated space in the output, or if there is an error in outputting the quantity, the value is displayed with stars '*'.

The output format can be adjusted with the **FORM** command and the output interval can be changed with the **INTV** command.

S

Use the **S** command to end the RUN mode. After this command all other commands can be used. You can also press the **Esc** key on your keyboard or reset the transmitter to stop the outputting.

See **SMODE** command on page 37 to change the default (power up) operation mode.

SEND [ADDR]

Use the **SEND** command, where ADDR is the address of the transmitter, to output the reading once in STOP mode. The **SEND** command can also be used without the address. The output format depends on which parameters the transmitter can output.

Example without parameter:

```
>send  
RH= 24.9 %RH T= 22.1 'C  
>
```

SDELAY

To view or set the minimum answer delay for the user port (RS-485), use the **SDELAY** command. The value corresponds to milliseconds delay and is set between 1 ... 255. By default the value is set to 10.

where

1 = 4-8 ms
255 = 1024 ms

Example:

```
>sdelay 15  
Serial delay : 15  
>
```

Formatting Serial Line Message

Changing Quantities and Units

Use the **FORM** serial line command to change the format or select certain quantities for the output commands **SEND** and **R**. Use the **UNIT** serial line command to select metric or non-metric output units.

FORM

Use the serial line command **FORM** to change the format or select certain quantities for the output commands **SEND** and **R**.

FORM [x]

where

x = Formatter string

Formatter string consists of quantities and modifiers.

When entering the command, use the abbreviations of the quantities. For more information on quantities, see Table 3 and Table 4 on page 11.

The modifiers are presented in Table 12 on page 33.

Table 12 FORM Command Modifiers

Modifier	Description
quantity	Quantity name (for example RH, T or TDF)
x.y	Length modifier (number of digits and decimal places)
#t	Tabulator
#r	Carriage-return
#n	Line feed
""	String constant
#xxx	Special character with decimal code "xxx"
U5	Unit field and length
ADDR	Transmitter address with two characters [00...99]
ERR	Error flags for P, T, Ta, RH [0000 ... 1111], 0 = no error
STAT	Transmitter status in 7 character field, for example: N no heating h probe heating active, power H purge heating active, temperature S purge cooling active, temperature X sensor heating active, temperature
SNUM	Transmitter serial number
TIME	Time [hh:mm:ss]

Example:

```
>form "Temperature=" 5.2 t #r#n
OK
>send
Temperature=    24.23
>
```

```
>form "Twet=" 6.3 tw U3 #t "T=" t U3 #r#n
OK
>send
Twet=    11.290 'C          T=    24.231 'C
>
```

```
>form 5.1 rh #t t #t tdf #r#n
OK
>send
    15.6    24.2    -3.1
>
```

FORM / command returns the default output format. The default output format depends on the device configuration. **FORM** command returns the current output format of the transmitter. You can only give a maximum of 73 characters after the command on the command line.

```
>form /
OK
>send
RH= 23.8 %RH T= 19.4 'C
>
```

UNIT [M/N]

Use the **UNIT** command to select metric or non-metric output units.

UNIT [M/N]

where

M = Metric units

N = Non-metric units

Example:

```
>unit n
Units   : non metric
>
```

OVERICE [ON/OFF]

Use the **OVERICE** command to select the probe dewpoint output in below freezing temperatures. When overice is set to OFF and the temperature is below freezing, the probe outputs dewpoint readings. If overice is set to ON and the temperature is below freezing, the probe outputs a frostpoint reading.

```
overice off
Overice      :      OFF
```

Pressure Compensation Setting

Use the **PRES** serial line command to set ambient pressure value for fixed pressure compensation. If the value is changed frequently, use the **XPRES** serial line command. Its value is cleared to 0.0 at reset; if it is set to other than 0, it overrides the setting given with the **PRES** command.

NOTE

In normal pressure conditions, **PRES** command is not needed. But if mixing ratio is used in high altitudes, the pressure changes will increase the mixing ratio.

Use the serial line and do the following:

PRES [*a.aaaa*]

where

a.aaaa= Ambient pressure value (bar)

Example:

```
>pres
Pressure      : 1.013 bar ?
>
```

XPRES [*a.aaaa*]

where

a.aaaa =Ambient pressure value (bar)

Example:

```
>xpres
Pressure: 0.000 bar      ?
>
```

Time

To set or display the current time, use the **TIME** serial line command.

TIME [HH MM SS]

Example:

```
> time 12 00 00
Time           : 12:00:00
>
```

When you set the current time for the probe with the **TIME** command, the time will be displayed as long as the probe is turned on. The time setting will not be stored in any memory. At reset or when the probe is turned off, the time will go back to 00:00:00.

Serial Settings

SERI [BAUD][PARITY][DATA][STOP]

To set the communication settings, use the **SERI** serial line command.

SERI [BAUD][PARITY][DATA][STOP]

where

baud = Bit rate (300, 600, 1200, 2400, 4800, 9600, 19200)

parity = Parity (n = none, e = even, o = odd)

data = Data bits (7 or 8)

stop = Stop bits (1 or 2)

You need to reset the transmitter to activate the new communication settings set with **SERI** command.

The settings can be changed one parameter at a time or all parameters at once.

Example:

Changing all parameters

```
>seri 9600 e 7 1
Baud P D S      : 9600 E 7 1
>
```

Example:

Changing baud only

```
>seri 4800
Baud P D S      : 4800 E 7 1
>
```

SMODE

Use the **SMODE** command to set the user port to permanent STOP, RUN, POLL or SEND mode.

SMODE [xxxx]

where

xxxx= STOP, RUN, POLL or SEND

Example:

```
>smode
Serial mode      : STOP ? POLL
>
```

Table 13 Selection of Output Modes

Mode	Output	Available Commands
STOP	Only with the SEND command	All (default mode)
RUN	Automatic output	Only command S
POLL	Only with the SEND [addr] command	Use with RS-485 buses

Selected output mode will be activated after power outages.

INTV

Use the **INTV** command to set the outputting interval for the RUN mode. The default value for this command is 2 seconds.

INTV [xxx yyy]

where

xxx = Output interval (0...255) where 0 is the fastest possible output rate.

yyy = Unit (s, min or h)

Example:

```
>intv 1 min
Interval      : 1 min
>
```

Data Filtering

The commands introduced in this section are used for setting the filtering level, checking the probe configuration, listing available commands and possible error messages, and displaying the software information of the probe.

FILT [0.1...1]

Use the **FILT** [xxx] serial line command to set the filtering level. The default setting is 1. The output is calculated based on the following formula: [(new result * filt) + (old result * (1.0 - filt))].

FILT [xxx]

where

xxx = 0.1...1 where 1.0 = no filter and 0.1 = about 16 moving average

Example:

```
>filt
Filter       : 0.800 ?
>
```

?

Use the ? serial line command to check the current probe configuration. ?? command is similar but can also be used if the probe is in POLL mode.

Example:

```
>?
HMP155 1.00
Serial number : C1230001
Batch number  : B2350090
Module number : C4840248
Sensor number  : B4250001
Sensor model   : Humicap 180
Cal. date      : YYYYMMDD
Cal. info      : NONE
Time           : 00:01:06
Serial mode    :      STOP
Baud P D S    :      4800 E 7 1
Output interval:      2 S
Serial delay   :      0
Address        :      0
Pressure       :      1.013 bar
Filter         :      0.800
Ch0 output     : 0 ... 1 V
Ch1 output     : 0 ... 1 V
Ch0 error out  :      0.00 V
Ch1 error out  :      0.00 V
Ch0 RH lo     :      0.00 %RH
Ch0 RH hi     :     100.00 %RH
Ch1 T lo      :     -40.00 'C
Ch1 T hi      :      60.00 'C
>
```

HELP

Use the **HELP** command to list the available commands.

Example:

```
>help
?
??
ACAL ch0/ch1
ADDR 0...99
AERR err1 err2
AMODE ch1 ch2
ASEL quantity1 quantity2 low1 high1 low2 high2
ATEST value1 value2
CDATE 'cal.date'
CLOSE
CRH
CT
CTA
CTEXT 'cal.info'
ERRS
FCRH
FILT value
FORM 'format string'
HELP
INTV 0...255 s/min/h
L
LI
OPEN addr
OVERICE on/off
PRES bar
PUR on/off
R
RESET
S
SDELAY 0...255
SEND addr
SERI baud p d s
SMODE stop/run/poll
TIME hh:mm:ss
UNIT m/n
VERS
XHEAT on/off
XPRES bar
>
```

ERRS

Use the **ERRS** command to display probe error messages, see Table 14 on page 54.

Example:

```
>errs  
No errors  
>
```

VERS

Use the **VERS** command to display software version information.

Example:

```
>vers  
HMP155 1.01  
>
```

Resetting Transmitter Using Serial Line

RESET

Use the **RESET** command to reset the device. The user port switches to start-up output mode selected with **SMODE** command.

Example:

```
>reset  
  
HMP155 1.00  
>
```

Formatting Analog Output

In this section, the commands for formatting the analog output settings are introduced.

Analog Output Settings

The two analog outputs are set in the factory according to the order form. In case you want to change the settings, follow these instructions.

NOTE

The serial line commands **AMODE**, **ASEL** and **ATEST** cannot be used with the passive output version of HMP155.

AMODE

Use the serial line to select and scale the analog output quantities. Connect the probe to the PC and then open the terminal connection between your PC and the probe.

The probe needs to be in ADJUST mode for the **AMODE** command to work. To put the probe in ADJUST mode, hold down the **ADJ** button until a green LED lights up.

Check the analog output modes with the **AMODE** command.

Analog output modes are:

```
3 = 0...1 V
4 = 0...5 V
5 = 0...10 V
```

Example:

```
>amode 3 3
Ch0 : 0 ... 1V
Ch1 : 0 ... 1V
>
```

NOTE

If you scale the analog output quantities with **AMODE** command, you must continue by entering the **ACAL** command, see **ACAL** on page 68.

ASEL [CH1 CH2]

where

CH1 = Quantity of channel 1

CH2 = Quantity of channel 2

Select and scale the quantities for the analog outputs with the **ASEL** command. Note that the optional quantities can be selected only if they have been selected when ordering the device.

You can use **ASEL** command with parameters. There you enter all the quantities for all the outputs at once. **ASEL** command can also be used without parameters, like in the example below, in which case the transmitter will ask for each parameter separately. Always enter all the quantities for all outputs. For quantities and their abbreviations see Table 3 on page 11 and Table 4 on page 12.

Use the command **ASEL [CH1 CH2]** as shown in the example below when using a device with two analog outputs.

Example:

```
asel <cr>
Ch1 T lo : -40.00 'C ?
Ch1 T hi : 60.00 'C ?
Ch0 RH lo : 0.00 %RH ?
Ch0 RH hi : 100.00 %RH ?
```

AATEST

Use the serial line to test the operation of all the analog outputs. Use the **AATEST** command to force the analog outputs to entered values. The set values remain valid until you enter the **AATEST** command without parameters or reset the probe. Entering the **AATEST** command without parameters outputs the current value.

AATEST [V] [V]

where

V = Output value for channel 1 (V)

V = Output value for channel 2 (V)

Example 1:

```
> atest
```

```
2.412    6301
1.943    5090
>
```

Example 2:

```
> atest 1.5 1.5
1.500    3948
1.500    3948
>
```

AERR

Use the **AERR** serial line command to set or view the error output from analog outputs.

AERR [CH0ERR/CH1ERR]

where

CH0ERR = Analog output

CH1ERR = Analog output

Example:

```
>aerr
Ch0 error out : 10.000V ? 0
Ch1 error out : 1.000V ? 0
>
```

NOTE

The error output value must be within a valid range of the output mode.

NOTE

The error output value is displayed only when there are minor electrical faults such as humidity sensor damage. When there is a severe device malfunction, the error output value is not necessarily shown.

ADDR

Addresses are required only for POLL mode (see serial line command SMODE on page 37). Use the **ADDR** command to input the RS-485 transmitter address. Without parameters, **ADDR** command displays current transmitter address. When a parameter is specified, it sets the transmitter address to the given value.

ADDR [0...99]

where

0...99= address (default = 0)

Example: the transmitter is configured to address 2.

```
>addr
Address      : 0 ? 2
>
```

OPEN

When all transmitters on the RS-485 bus are in POLL mode, the **OPEN** command sets one transmitter temporarily to STOP mode so that other commands can be entered.

OPEN [ADDR]

where

ADDR =address of the transmitter (0 ... 99)

CLOSE

The **CLOSE** command places the probe in temporary POLL mode. After this only addressable commands can be used.

Example:

```
>close
line closed
```

Sensor Functions

The active output version of HMP155 includes optional functions such as chemical purge and sensor heating. These functions are described in more detail in this section.

Chemical Purge (Optional)

In some specific applications the sensor gain may decrease gradually due to an interference caused by a particular chemical present in the measured gas, for example. The decrease of sensor gain due to an interfering chemical and the effect of the chemical purge process are illustrated below, see Figure 11 below. The sensor polymer absorbs the interfering chemical; and this reduces the ability of the polymer to absorb water molecules and consequently the sensor gain decreases. In chemical purge, heating the humidity sensor to a temperature level of approximately +180 °C for several minutes evaporates the interfering chemical.

The purge function starts with heating stage, continues with settling and when the temperature of the sensor is decreased, the probe returns to normal mode. The whole cycle takes about 6 minutes.

NOTE

Chemical purge function locks the output values for about 6 minutes.

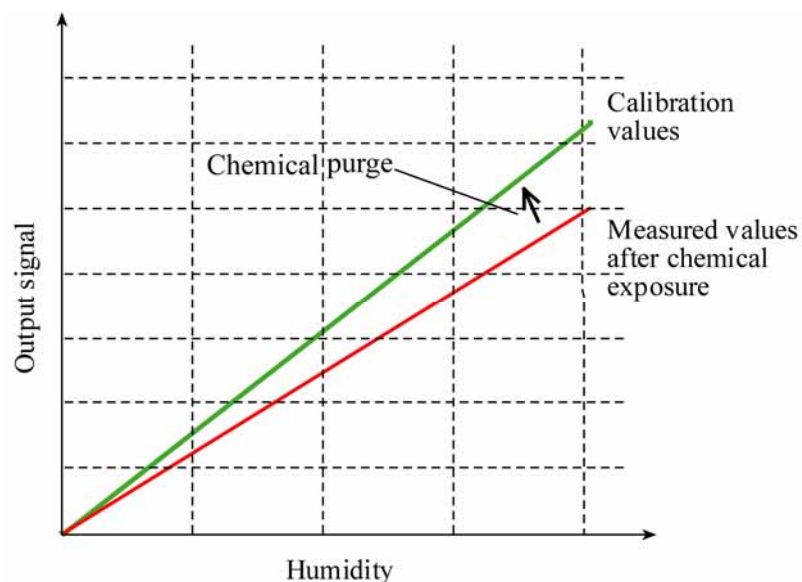

0508-035

Figure 11 Decrease of Sensor Gain

Automatic Chemical Purge (Interval Purge)

When HMP155 leaves the factory the automatic chemical purge takes place repeatedly with the time intervals set in the factory, if this option is chosen. You can change the interval in which the purge takes place by using serial commands. This can be necessary if the measuring environment contains high concentrations of interfering chemicals. The automatic chemical purge can also be turned off if necessary.

Manual Chemical Purge

The chemical purge must be performed always before RH calibration (see section Calibration and Adjustment on page 57) or when there is a reason to believe that a sensor has become exposed to an interfering chemical. Manual chemical purge can be activated by turning the power up purge on temporarily and resetting the probe. After the operation, the power up purge can be turned off, see PUR command on page 47. Make sure that the temperature of the sensor has come down to normal temperature before starting a calibration.

Chemical Purge in Power Up

Chemical purge (start-up purge) can be set to start within 10 seconds from the power-up of the device.

Starting and Configuring Chemical Purge

In this section, the function and use of the chemical purge option is explained.

PUR

With **PUR** command, you can enable or disable automatic and power-up chemical purge and set the interval for automatic purge. If the sensor is exposed to chemicals it is recommended to have the chemical purge done at least once in 720 min (=12 hours). In applications where the chemical exposure is not likely, the interval can be longer.

Type **PUR** and press **Enter** to proceed. The maximum interval is 14400 minutes (=10 days).

Example:

```
>pur
Interval Purge : OFF ?
Interval       : 720 min ?
Power-up Purge : OFF ?
Duration      : 240 s ?
Settling      : 240 s ?
Temperature    : 180 'C ?
>
```

NOTE

To activate the new interval settings immediately, reset the probe.

NOTE

When chemical purge in power-up is enabled, wait about 6 min after power-up before taking measurements. The output channels are locked for the first operation minutes to the initial measured values.

Sensor Heating

This function is optionally available only in probes with HUMICAP®180RC sensor. It should be used only with the heated probe.

The sensor heating is recommended for the high humidity environments where even small temperature differences can cause water to condense on the sensor. The sensor heating speeds up the recovery of the humidity sensor from condensation.

Sensor heating starts-up when the relative humidity of the measuring environment reaches the RH-value set by a user (RH-limit). You can define the RH-sensor heating temperature as well as the duration of the heating.

After the heating cycle, the humidity conditions are checked and new sensor heating is performed if the predefined conditions are reached again.

NOTE

During the sensor heating, the outputs are locked to the values measured before the heating cycle.

Setting Humidity Sensor Heating

When the HMP155 leaves the factory, the sensor heating follows the factory default values. You can enable or disable the function, change the RH-limit and define the heating temperature and duration of this function.

XHEAT

Enables or disables the sensor heating.

Example:

```
>xheat on
Extra heat      : ON
>xheat off
Extra heat      : OFF
>
```

To configure the sensor heating, use the **XHEAT** command without parameters. Enter the values after the question mark. The available ranges include the following:

Extra heat RH -limit (heating function starts-up above the setpoint)	0 ... 100 %RH (default: 95 %RH)
Extra heating temperature	0 ... 200 °C (default: 100 °C)
Extra heating time	0 ... 255 s (default: 30 s)

To see the current values, use the **XHEAT *** command.

Example:

```
>xheat *
Extra heat      :      OFF
RH limit        :      95 %RH
Temperature     :      100 'C
Duration        :      30  s
>
```

NOTE

After the defined XHEAT duration, there is an additional cooling time of 10 seconds before outputs are updated.

This page intentionally left blank.

CHAPTER 5

MAINTENANCE

This chapter contains information that is needed in basic maintenance of the product.

Periodic Maintenance

Cleaning

Clean the probe with a soft, lint-free cloth moistened with mild detergent.

Changing the Probe Filter

1. Remove the filter from the probe.
2. After removing the filter, check the O-ring and change it if necessary. See Figure 12 on page 53.
3. Install a new filter on the probe.

New filters can be ordered from Vaisala, see section Options and Accessories on page 76.

Changing the Sensor

You can change the HUMICAP[®] sensor yourself and the probe does not have to be sent in for service for a sensor change.

NOTE

Both HUMICAP[®]180 and HUMICAP[®]180R sensors can be changed, but you must never replace a HUMICAP[®]180 sensor with a HUMICAP[®]180R sensor or vice versa.

To change the sensor:

1. Remove the filter from the probe. See the instructions in section Changing the Probe Filter on page 51.
2. After removing the filter, check the O-ring and change it if necessary. See Figure 12 on page 53.
3. Remove the damaged sensor and insert a new one. Handle the new sensor by the plastic socket. **DO NOT TOUCH THE SENSOR PLATE.**
4. After sensor change the humidity calibration must be done according to the instructions, see section Relative Humidity Adjustment after Sensor Change on page 65.
5. Attach a new filter on the probe.



0802-159

Figure 12 Changing the Sensor

The following numbers refer to Figure 12 above:

- 1 = Filter
- 2 = O-ring
- 3 = HUMICAP[®] sensor
- 4 = Pt100 temperature sensor

Error States

In an error state, the quantity is not measured and the output is shown as follows:

- Analog channel outputs 0 V (you can use the **AERR** serial line command to change this fault indication value, see section AERR on page 44).
- The serial port outputs stars (***)

You can also check the error message via the serial interface by using the **ERRS** command. In case of constant error, please contact Vaisala, see Vaisala Service Centers on page 56.

Sometimes it is possible that the transmitter is not responding after startup due to an error. If this happens, change the bauds to 19200 N 8 1 and then execute the **ERRS** command to see what error caused the problem.

The possible error messages of HMP155 are listed in Table 14 below.

Table 14 Error Messages

Error Message	Description	Action
T MEAS error	Error in temperature measurement	Check the HUMICAP [®] sensor.
T REF error	Error in temperature measurement	Contact Vaisala Service Center, see page 56.
TA MEAS error	Error in T-probe measurement	Check the additional temperature probe.
TA REF error	Error in T-probe measurement	Contact Vaisala Service Center, see page 56.
F MEAS error	Error in humidity measurement	Check the HUMICAP [®] sensor.
F REF1 error	Error in humidity measurement	Contact Vaisala Service Center, see page 56.
F REF3 error	Error in humidity measurement	Contact Vaisala Service Center, see page 56.
Program flash checksum error	Internal error	Contact Vaisala Service Center, see page 56.
Parameter flash checksum error	Internal error	Contact Vaisala Service Center, see page 56.
INFOA checksum error	Internal error	Contact Vaisala Service Center, see page 56.
SCOEFS checksum error	Internal error	Contact Vaisala Service Center, see page 56.

Technical Support

For technical questions, contact the Vaisala technical support:

E-mail helpdesk@vaisala.com

Fax +358 9 8949 2790

Return Instructions

If the product needs repair, please follow the instructions below to speed up the process and to avoid extra costs to you.

1. Read the section Warranty on page 9.
2. Contact Vaisala Service Center or a local Vaisala representative. The latest contact information and instructions are available from www.vaisala.com. Addresses of the Service Centers are provided in section Vaisala Service Centers on page 56.

Please have the following information on hand:

- serial number of the unit
 - date and place of purchase or last calibration
 - description of the fault
 - circumstances in which the fault occurs/occurred
 - name and contact information of a technically competent person who can provide further information on the problem
3. Pack the faulty product in a strong box of adequate size, with proper cushioning material to avoid damage.
 4. Include the information specified in step 2 in the box with the faulty product. Also include a detailed return address.
 5. Ship the box to the address specified by your Vaisala contact.

Vaisala Service Centers

Vaisala Service Centers perform calibrations and adjustments as well as repair and spare part services. See contact information below.

Vaisala Service Centers also offer accredited calibrations, maintenance contracts, and a calibration reminder program. Do not hesitate to contact them to get further information.

NORTH AMERICAN SERVICE CENTER

Vaisala Inc., 10-D Gill Street, Woburn, MA 01801-1068, USA.

Phone: +1 781 933 4500, Fax: +1 781 933 8029

E-mail: us-customersupport@vaisala.com

EUROPEAN SERVICE CENTER

Vaisala Instruments Service, Vanha Nurmijärventie 21 FIN-01670 Vantaa, FINLAND.

Phone: +358 9 8949 2658, Fax: +358 9 8949 2295

E-mail: instruments.service@vaisala.com

TOKYO SERVICE CENTER

Vaisala KK, 42 Kagurazaka 6-Chome, Shinjuku-Ku, Tokyo 162-0825, JAPAN.

Phone: +81 3 3266 9617, Fax: +81 3 3266 9655

E-mail: aftersales.asia@vaisala.com

BEIJING SERVICE CENTER

Vaisala China Ltd., Floor 2 EAS Building, No. 21 Xiao Yun Road, Dongsanhuan Beilu, Chaoyang District, Beijing, P.R. CHINA 100027.

Phone: +86 10 8526 1199, Fax: +86 10 8526 1155

E-mail: china.service@vaisala.com

www.vaisala.com

CHAPTER 6

CALIBRATION AND ADJUSTMENT

The Vaisala HUMICAP[®] Humidity and Temperature Probe HMP155 is fully calibrated and adjusted as shipped from factory. Recommended calibration interval is one year. Depending on the application, it is good to make more frequent checks. Calibration must always be done when there is reason to believe that the device is not within the accuracy specifications.

It is recommended that calibration and adjustment is carried out by Vaisala. See section Vaisala Service Centers on page 56.

Calibration and adjustment can also be carried out either by using the buttons on the probe or through the serial line connection.

NOTE

Vaisala recommends that RH adjustment is carried out as a two-point adjustment. With one-point adjustment, the required accuracy can only be achieved if the actual measurement environment (RH and T) is the same as the one-point adjustment environment.

Before attempting calibration, the **ADJ** button has to be held down until a green LED lights up. This turns off the heating and the additional temperature probe in the case you are using an HMP155 with either of those options. After that HMP155 is ready to be checked and calibrated. When the T-probe is turned off during calibration, it does not need to be inserted into the same reference conditions with the humidity probe.

If a chemical purge option is available, it should always be carried out before calibration.

NOTE

Button calibration is not available for the additional temperature probe. In the passive output version of HMP155, the temperature cannot be calibrated.

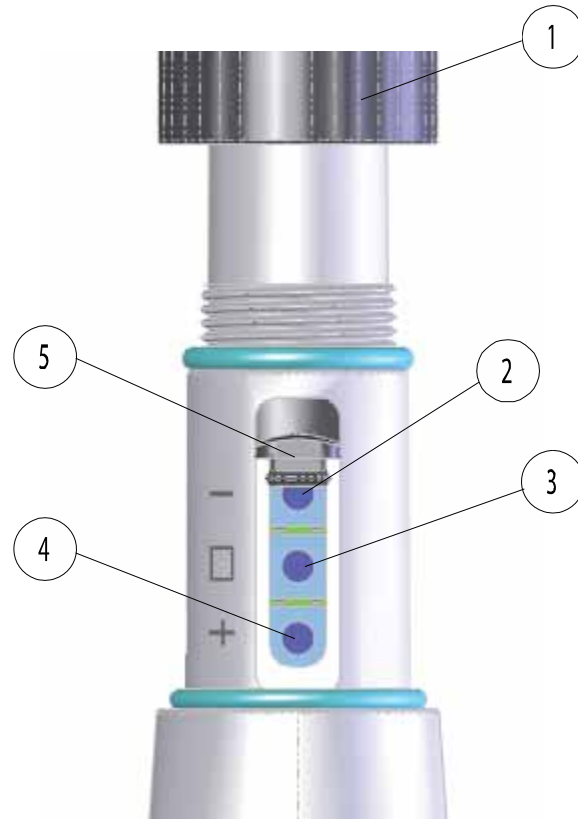

0801-076

Figure 13 HMP155 Adjustment Buttons

The following numbers refer to Figure 13 above:

- 1 = Protective cover
- 2 = Down button
- 3 = ADJ button
- 4 = Up button
- 5 = Protective plug

There is a two-colour indicator LED located under the protective plug and next to the **Down** button, see Figure 13 above. The LED is green and red.

NOTE

If you are using a warmed probe (HMP155 active output version option), probe heating will be interrupted when **ADJ** button is pressed, see Figure 13 on page 58. Allow sufficient time for the probe to reach ambient temperature before starting the adjustment procedure.

NOTE

Fixed pressure compensation value of 1.01325 bar is used when in adjustment mode.

Push-Button Calibration

Calibration and adjustment of the HMP155 can be done by using the adjustment buttons found on the probe. The two-point humidity adjustment is carried out by using two relative humidity references: for example saturated salt points 11 % RH (LiCl) and 75 % RH (NaCl). The difference between the two humidity reference points must be at least 30 %RH. The difference between the two temperature reference points must be at least 30 °C.

NOTE

In push-button calibration, the probe outputs are by default relative humidity in the range 0...100 %RH in CH1 and temperature in the range -40...+60°C in CH2.

Two-Point Humidity and Temperature Adjustment

To make a humidity or temperature adjustment:

1. Carry out the chemical purge (if available).
2. Uncover the adjustment buttons on the probe by removing the protective cover and removing the calibration seal.
3. Open the protective plug and you can see three buttons marked -, □ and +. There is also a two-coloured indicator LED. See Figure 13 on page 58.
4. Press the **ADJ** button and hold it down until the green indicator LED lights up. This puts HMP155 in RH calibration mode.

5. Remove the filter and insert the probe into a measurement hole of the dry end reference chamber (for example, LiCl: 11 % RH) to do the low humidity offset adjustment.

NOTE

Do not touch the adjustment buttons before the conditions have stabilized. This takes approximately 30 minutes.

6. Using the - and + buttons, make sure the A_{out} voltage is correct and press the **ADJ** button. Green indicator LED turns off and back on.

NOTE

Do not touch the adjustment buttons before the conditions have stabilized.

7. Insert the probe into the high end reference chamber (for example, NaCl: 75 % RH chamber in the humidity calibrator HMK15) and do the high humidity gain adjustment by using the - and + buttons to make sure the A_{out} voltage is correct. To finish the RH calibration, press the **ADJ** button and the red indicator LED lights up.

NOTE

If you do not wish to perform the temperature adjustment at this time, press **ADJ** -button two times and the indicator LED turns off. After reset, HMP155 exits the calibration mode. Otherwise, continue following the instructions from step 8 onwards.

8. Insert the probe into a known reference temperature (if HMK15 Humidity Calibrator is not used) and let the temperature reading stabilize.

NOTE

Do not touch the adjustment buttons before the conditions have stabilized.

9. Using the - and + buttons, make the temperature offset adjustment by making sure the A_{out} voltage is correct and press the **ADJ** button. Red indicator LED turns off and back.

NOTE

If you do not wish to perform the two-point temperature adjustment at this time, press the **ADJ** button one more time so that the red indicator LED turns off. After reset, HMP155 exits the calibration mode. Otherwise, continue following the instructions from step 10 onwards.

10. Insert the probe into another reference temperature.

NOTE

Do not touch the adjustment buttons before the conditions have stabilized.

11. Using the - and + buttons, make the temperature gain adjustment by making sure the A_{out} voltage is correct.
12. Press the **ADJ** button and the red indicator LED turns off.

One-Point Humidity and Temperature Adjustment

To make a one-point humidity or temperature adjustment:

1. Carry out the chemical purge (if available).
2. Uncover the adjustment buttons on the probe by removing the protective cover and removing the calibration seal.
3. Open the protective plug and you can see three buttons marked -, \square and +. There is also a two-coloured indicator LED. See Figure 13 on page 58.
4. Remove the filter and insert the probe into a measurement hole of the salt chamber to do the humidity adjustment.
5. Press the **ADJ** button and hold it down until the green indicator LED lights up. This puts HMP155 in RH calibration mode.

NOTE

Do not touch the adjustment buttons before the conditions have stabilized.

6. Using the - and + buttons, make sure the A_{out} voltage is correct and press the **ADJ** button. Green indicator LED turns off and back on.

7. To move on to the temperature adjustment, press the **ADJ** button once and the red indicator LED lights up.
8. Insert the probe into the reference temperature.

NOTE

Do not touch the adjustment buttons before the conditions have stabilized.

9. Using the - and + buttons, make the temperature offset adjustment by making sure the A_{out} voltage is correct and press the **ADJ** button. Red indicator LED turns off and back on.
10. Press the **ADJ** button one more time so that the red LED turns off to indicate the probe has quit the calibration mode.

Passive Output Version Push-Button Calibration

If you are operating a passive output version HMP155, the humidity calibration is carried out similarly to calibration of the active output version. After finishing the humidity adjustment, press the **ADJ** button twice until the LED turns off. Reset the probe to exit the calibration mode.

Serial Line Calibration

Two-Point Humidity Adjustment

Note that the difference between the two humidity references must be at least 30 %RH.

To make a humidity adjustment:

1. Connect the HMP155 to a PC. See section Serial Line Communication on page 24. Open a terminal program.
2. Carry out the chemical purge (if available).
3. Press the **ADJ** button and the green LED lights up.
4. Remove the filter from the probe and insert the probe into a measurement hole of the dry end reference chamber (for example, LiCl: 11 % RH).
5. Enter the **CRH** command and press **ENTER**.
6. Wait at least 30 minutes for the sensor to stabilize.
7. Press **ENTER** a few times to check if the reading has stabilized.
8. When the reading has stabilized, give the reference humidity after the question mark and press **ENTER**.

```
>crh
RH : 16.6675 1. ref ?
RH : 16.4978 1. ref ?
RH : 16.3956 1. ref ? 11.25
  Press any key when ready ...
RH : 11.25 Ref2 ?
```

9. Now the device is waiting for the high end reference. Insert the probe into the measurement hole of the high end reference chamber (for example, NaCl: 75 % RH chamber in the humidity calibrator HMK15). Press any key when ready.
10. Let the probe stabilize for about 30 minutes. You can follow the stabilization by pressing **ENTER**.
11. When stabilized, type the high end reference value after the question mark and press **ENTER**.

```
RH : 75.45 Ref2 ?
RH : 75.57 Ref2 ?
RH : 75.55 Ref2 ?
RH : 75.59 Ref2 ? 75.5
OK
```

12. **OK** indicates that the adjustment has succeeded and the new calibration coefficients are calculated and stored. Enter the adjustment information (date and text) to the memory of the transmitter; see the commands **CTEXT** and **CDATE**.
13. Reset the probe with the **RESET** command.
14. Take the probe out of the reference conditions and replace the filter.

Two-Point Temperature Adjustment

NOTE

In the passive output version of HMP155, the temperature cannot be calibrated.

Note that the difference between the two temperature references must be at least 30 °C.

To make a temperature adjustment:

1. Press the **ADJ** button to enable the adjustment mode. This lights up the green LED on the probe. If using a warmed probe for measuring, probe heating will be interrupted when **ADJ** button is pressed.
2. Wait some time for the probe to reach ambient temperature.
3. Enter the **CT** command (or **CTA** for additional T-probe) and press **ENTER**.
4. Press **ENTER** a few times to check if the reading is stabilized. Let the reading stabilize, give the reference temperature after the question mark and press **ENTER** three times.

Example (2-point adjustment):

```
>ct
T : 18.6038 1. ref ?
T : 18.6068 1. ref ?
T : 18.6098 1. ref ? 19.0
  Press any key when ready ...
T : 49.5176 2. ref ? 50.0
OK
>
```

5. Move the probe into another reference temperature and let the reading stabilize. Give the reference temperature after the question mark and press **ENTER**, see example above.

6. **OK** indicates that the calibration has succeeded. Enter the calibration information (date and text) to the transmitter's memory; see the serial commands **CTEXT** and **CDATE**.
7. Reset the probe with **RESET** command.

Relative Humidity Adjustment after Sensor Change

After sensor change, carry out the procedure as described in previous sections. Just replace the **CRH** command with the **FCRH** command.

FCRH

Example:

```
>fcrh
RH :    25.19  Ref1 ? 11.3
Press any key when ready ...
RH :    70.02  Ref2 ? 75.5
OK
>
```

The OK indicates that the calibration has been successful.

One-Point Humidity and Temperature Adjustment

One-point humidity and temperature adjustment can be done by using the following serial line commands:

- **CRH** and **FCRH** commands for humidity adjustment
- **CT** and **CTA** commands for temperature adjustment

To make an adjustment, just enter the command , press space bar and then enter the reference value, as in the example below.

Example:

```
Crh 20.0
OK
```

User Adjustment Commands

You can use the user adjustment commands to display and set parameters. You can only use **LI** command in ADJUST mode.

L

With the **L** command you can display user adjustment parameters.

Example:

```
>l
Cp offset : 0.00000000E+00
Cp gain   : 1.00000000E+00
T offset  : 0.00000000E+00
T gain    : 1.00000000E+00
Ta offset : 0.00000000E+00
Ta gain   : 1.00000000E+00
P offset  : 0.00000000E+00
P gain    : 1.00000000E+00
>
```

LI

With the **LI** command you can display and ask for new values for the user adjustment parameters.

Example:

```
>li
Cp offset : 0.00000000E+00 ?
Cp gain   : 1.00000000E+00 ?
T offset  : 0.00000000E+00 ?
T gain    : 1.00000000E+00 ?
Ta offset : 0.00000000E+00 ?
Ta gain   : 1.00000000E+00 ?
P offset  : 0.00000000E+00 ?
P gain    : 1.00000000E+00 ?
>
```

NOTE

If you suspect that something has gone wrong with the calibration, you can use the **LI** command to return the factory values by entering the values shown in the example above.

Feeding Adjustment Information

The information added with the serial line commands below is shown in the device information fields. You can only use **CTEXT** and **CDATE** commands in ADJUST mode. To put HMP155 in adjustment mode, just hold down the **ADJ** button until the green LED lights up.

CTEXT

Use the **CTEXT** command to enter text to the adjustment information field.

Example:

```
>ctext
Cal. info      : Helsinki / FIN ? Finland
>
```

CDATE

Use the **CDATE** command to enter date to adjustment information field. Set the adjustment date in format YYYYMMDD.

Example:

```
>cdate 20080320
>
```

Analog Output Adjustment

In the analog output calibration the analog output is forced to the following values:

- Voltage output: 10 % and 90 % of the range

Connect HMP155 to a calibrated voltage meter in order to measure voltage.

NOTE

Hold down the **ADJ** button until a green LED lights up. This puts the HMP155 in ADJUST mode.

NOTE

The serial line command ACAL cannot be used with HMP155 passive output version.

Enter the **ACAL** command and type the multimeter reading for each case. Continue by pressing **ENTER**. When a channel is specified, only the specified analog output channel is adjusted.

ACAL [0/1]

Example:

```
Ch 0:  
>acal 0  
U1 ( V ) ? 1.001  
U2 ( V ) ? 9.011  
  
Ch 1:  
>acal 1  
U1 ( V ) ? 2.0988  
U2 ( V ) ? 8.8997  
>
```

MI70 Check and Adjustment

Vaisala MI70 measurement indicator is an optional accessory that can be used as a display or as a communication device for HMP155. When it is used, HMP155 is powered via MI70.

With MI70 you can check the HMP155 easily on the field. Both the active output version and the passive output version (only RH displayed) can be checked with MI70.

In the active output version relative humidity, temperature and additional T-probe temperature can be calibrated. In the passive output version, only relative humidity calibration is possible.

To check and adjust HMP155 with MI70:

1. Connect HMP155 to MI70 by using a connection cable (Vaisala item 221801).
2. Turn MI70 on by pressing the power key and follow the instructions given on the display.

NOTE

When turning on the passive output version, always hold down the **ADJ** button simultaneously.

3. Activate the adjustment mode by holding down the **ADJ** button on the probe until the message below appears on the MI70 display.



4. Press **OK** to move on to the adjustment and select the quantity you want to adjust. The list of quantities displayed in the figure below vary according to the configuration of your HMP155.



5. Follow the instructions given on the display to finish the adjustment.

This page intentionally left blank.

CHAPTER 7

TECHNICAL DATA

This chapter provides the technical data of the product.

Performance

Relative Humidity

Measurement range	0 ... 100 %RH
Accuracy (including non-linearity, hysteresis and repeatability)	
at +15 ... 25 °C (59 ... 77 °F)	± 1 % RH (0 ... 90 % RH) ± 1.7 % RH (90 ... 100 %RH)
at -20 ... +40 °C (-4 ... 104 °F)	± (1.0 + 0.008 × reading) % RH
at -40 ... -20 °C (-40 ... -4 °F)	± (1.2 + 0.012 × reading) % RH
at +40 ... +60 °C (104 ... 140 °F)	± (1.2 + 0.012 × reading) % RH
at -60 ... -40 °C (-76 ... -40 °F)	± (1.4 + 0.032 × reading) % RH
Factory calibration uncertainty (+20 °C)	±0.6 % RH (0 ... 40 % RH) ±1.0 % RH (40 ... 97 % RH) (Defined as ± 2 standard deviation limits. Small variations possible, see also calibration certificate.)
Recommended humidity sensor	
HUMICAP®180R	for typical applications
HUMICAP®180RC	for applications with chemical purge and/or warmed probe
Response time for HUMICAP®180R(C)	
at 20 °C in still air with sintered PTFE filter	
63 %	20 s
90 %	60 s

Temperature

Measurement range	-80 ... +60 °C (-112 ... +140 °F)
Accuracy with voltage output	
at -80 ... +20 °C	$\pm(0.226 - 0.0028 \times \text{temperature}) \text{ } ^\circ\text{C}$
at +20 ... +60 °C	$\pm(0.055 + 0.0057 \times \text{temperature}) \text{ } ^\circ\text{C}$
Accuracy with passive (resistive) output	
According to IEC 751 1/3	
Class B	$\pm (0.1 + 0.00167 \times \text{temperature}) \text{ } ^\circ\text{C}$
Accuracy with RS-485 output	
at -80 ... +20 °C	$\pm(0.176 - 0.0028 \times \text{temperature})$
at +20 ... +60 °C	$\pm(0.07 + 0.0025 \times \text{temperature})$

See graph below

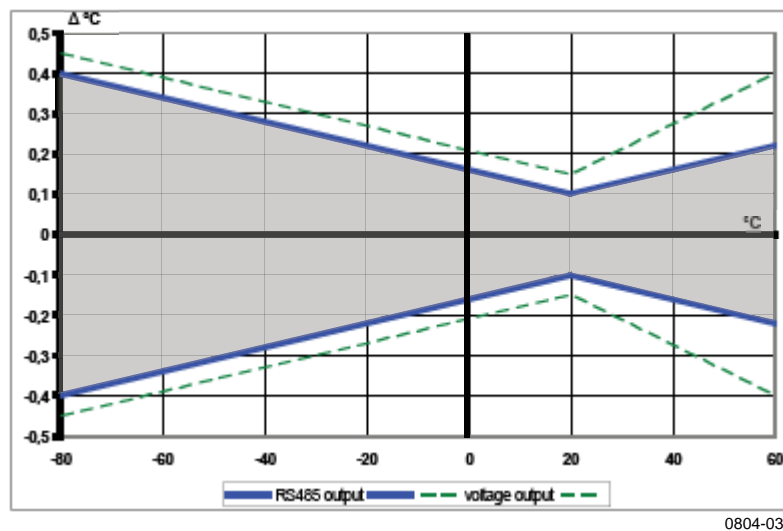

Figure 14 Accuracy over Temperature Range: Voltage and RS-485

Temperature sensor	Pt 100 RTD 1/3 Class B IEC 751
Response time (63 %) for additional temperature probe in 3 m/s air flow	
63 %	< 20 s
90 %	< 35 s

Operating Environment

Operating temperature range for humidity measurement	-80 ... +60 °C (-112 ... +140 °F)
Storage temperature range	-80 ... +60 °C (-112 ... +140 °F)
Electromagnetic compatibility	Complies with EMC standard EN61326-1, Electrical equipment for measurement control and laboratory use - EMC requirements for use in industrial locations.

Calculated Variables

Table 15 Calculated Variables

Quantity	Abbreviation	Metric Unit	Non Metric Unit
Dewpoint / Frostpoint Temperature ($T_{d/f}$)	TDF	°C	°F
Dewpoint Temperature (T_d)	TD	°C	°F
Mixing ratio (x)	X	g/kg	gr/lb
Wetbulb temperature (T_w)	TW	°C	°F

Accuracies of Calculated Variables

Accuracies of the calculated variables depend on the calibration accuracy of the humidity and temperature sensors; here the accuracies are given for $\pm 2\%$ RH and $\pm 0.2\text{ °C}$.

Accuracy of Dewpoint Temperature °C

Temp.	Relative humidity									
	10	20	30	40	50	60	70	80	90	100
-40	1.86	1.03	0.76	0.63	0.55	0.50	0.46	0.43	—	—
-20	2.18	1.19	0.88	0.72	0.62	0.56	0.51	0.48	—	—
0	2.51	1.37	1.00	0.81	0.70	0.63	0.57	0.53	0.50	0.48
20	2.87	1.56	1.13	0.92	0.79	0.70	0.64	0.59	0.55	0.53
40	3.24	1.76	1.27	1.03	0.88	0.78	0.71	0.65	0.61	0.58
60	3.60	1.96	1.42	1.14	0.97	0.86	0.78	0.72	0.67	0.64

Accuracy of Mixing Ratio g/kg (Ambient Pressure 1013 mbar)

Temp.	Relative humidity									
	10	20	30	40	50	60	70	80	90	100
-40	0.003	0.003	0.003	0.003	0.003	0.004	0.004	0.004	—	—
-20	0.017	0.018	0.019	0.021	0.022	0.023	0.025	0.026	—	—
0	0.08	0.09	0.09	0.10	0.10	0.11	0.11	0.12	0.13	0.13
20	0.31	0.33	0.35	0.37	0.39	0.41	0.43	0.45	0.47	0.49
40	0.97	1.03	1.10	1.17	1.24	1.31	1.38	1.46	1.54	1.62
60	2.68	2.91	3.16	3.43	3.72	4.04	4.38	4.75	5.15	5.58

Accuracy of Wet Bulb Temperature °C

Temp.	Relative humidity									
	10	20	30	40	50	60	70	80	90	100
-40	0.20	0.20	0.20	0.20	0.20	0.20	0.20	0.20	—	—
-20	0.21	0.21	0.22	0.22	0.22	0.22	0.23	0.23	—	—
0	0.27	0.28	0.28	0.29	0.29	0.29	0.30	0.30	0.31	0.31
20	0.45	0.45	0.45	0.44	0.44	0.44	0.43	0.43	0.42	0.42
40	0.84	0.77	0.72	0.67	0.64	0.61	0.58	0.56	0.54	0.52
60	1.45	1.20	1.03	0.91	0.83	0.76	0.71	0.67	0.63	0.60

Accuracy of Dewpoint Measurement

Find the intersection of the dewpoint temperature curve and the dewpoint difference reading (process temperature-dewpoint temperature) on the x-axis and read the accuracy in dewpoint measurement on the y-axis.

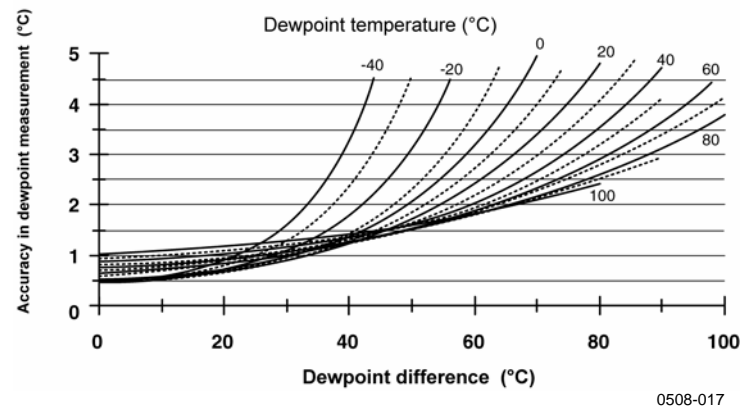

Figure 15 Accuracy of Dewpoint Measurement

Inputs and Outputs

Outputs	
Voltage output	0 ... 1 V, 0 ... 5 V, 0 ... 10 V
Resistive Pt100 4-wire connection	
RS-485	
Note: minimum operating voltages	
0...5 V output	12 V
0...10 V output, probe heating, chemical purge or XHEAT	16 V
Average current consumption (+15 VDC, load 100 kOhm))	
0...1 V output	< 3 mA
0...10 V output	+ 0.5 mA
RS-485	< 4 mA
During chemical purge	max. 110 mA
With warmed probe	max. 150 mA
Operating voltage	7 ... 28 VDC
Settling time at power-up	
Voltage output	2 s
RS-485	3 s

Mechanics

User cable connector	M12 series 8-pin connector (male)
Connection cable lengths	3.5 m, 10 m or 30 m
Cable coating	PUR
Max wire size	AWG 26
Additional temperature probe cable length	2 m
Additional temperature probe material	Stainless steel (AISI 316L)
Service cables	USB connection cable 1.45 m (Item 221040) MI70 connection cable (Item 221801)
Filter	Sintered PTFE
Housing material	PC
Housing classification	IP66
Weight	
Probe	86 g
3.5 m cable	159 g
30 m cable	1260 g

Options and Accessories

Table 16 Options and Accessories

Description	Item code
SENSORS	
HUMICAP180R	HUMICAP180R
HUMICAP180	HUMICAP180
FILTERS	
Sintered Teflon Filter + O-ring	219452SP
TRANSMITTER MOUNTING ACCESSORIES	
T-probe Installation Adapter for DTR13	221069
T-probe Installation Adapter for DTR502	221072
HMP155 and T-probe Installation Adapter for Stevenson Screen	221321
CONNECTION CABLES	
USB Cable	221040
MI70 Connection Cable	221801
Connection Cable 3.5m 8-pin M12	220496
Connection Cable 10m 8-pin M12	220497
Connection Cable 30m 8-pin M12	220498
OTHER	
Protection Set for Calibration Buttons: protective cover, 2 O-rings and protective plug	221318
HMK15 Humidity Calibrator with mercury thermometer	19729HM
HMK15 Humidity Calibrator with a thermometer with red capillary liquid	25130HM

Dimensions in mm (inches)

HMP155 Probe

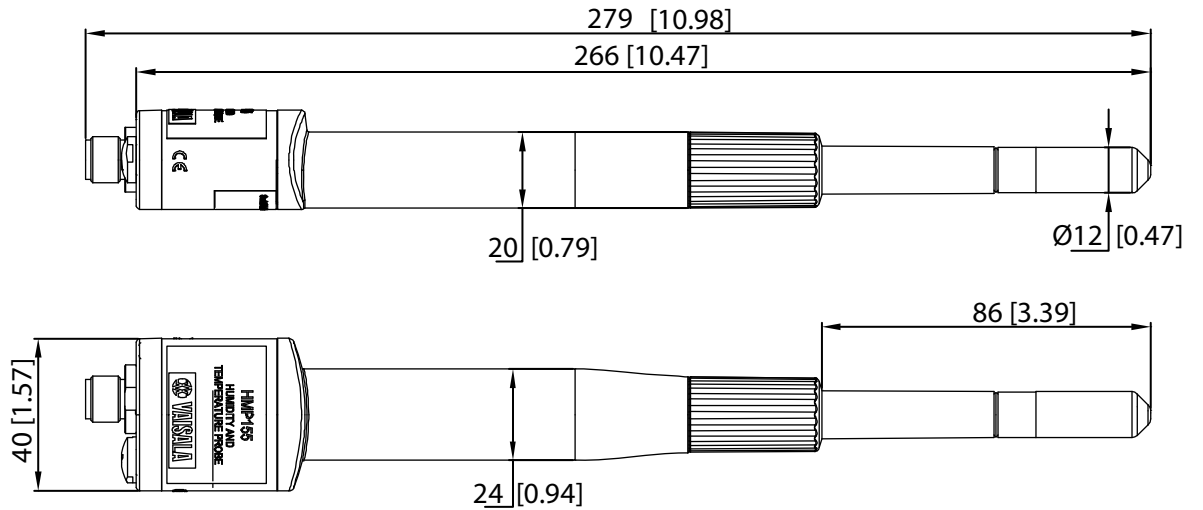

0801-077

Figure 16 Probe Dimensions

Additional Temperature Probe

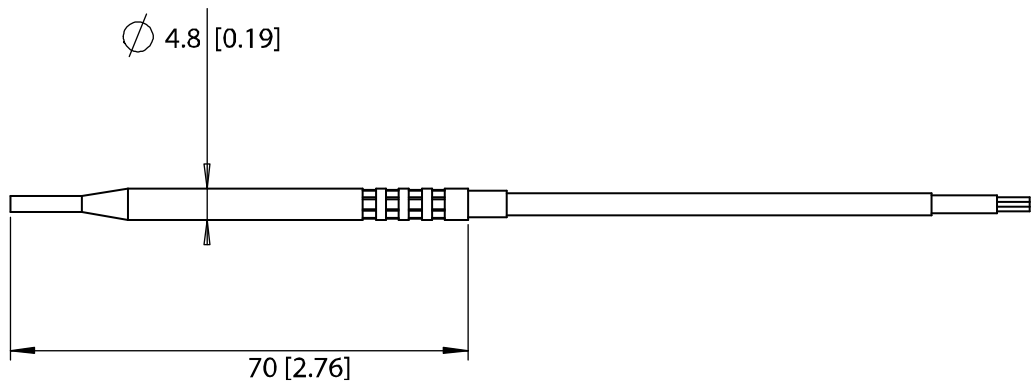

0801-078

Figure 17 Additional Temperature Probe Dimensions

This page intentionally left blank.

APPENDIX A

CALCULATION FORMULAS

This Appendix contains the formulas used for the calculated output quantities.

The HMP155 series probe measures relative humidity and temperature. From these values dewpoint and frostpoint, mixing ratio, wet bulb temperature, absolute humidity and enthalpy in normal pressure are calculated using the following equations:

Dewpoint/frostpoint:

$$T_{d/f} = \frac{237.3}{\left(\frac{7.5}{10 \log \left(\frac{P_w}{6.1078} \right) - 1} \right)} + 273.15 \quad (1)$$

P_w is the water vapor pressure. Dewpoint/frostpoint is measured in Kelvin.

Mixing ratio:

$$x = 621.99 \times \frac{P_w}{p - P_w} \quad (2)$$

Absolute humidity:

$$A = C \times \frac{P_w}{T} \quad (3)$$

where

$$C = 216.679$$

Enthalpy:

$$h = T \cdot (1.01 + 0.00189 \cdot x) + 2.5 \cdot x \quad (4)$$

The water vapor saturation pressure at temperature T_{pws} is calculated over water and over ice by using four equations (5-8). These formulas are taken from Hyland, R., Wexler, A.: *Formulations of the Thermodynamic Properties of the Saturated Phases of H₂O from 173.15 K to 473.15 K*, Ashrae transactions 1983, Part 2A, pp 500-513.

PWS over water:

$$\Theta = T - \sum_{i=0}^3 C_i T_{pws}^i \quad (5)$$

PWS over ice:

$$\Theta = T_{pws} \quad (6)$$

where:

$$\begin{aligned} T_{pws} &= \text{temperature in K} \\ C_i &= \text{coefficients} \\ C_0 &= 4.931358 \\ C_1 &= -0.46094296 * 10^{-2} \\ C_2 &= 0.13746454 * 10^{-4} \\ C_3 &= -0.12743214 * 10^{-7} \end{aligned}$$

Over water:

$$100 \times \ln P_{wsWATER} = \frac{b_{-1}}{\Theta} + \sum_{b=0}^3 b_i \Theta^i + b_4 \ln \Theta \quad (7)$$

Over ice:

$$100 \times \ln P_{wsICE} = \frac{a_{-1}}{\Theta} + \sum_{a=0}^4 a_i \Theta^i + a_6 \ln \Theta \quad (8)$$

where:

$$\begin{aligned} b_i &= \text{Coefficients over water} \\ b_{-1} &= -0.58002206 * 10^4 \\ b_0 &= 0.13914993 * 10^1 \\ b_1 &= -0.48640239 * 10^{-1} \\ b_2 &= 0.41764768 * 10^{-4} \\ b_3 &= -0.14452093 * 10^{-7} \\ b_4 &= 0.65459673 * 10^1 \\ a_i &= \text{Coefficients over ice} \\ a_{-1} &= -0.56745359 * 10^4 \\ a_0 &= 0.63925247 * 10^1 \\ a_1 &= -0.96778430 * 10^{-2} \\ a_2 &= 0.62215701 * 10^{-6} \\ a_3 &= 0.20747825 * 10^{-8} \\ a_4 &= -0.94840240 * 10^{-12} \\ a_6 &= 0.41635019 * 10^1 \end{aligned}$$

The water vapor pressure is calculated using:

$$P_w = RH \cdot \frac{P_{ws}}{100} \quad (9)$$

Parts per million by volume is calculated using:

$$ppm_v = 10^6 \cdot \frac{P_w}{(p - P_w)} \quad (10)$$

Symbols:

T_d	=	dewpoint temperature (°C)
P_w	=	water vapor pressure (hPa)
P_{ws}	=	water vapor saturation pressure (hPa)
RH	=	relative humidity (%)
x	=	mixing ratio (g/kg)
p	=	atmospheric pressure (hPa)
A	=	absolute humidity (g/m ³)
T	=	temperature (K)
h	=	enthalpy (kJ/kg)
Θ	=	virtual temperature



www.vaisala.com