

Installation and Setting-Up Instructions Spare Parts List

Contents:

1 INSTALLATION

- 1.1 Mechanical installation
- 1.2 Electrical connections

2 SETTING UP

- 2.1 Using the 275 user interface
- 2.2 Setting up through HART® 275 user interface
- 2.3 Setting up with Satron-pAdvisor Service Software
- 2.4 Setting up with local switches
- 2.5 Set-up calibration

3 CALIBRATION

- 3.1 Adjustability
- 3.2 Damping
- 3.3 Calibration examples

4 CONSTRUCTION AND OPERATION

5 PARTS LIST



DOCUMENTS

Technical Specifications: BPV710
Installation and Setting-Up Instructions: BPV710AV

We reserve the right for technical modifications without prior notice.
HART® is a registered trademark of HART Communication Foundation.
Hastelloy® is the registered trademark of Haynes International.
Viton® is the registered trademark of DuPont Down Elastomers.



Satron Instruments Inc.

P.O.Box 22, FIN-33901 Tampere, Finland
Tel.int. +358 207 464 800, Telefax +358 207 464 801
www.satron.com, info@satron.com

1. INSTALLATION AND PUTTING INTO OPERATION

1.1 Mechanical installation

1.1.1 Recommended mounting positions

- Process connection direction: horizontal
- Cable entry direction: from below
- Connector coupling direction, calibration direction: horizontal

Other considerations:

- In outdoor installations you should make sure that water condensed from e.g. a steam line will not freeze and, by expanding, damage the transmitter's sensor diaphragm. For instance, this can be avoided by installing heat insulation up to the sensor diaphragm.

NOTE
Dimensions are in millimeters

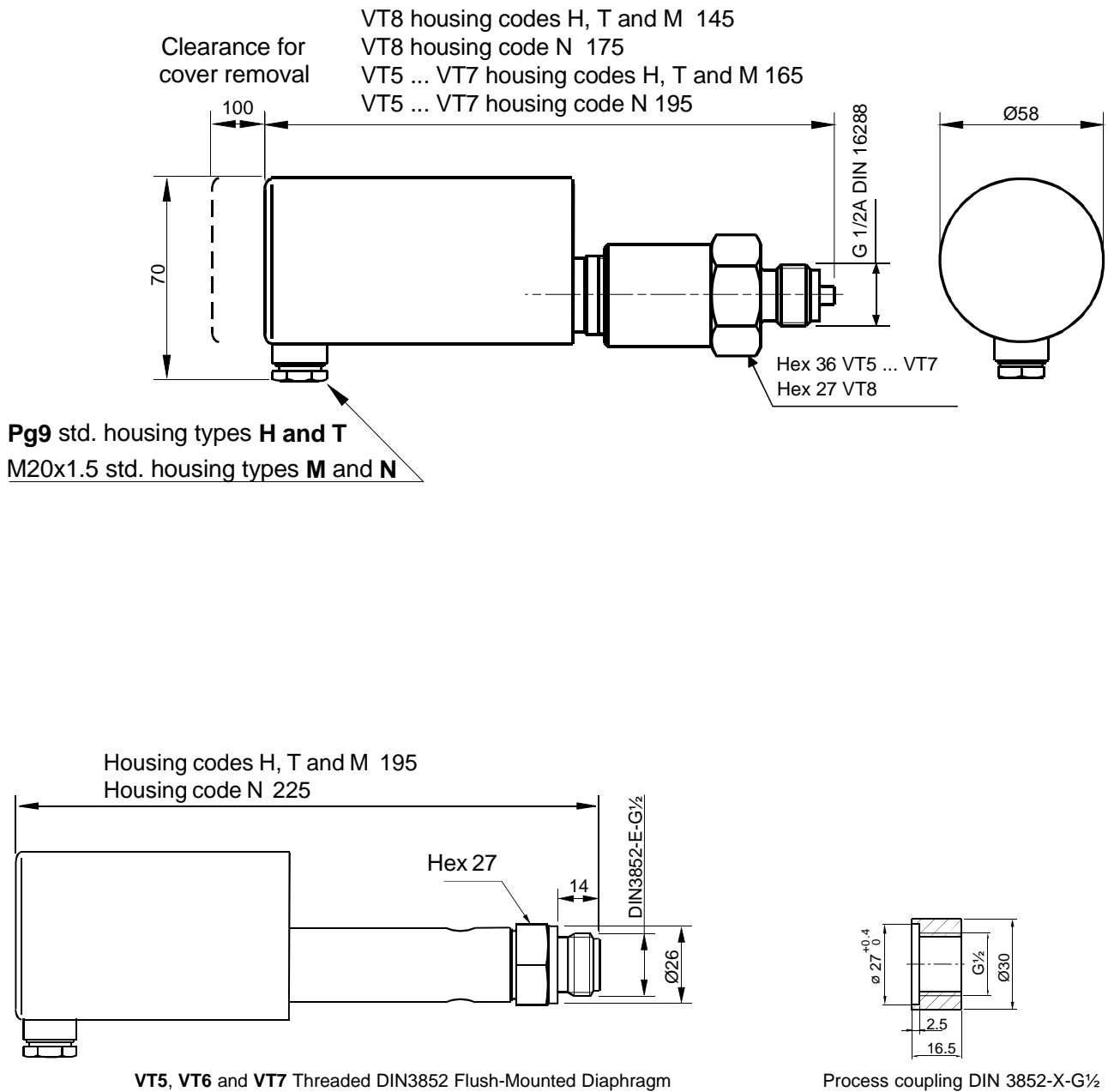

Figure 1-1 Basic mounting dimensions
(cont. on next page)

1300354152

SATRON VT pressure transmitter

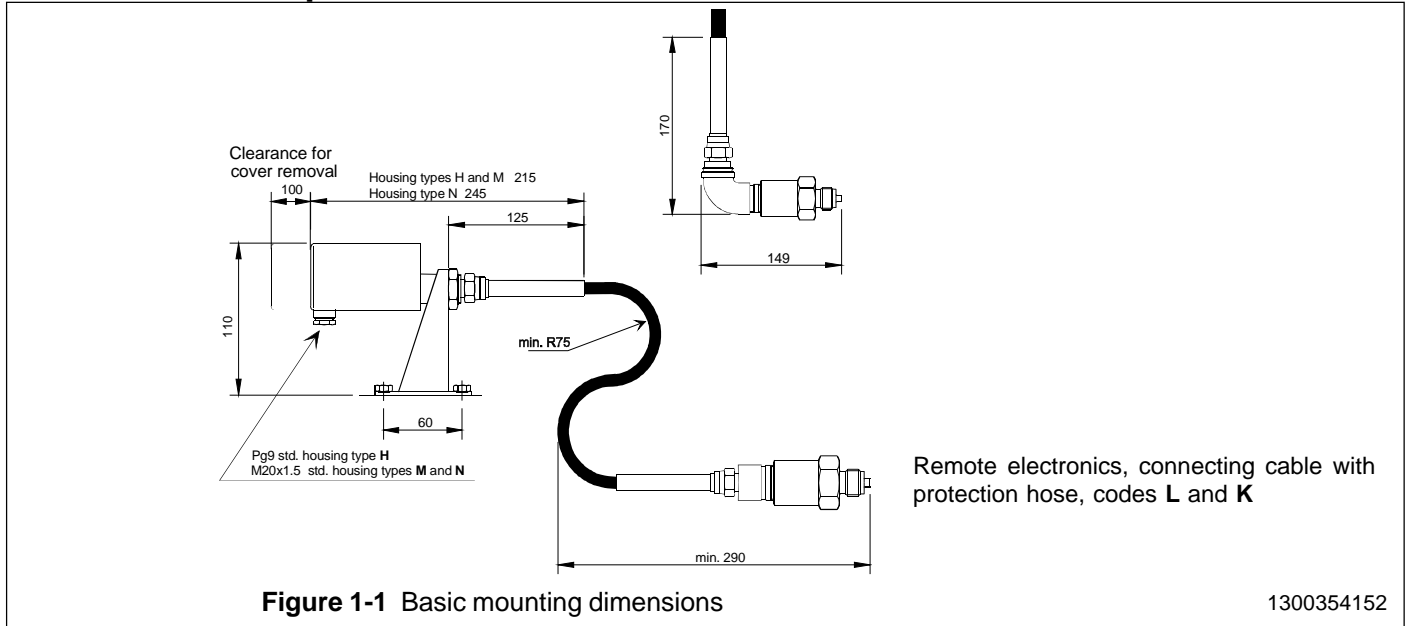

Figure 1-1 Basic mounting dimensions

1300354152

1.1.2 Impulse piping

The process medium and the transmitter's position in relation to the process pipe determine the impulse piping line.

- For liquid and steam pressure measurements it is preferable to install the transmitter below orifice plate to prevent the formation of disturbing gas bubbles in the impulse piping.

If the transmitter has to be installed above the process pipe for reasons of accessibility or for some other compelling reasons, it is recommendable to provide the piping with a gas seal to avoid disturbance.

- Mounting the transmitter above the process pipe in gas pressure measurement will eliminate disturbances caused by condensing liquid.
- Steam should not be admitted to the transmitter's sensing element. See installation examples 1-2c and d.

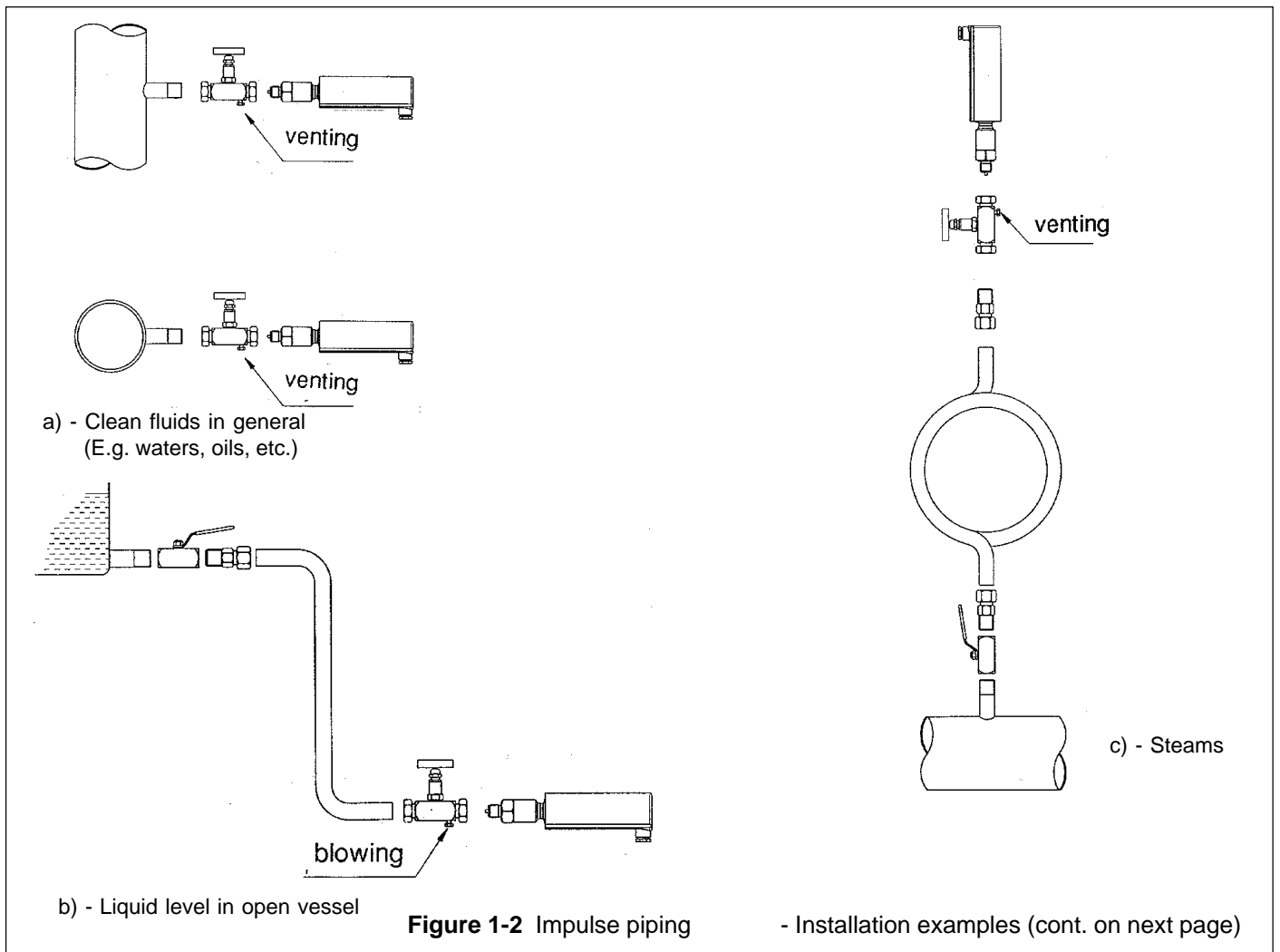

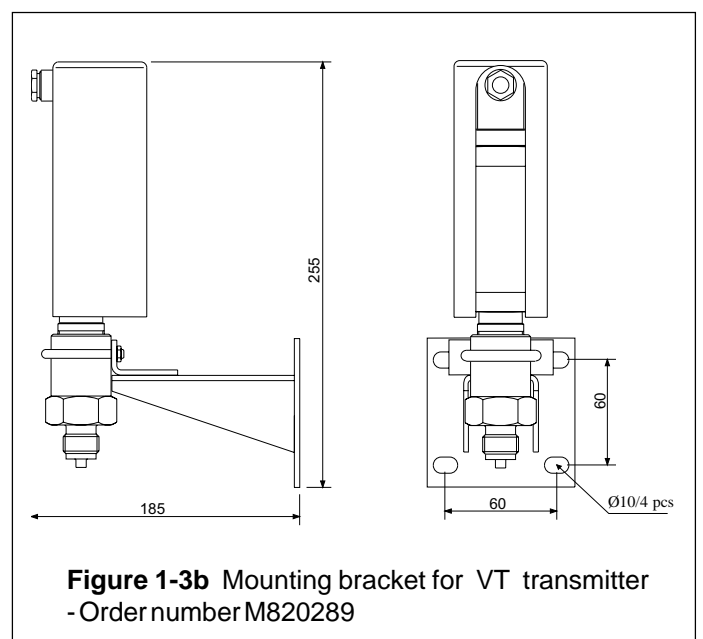
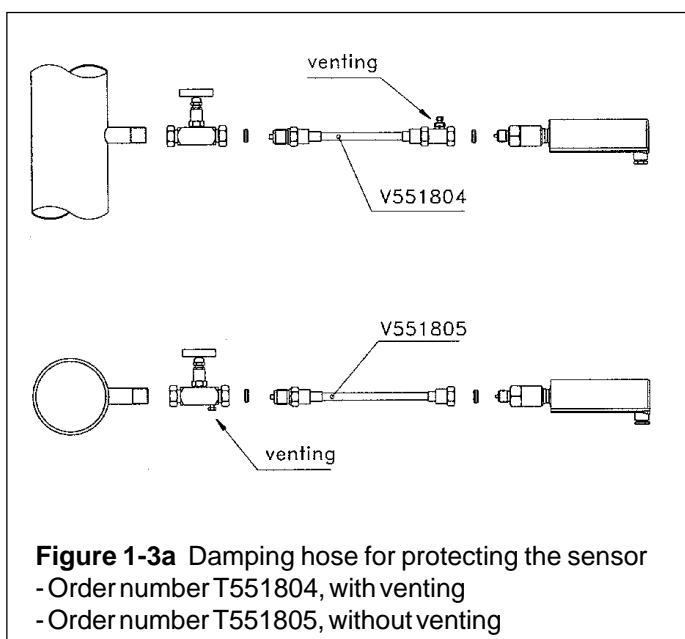
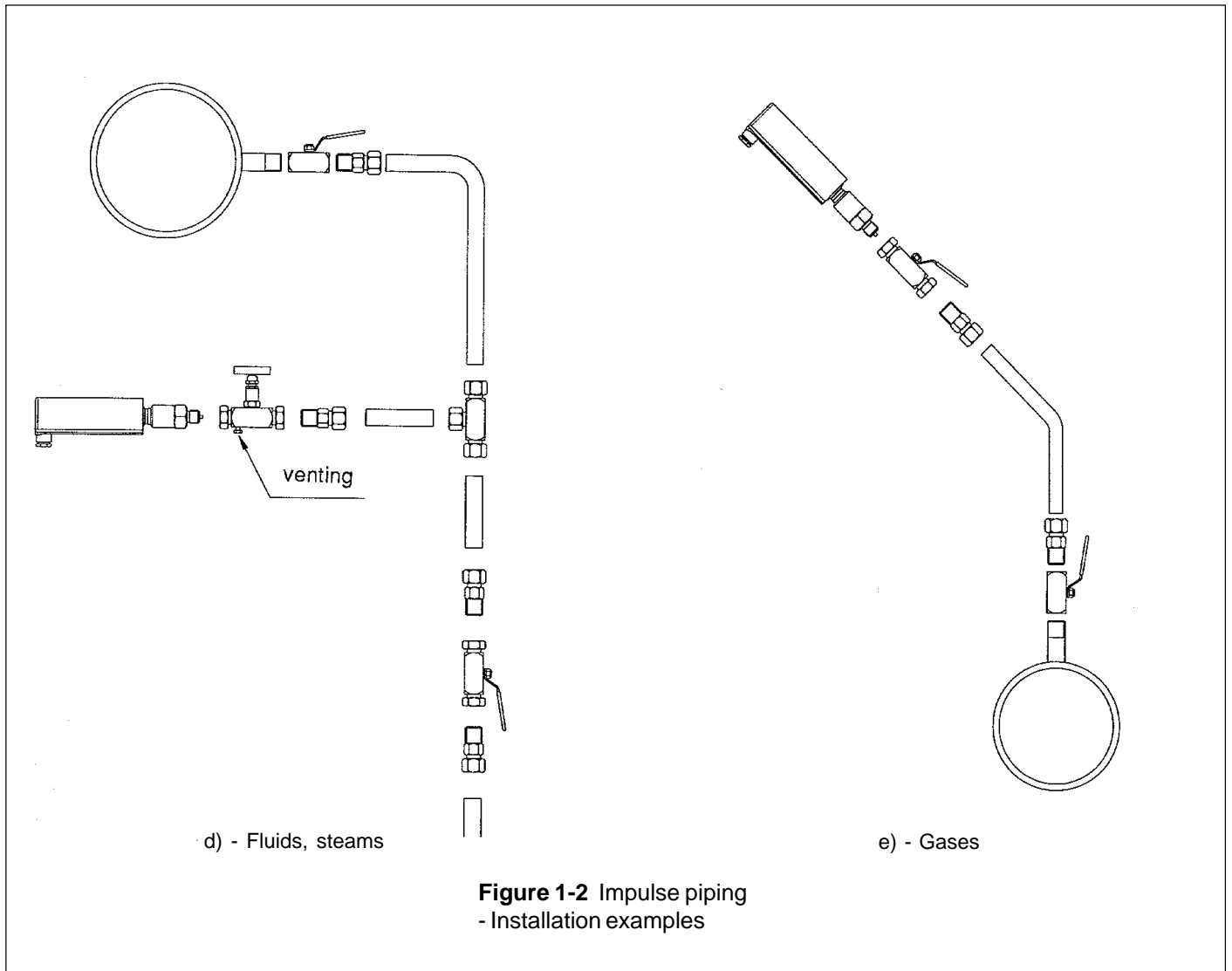

SATRON VT pressure transmitter

1.2 Electrical connections

Supply voltage and load of the transmitter according to the figure 1-5.

We recommend shielded twisted-pair cable as signal cable.

The signal cable should not be installed near high-voltage cables, large motors or frequency converters.

The shield of the cable is grounded at the power supply end or according to the recommendations of the manufacturer of the used control system.

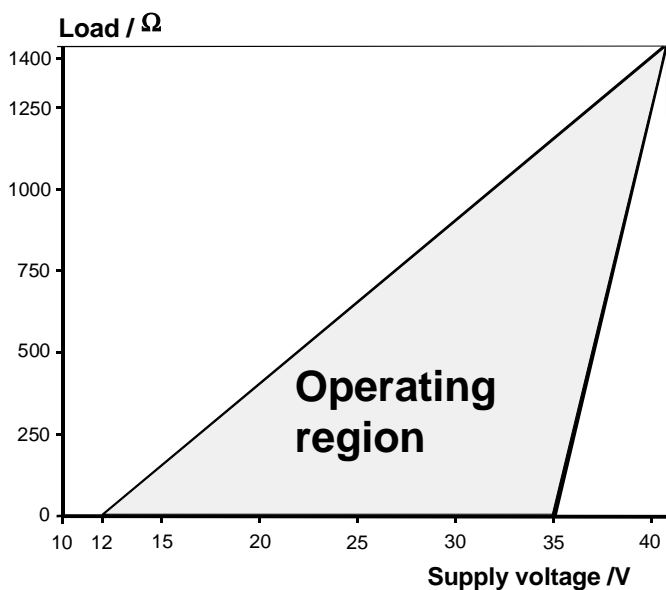
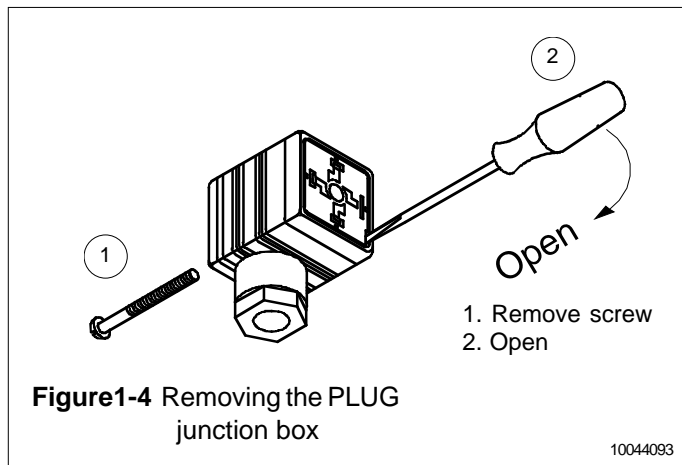

Min. load using HART® - communication 250 Ω

$$R_{max} = \frac{\text{Supply voltage} - 12 \text{ V}}{I_{max}}$$

$I_{max} = 20.5 \text{ mA}$ using HART®-communication

$I_{max} = 23 \text{ mA}$ (when the alarm current 22,5 mA is on)

1300354153

Figure 1-5 Supply voltage and load capacity

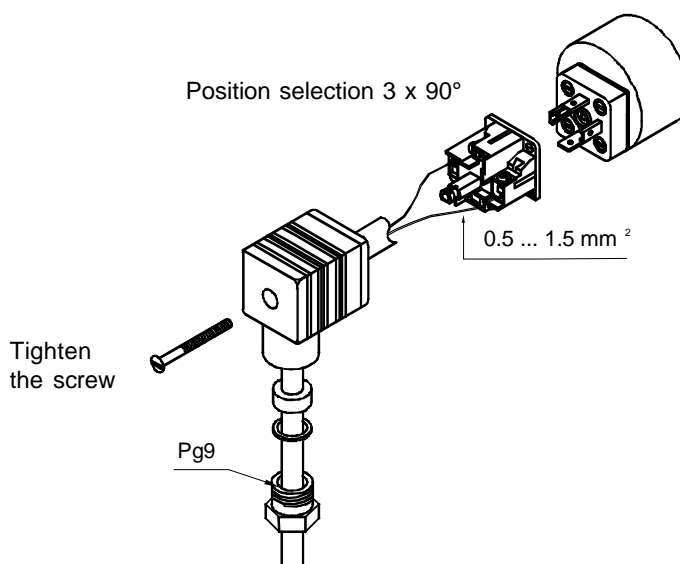
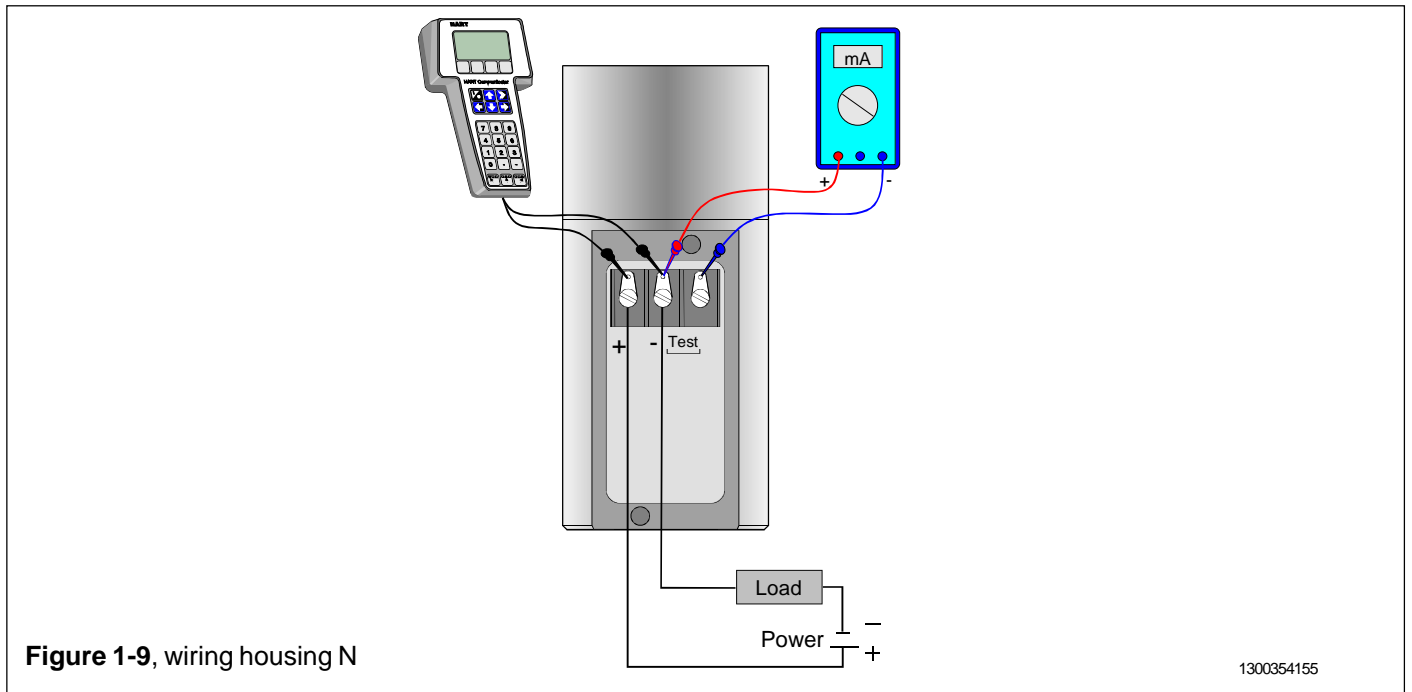
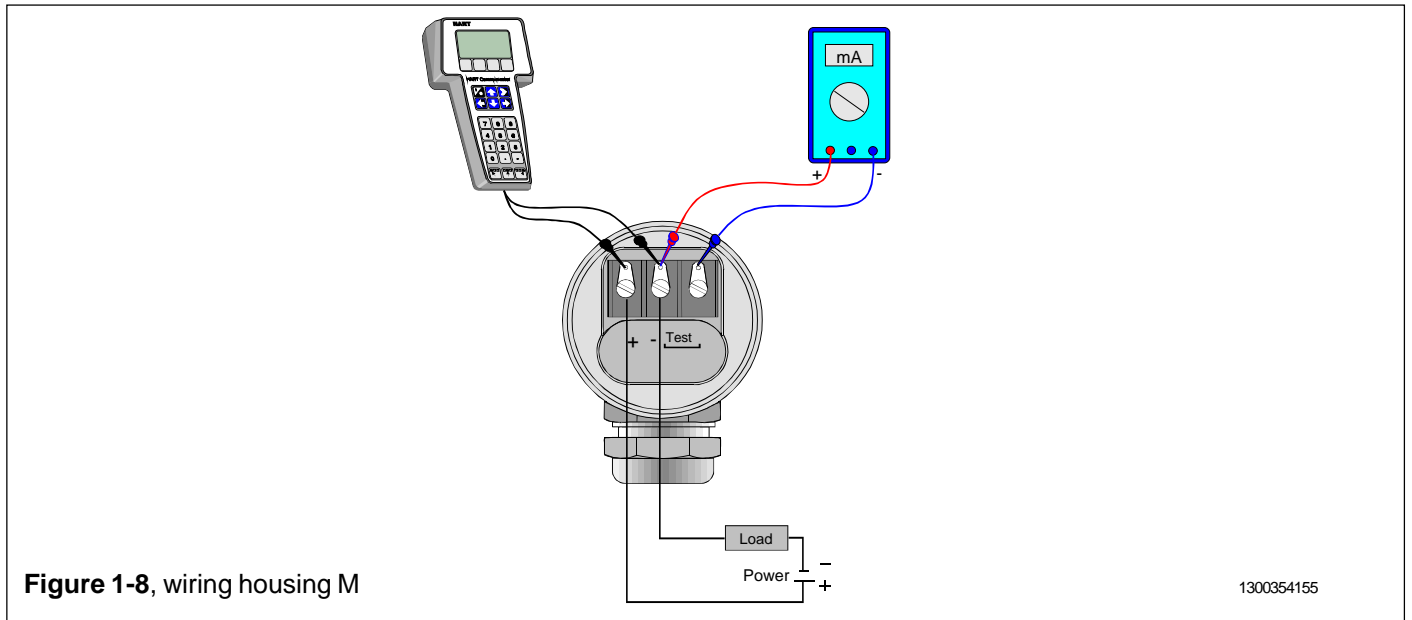
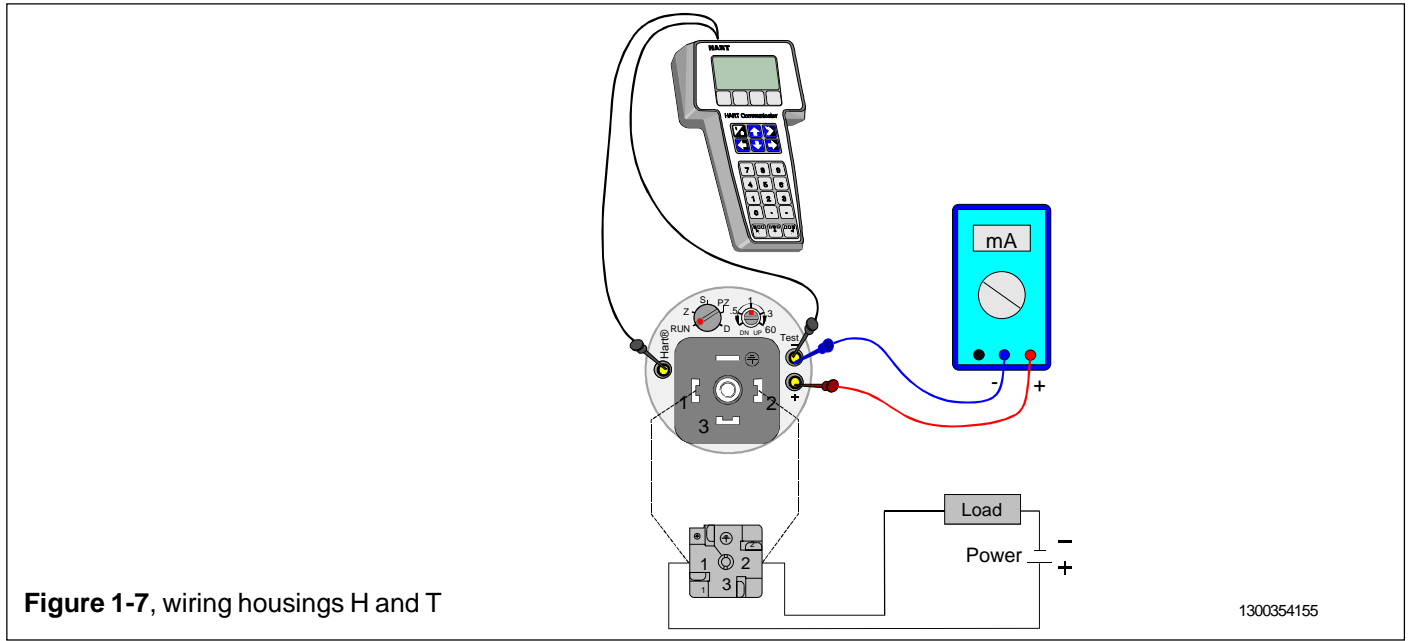

Figure 1-6 Adjusting the junction box position

10044092



2 SETTING UP

2.1 Using the 275 user interface

Operation keys

The six operation keys are located above the alphanumeric keyboard:

The ON/OFF key (**I/O**) switches the user interface on and off. When you switch the user interface on, it starts looking for a HART® transmitter connected to it. If the transmitter is not found, the message **“No Device Found. Press OK”** will be displayed.

The **ONLINE** menu is displayed when the user interface finds the transmitter.

(**^**) This key allows you to move upwards in menus and scroll lists forwards.

(**v**) This key allows you to move downwards in menus and scroll lists backwards.

(**<**) This two-function key allows you to move the cursor to the left and to go back to a previous menu.

(**>**) This two-function key allows you to move the cursor to the right and to select a menu option.

(**>>>**) The quick-selection key will start the user interface and display the quick-selection menu. You can define the desired menu as quick-selection menu.

Function keys

With function keys F1, F2, F3 and F4 you can perform the program functions displayed above each function key. When you move in the software menus, the functions of these keys will change in accordance with the currently selected menu.

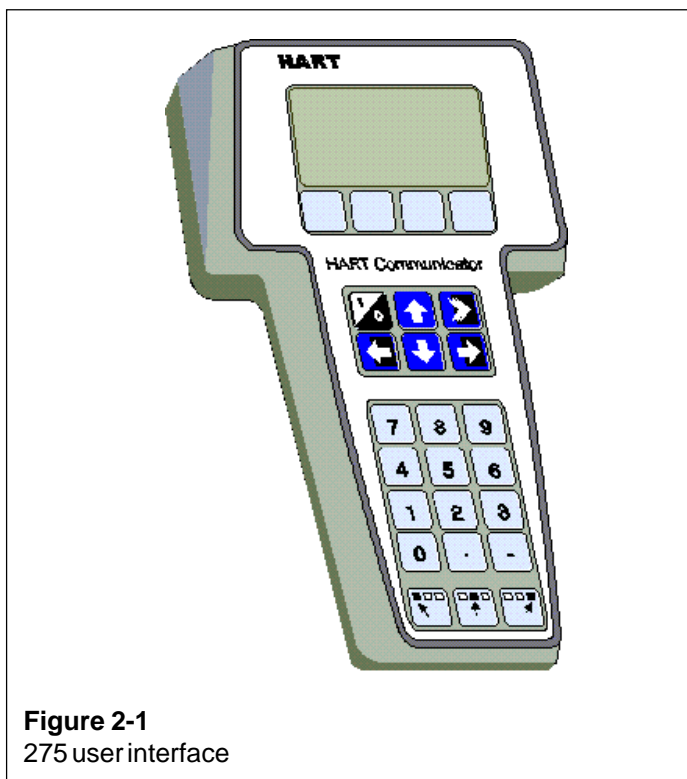

Figure 2-1
275 user interface

2.2 Setting up through HART® 275 user interface

After installing and connecting the transmitter, connect the user interface to the transmitter. The following menu is displayed:

- 1 Measurement
- 2 Configuration
- 3 Information
- 4 Diagnostics

To change the measuring range, unit damping time constant to output mode (linear/square-root), select **Configuration**.

The following menu is then displayed:

- 1 Range values
- 2 Detailed config

To change the measuring range, select **Range values**.

The selection displays the following menu:

- 1 LRV (lower range value)
- 2 URV (upper range value)
- 3 LSL (lower sensor limit)
- 4 USL (upper sensor limit)
- 5 Min span (minimum span)
- 6 Apply values

To change the measurement unit, damping time constant or output mode, select **Detailed config** from the **Configuration** menu.

The selection displays the following menu:

- 1 Damping
- 2 Pres. unit
- 3 Tempr. unit
- 4 Alarm current
- 5 Write protect
- 6 Lin. func
- 7 Diff EI status
- 8 Burst mode
- 9 Burst option
- Poll addr
- Tag
- User function
- User funct. setup

After these activities or if the transmitter is supplied with the ready configuration you must correct a zero error of the transmitter in a final installation position.

Press **Diagnostics** and **PV Zero calibr.**

The selection displays the following menu: **Give correct value for Zero pressure in ...**

The current zero point will be shown in display and the final zero error correction can be done.

2.3 Setting-up with Satron-pAdvisor Service Software

When you will have available all the operations of the Smart transmitter, we recommend the use of Satron-pAdvisor Service Software program in setting-up. Satron Instruments Inc. will deliver you the program, HART-modem and CAL-BOX according the order.

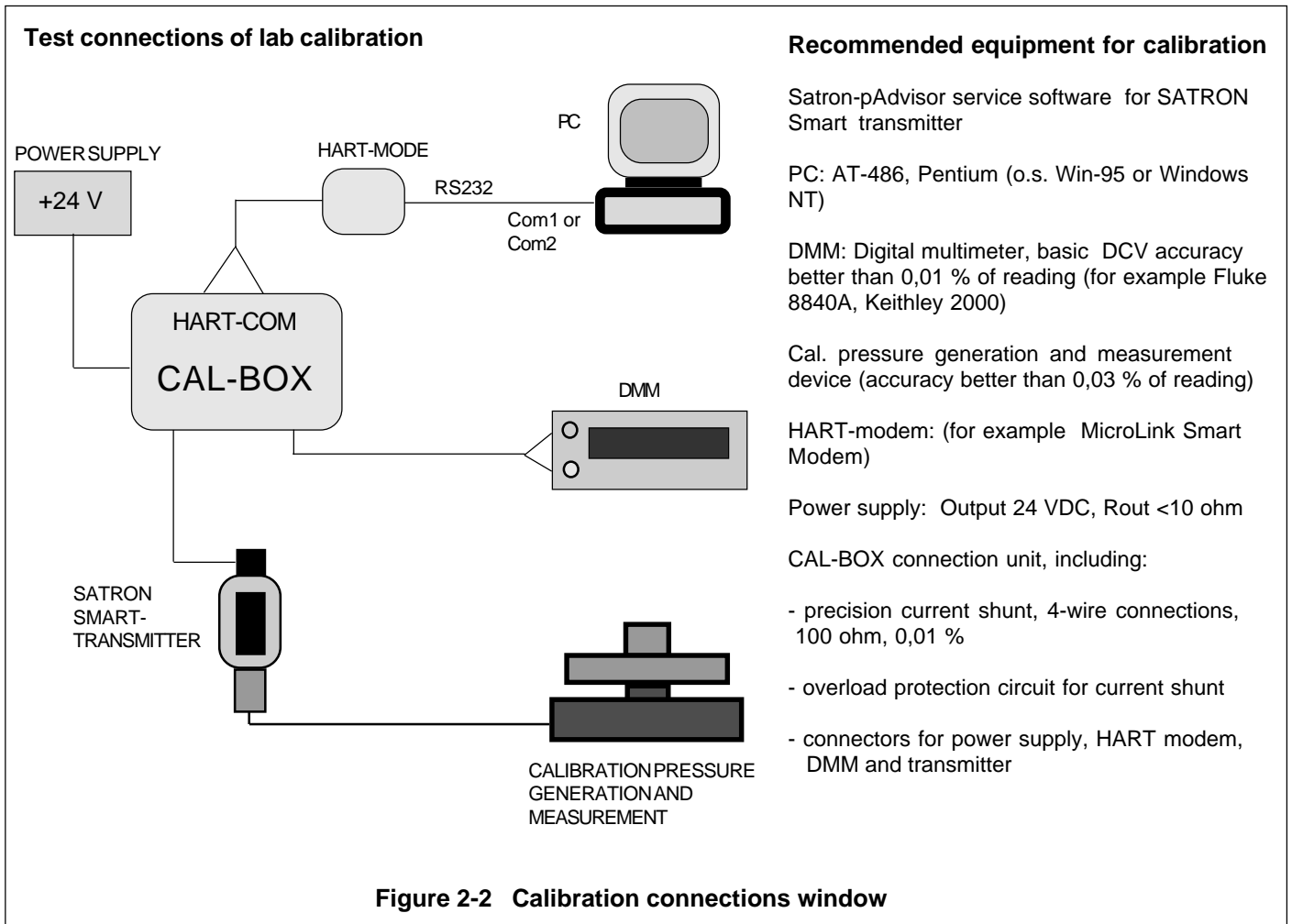

2.4 Setting-up with local switches

The additional instruction of display menus is enclosed to this manual.

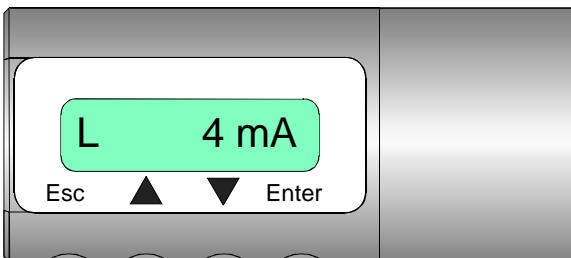

Keyboard :

- Esc = Press **Esc** move back towards the top of the main menu.
- ▲ = Use the **UP** arrow key to move up on the current menu level or to increase the selected parameter value.
- ▼ = Use the **DOWN** arrow key to move down on the current menu level or to decrease the selected parameter value.
- Enter = Press **ENTER** to move to a lower level in a menu or to accept a command or parameter value.

Figure 2-3 VT pressure transmitter with display

275 software tree

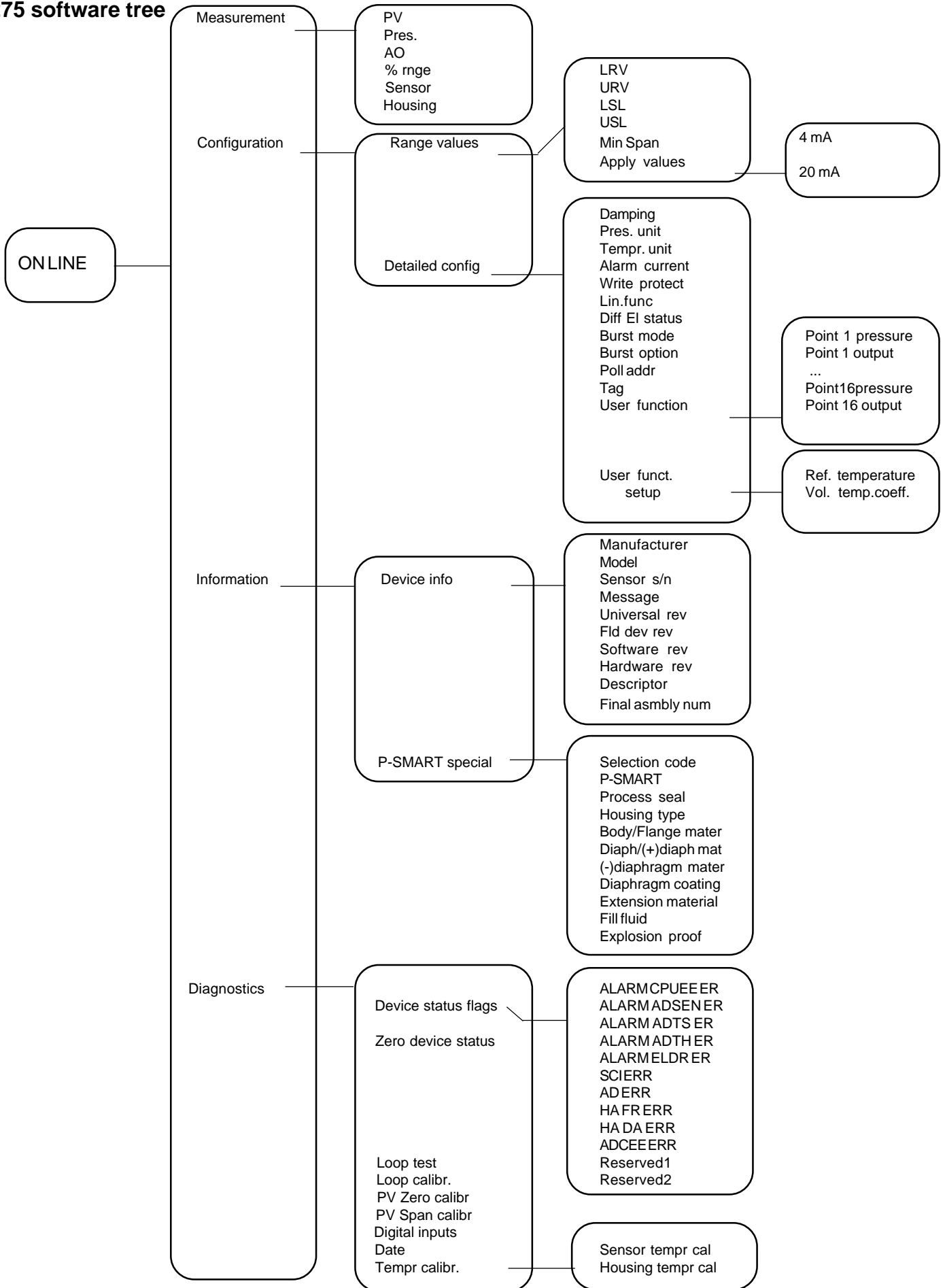

2.5 Set-up calibration, housing code T (with manual adjuster)

The transmitter is factory-calibrated, with 1 sec. electrical damping, for the range specified in the order. If range is not specified, the transmitter will be calibrated for the maximum range.

Zero and Span adjusters are at the end of the housing, under protective rubber shield. TEST jacks are also under protective rubber shield. Figure 2-4: housing T with PLUG connector

Checkout procedure

- See that the ripple on the supply voltage does not exceed $2.5 V_{pp}$ on 0-1000 Hz frequency range.
- Check the nameplate for the factory-calibrated range and zero suppression/elevation.
- If necessary, readjust the zero.

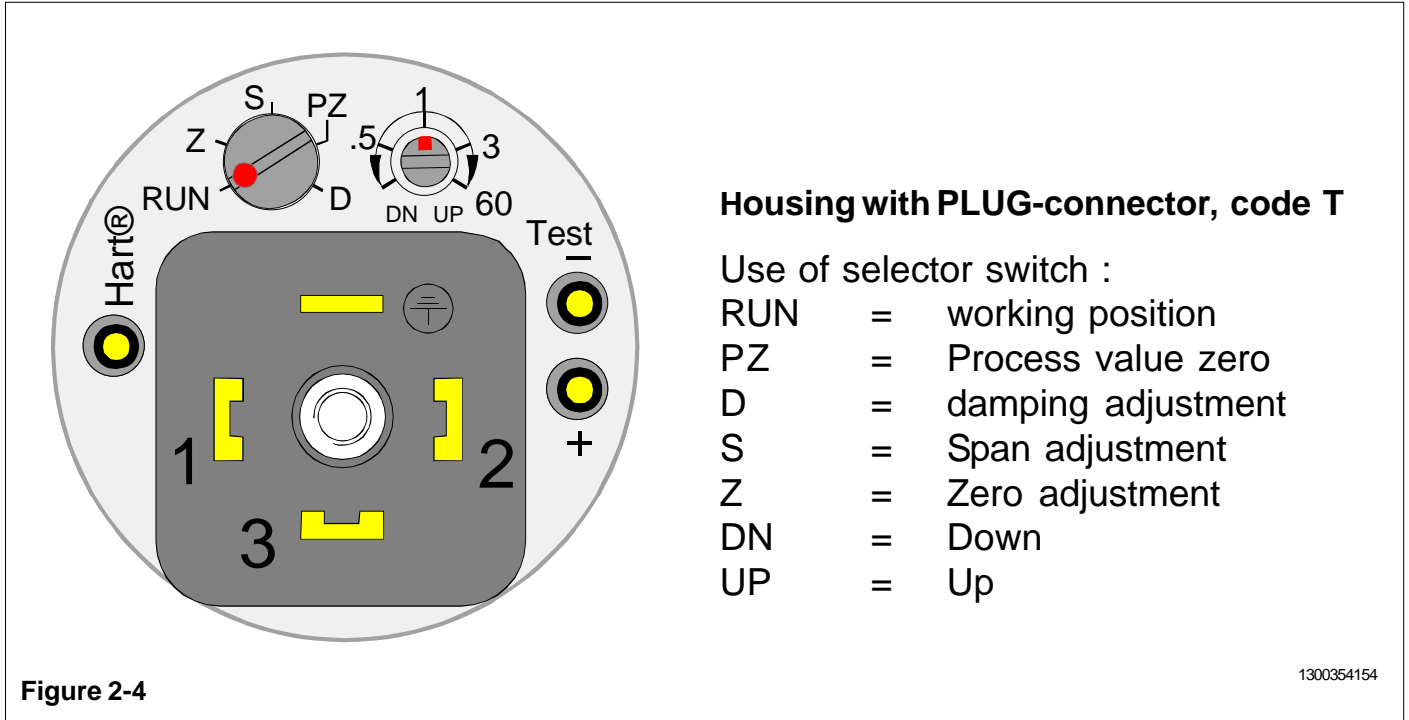

3 CALIBRATION

3.1 Adjustability

Maximum span is 25 times the minimum span for SATRON VT transmitter

Span adjustments is made from outside the housing, under the protective rubber shield (figure 3-1).

Zero suppression and elevation

Maximum zero suppression is 86 % of max.span, and maximum zero elevation is 100 % of max. span. Zero adjustments is made from outside the housing, under the protective rubber shield (figure 3-2).

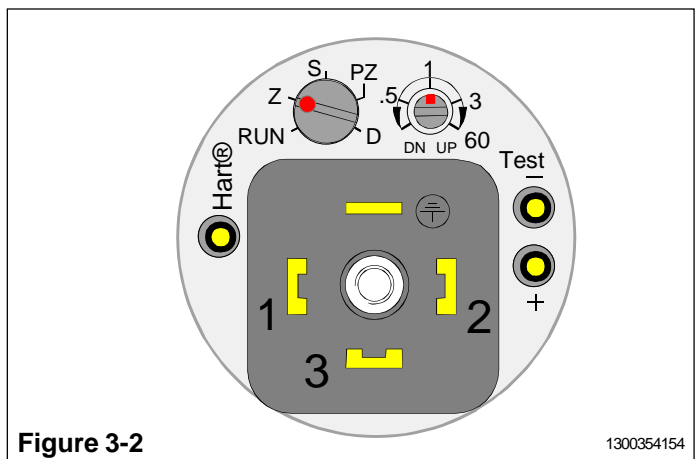
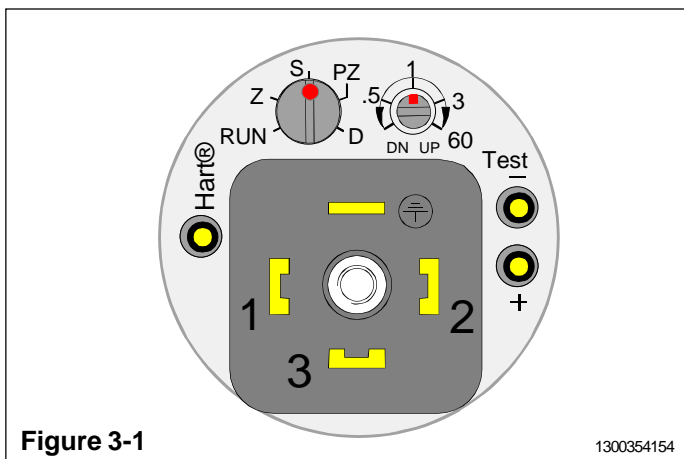

Measuring range

The lower and upper range-values cannot differ from zero by more than the maximum span.

For example, range 5 transmitter whose measuring range is 0-26,5/500 kPa cannot be adjusted to measure 500...526,5 kPa pressure, because maximum span is 500 kPa.

3.2 Damping

If pulsation occurs in the measured pressure, it can be damped with the damping trimmer position D under the protective rubber shield on the housing.

The transmitter is factory-calibrated with minimum electrical damping.

To increase the damping, turn the trimmer clockwise.

Adjusting the damping does not affect the transmitter's other calibration.

Damping adjustment :

1. Turn the selector switch from RUN to position D
2. Turn the regulating switch about $\pm 20^\circ$ so damping adjustment is activated. Turn the regulating switch to desired value of damping. 0 s on the left side, 60 s in the right side.
3. Turn the selector switch from position D to position RUN.

3.3 Calibration examples

First step is process value zero :

1. Turn the selector switch from position RUN to position PZ.
2. PV ZERO is done when the damping trimmer is turned once to both edges at least for 1 sec.
3. Turn the selector switch from position PZ to position RUN.

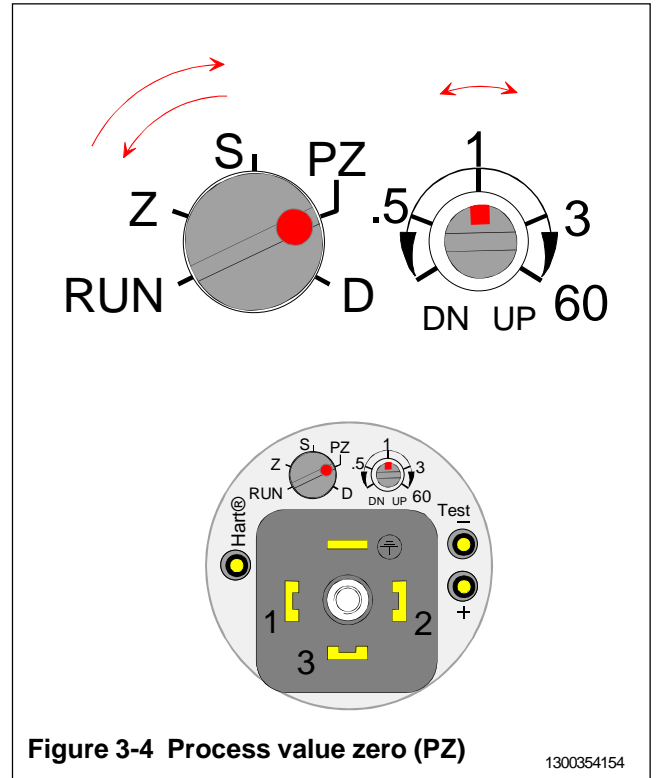

Figure 3-4 Process value zero (PZ)

1300354154

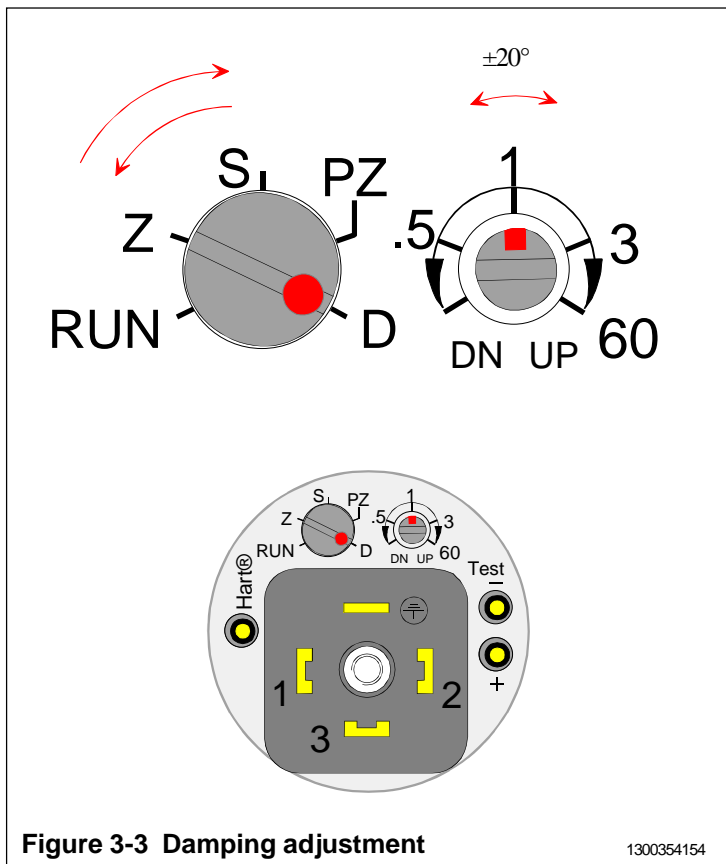

Figure 3-3 Damping adjustment

1300354154

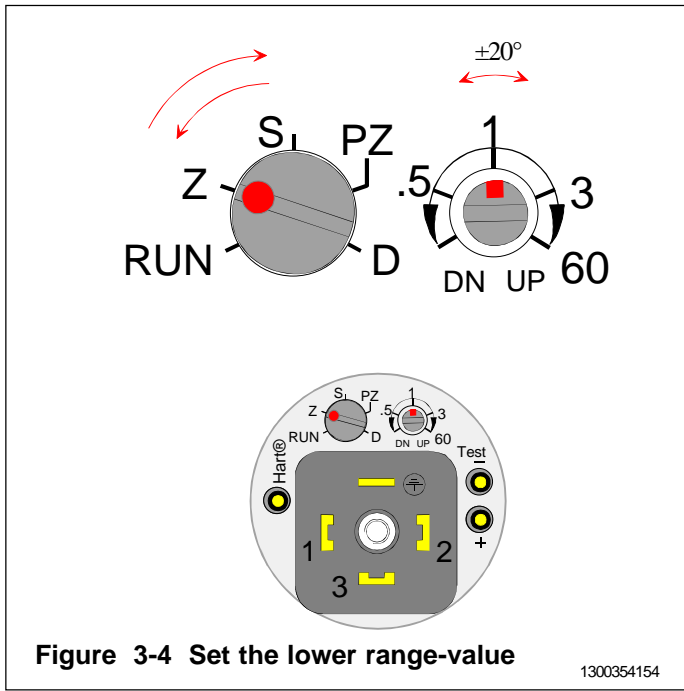

Figure 3-4 Set the lower range-value

1300354154

Measuring range: 0...300 kPa (range 5 transmitter).
Span: 300 kPa

Procedure

- Apply zero pressure.
- 1. Turn the selector switch from position RUN to position Z.
- 2. Turn the regulating switch about $\pm 20^\circ$ so adjustment is activated.
- 3. Turn the regulating switch to a point where output is closest to 4 mA. (adjustment range on fine adjustment range is $\pm 0.75\%$ of span and speed of adjustment is $\pm 2.5\%$ of span / s)
- 4. Turn the selector switch from position Z to position RUN.
- Apply full-span pressure.
- 1. Turn the selector switch from position RUN to position S.
- 2. Turn the regulating switch about $\pm 20^\circ$ so adjustment is activated.
- 3. Turn the regulating switch to a point where output is closest to 20 mA. (adjustment range on fine adjustment range is $\pm 0.75\%$ of span and speed of adjustment is $\pm 2.5\%$ of span / s)
- 4. Turn the selector switch from position S to position RUN.
- Apply zero pressure.
- Repeat the adjustments to achieve the desired accuracy.

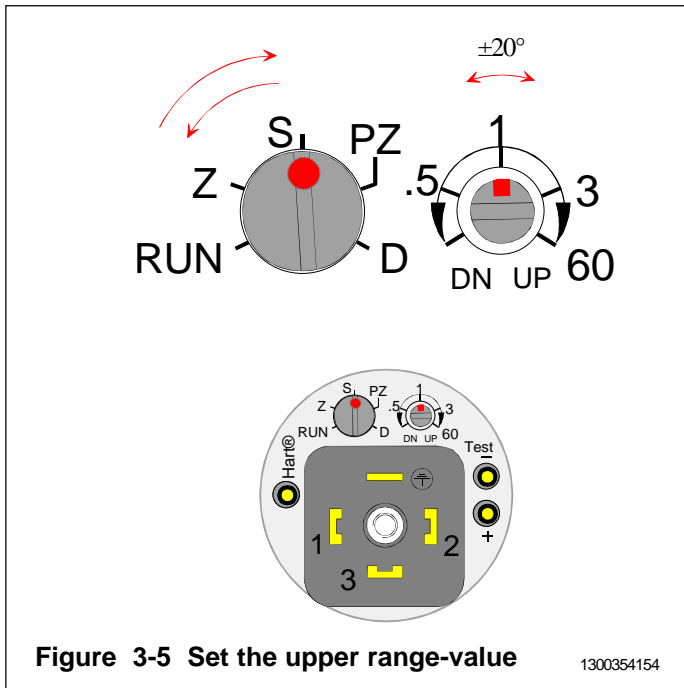

Figure 3-5 Set the upper range-value

1300354154

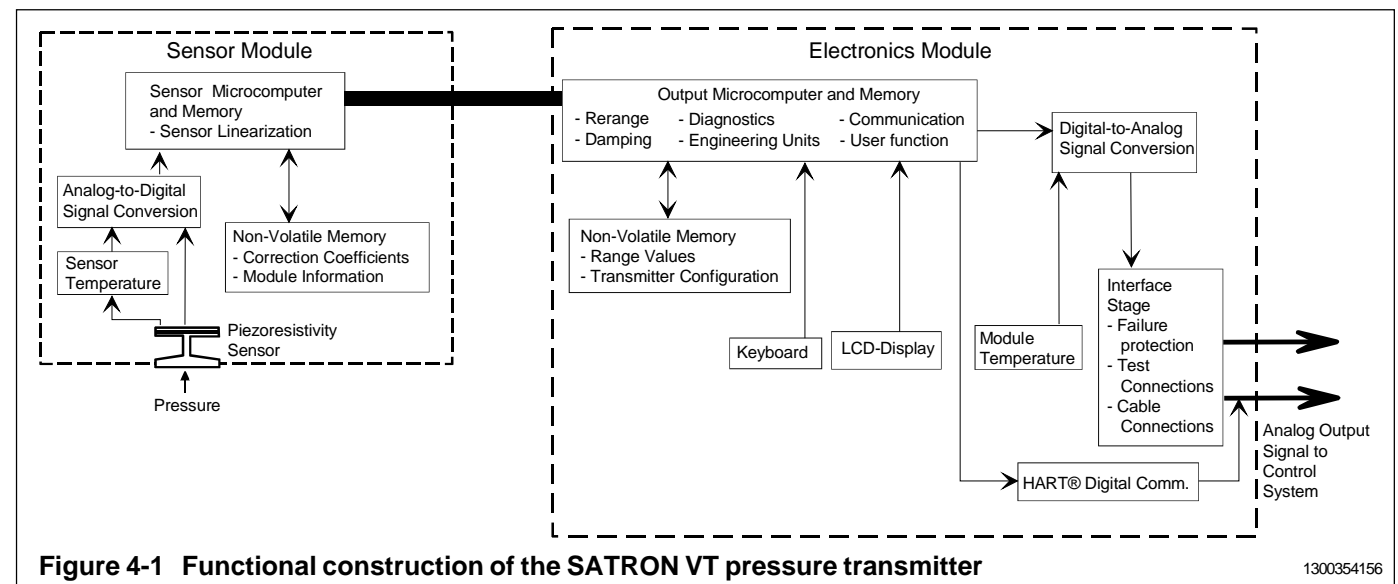

Figure 4-1 Functional construction of the SATRON VT pressure transmitter

1300354156

4. CONSTRUCTION AND OPERATION

4.1 Smart transmitter

Sensor Module

The piezoresistive sensor, which has a silicone oil fill, is isolated from the process with a diaphragm. Sensor pressure and temperature are measured with a 24-bit AD converter. Linearity and temperature effects are digitally corrected with an internal microprocessor connected to the sensor module.

The **sensor** converts pressure to electrical signal. The conversion is carried out through a Wheatstone bridge supplied with direct current. The elastic displacement produced in the bridge by the pressure causes bridge unbalance which is measured as a DC voltage signal.

Compensation includes temperature compensation and linearization. Each sensor is calibrated individually through a resistance network connection. The temperature information required by compensation is derived from a temperature measuring element located by the Wheatstone bridge.

Electronics Module

The electronics module converts the process pressure signal from the sensor module to 4-20 mA output signal. The conversion can be made in linear, square root or inverted mode, or it can be done through user-selectable pressure/output point pairs (2-16 points).

Transmitters provided with own display (code **N**) is equipped with operating keys that allow you to define the transmitter's all functions.

The active functions required for **signal shaping** are in a customized IC which is divided into two sub-blocks: amplifier block and standard-signal shaping block. The standard-signal shaping block also includes zero, span and damping adjustments.

The **interface stage** includes failure protections to ensure the transmitter's operation and nonfailure in possible failure conditions. This stage also includes the TEST and cable connections

5. PARTS LIST

When ordering spares, please quote this document's number BPH710AV and date 2004-07-31, the name and order number of the required part, and the transmitter's serial number. Parts indicated with asterisk (*) as well as screws, nuts and seals (packings) are spare parts.

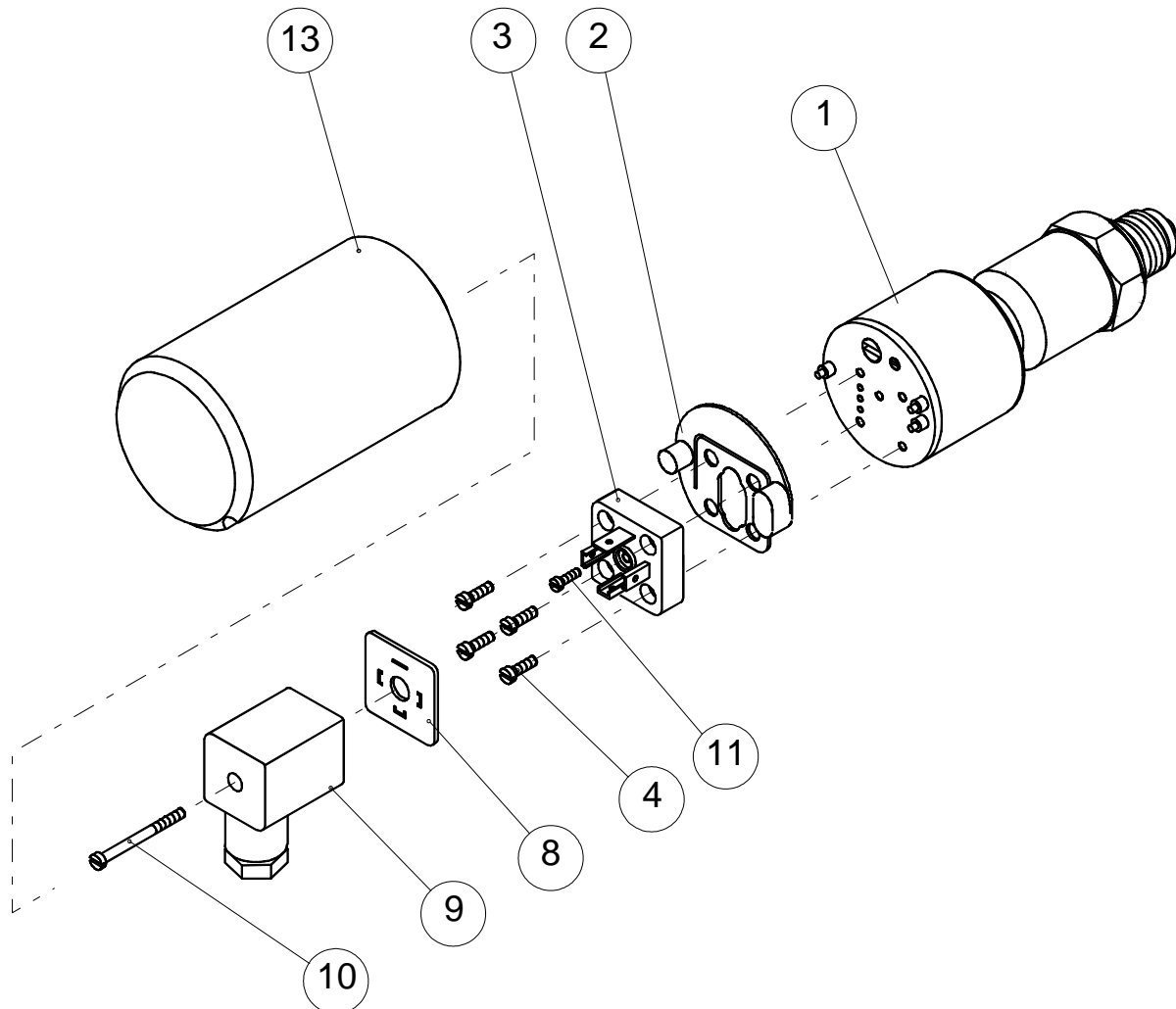
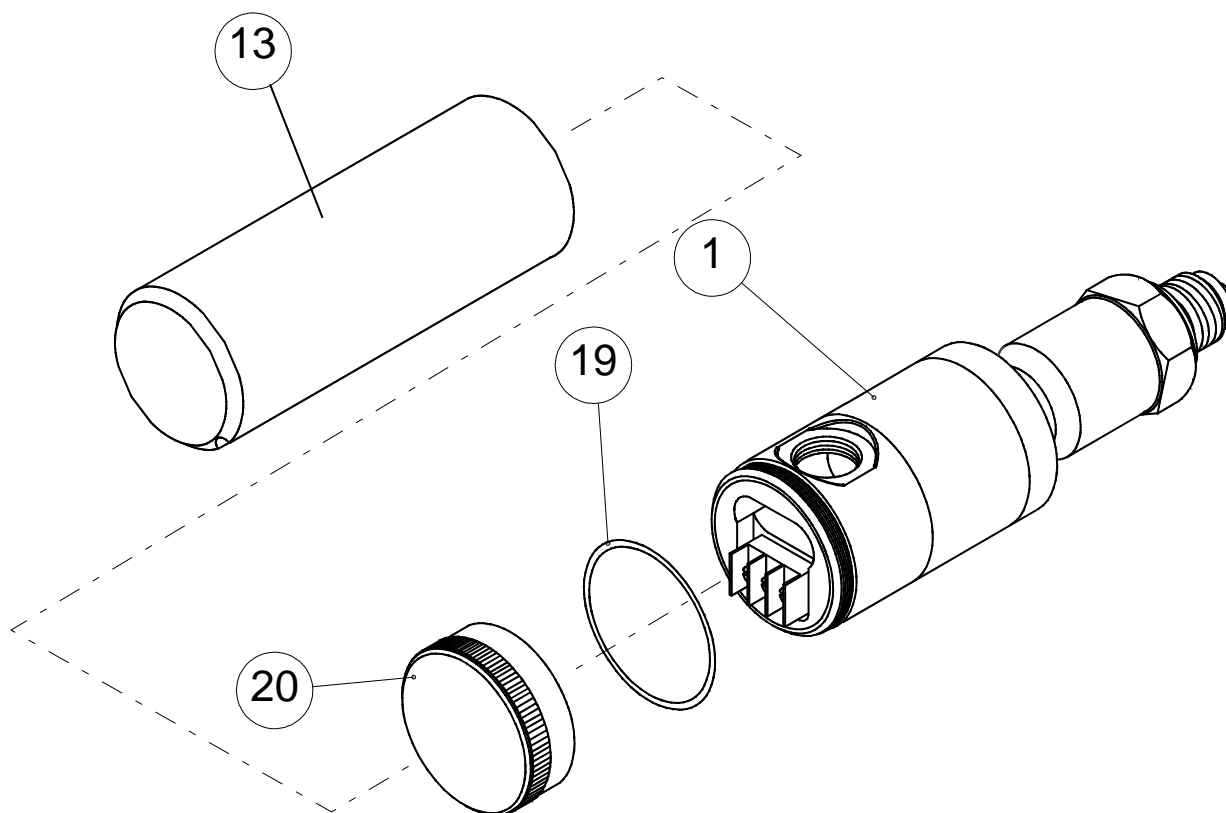

Figure 5-1 Parts list: Enclosures H and T, housing with PLUG connector



1300354161

Figure 5-2 Parts list:
Enclosure M, housing with terminal board

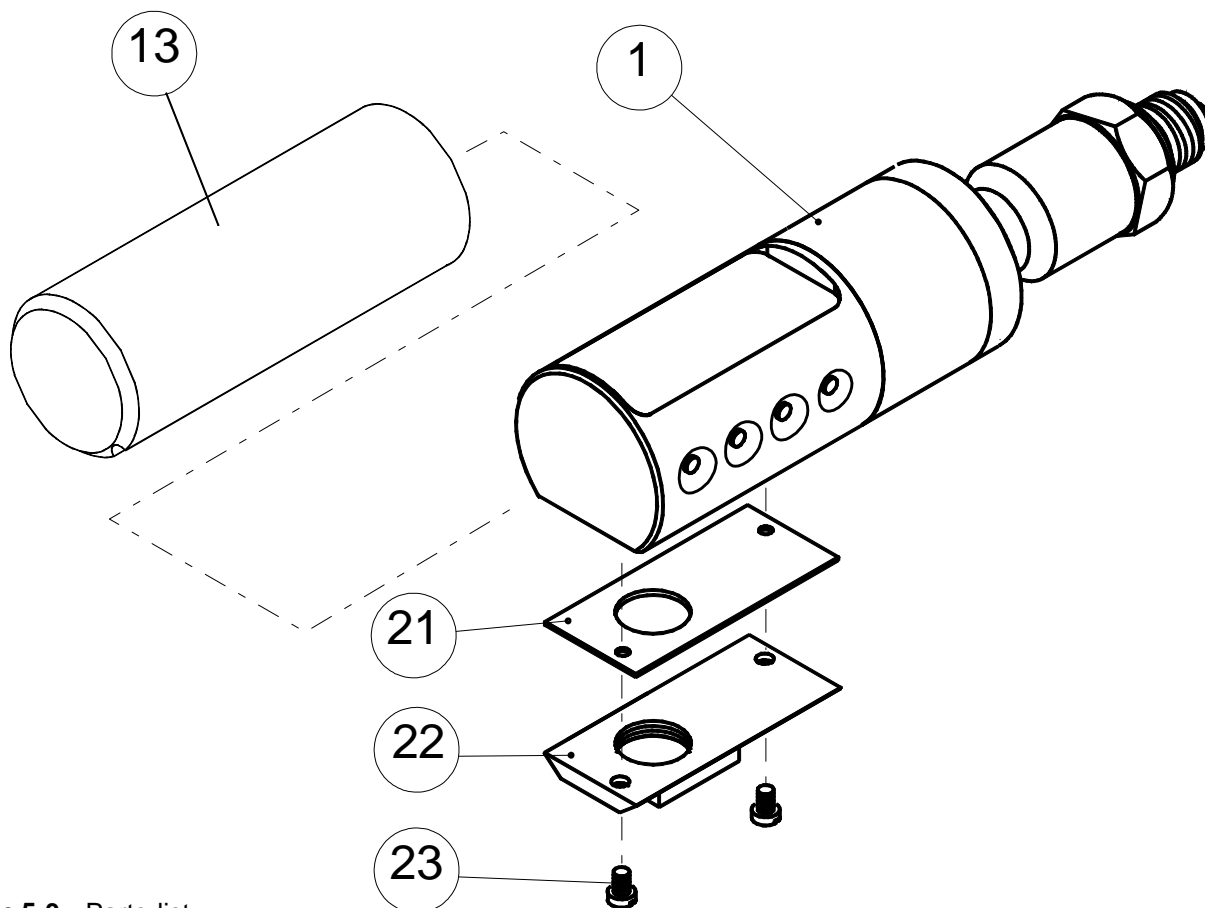

Figure 5-3 Parts list:
Enclosure N, housing with display

1300354162

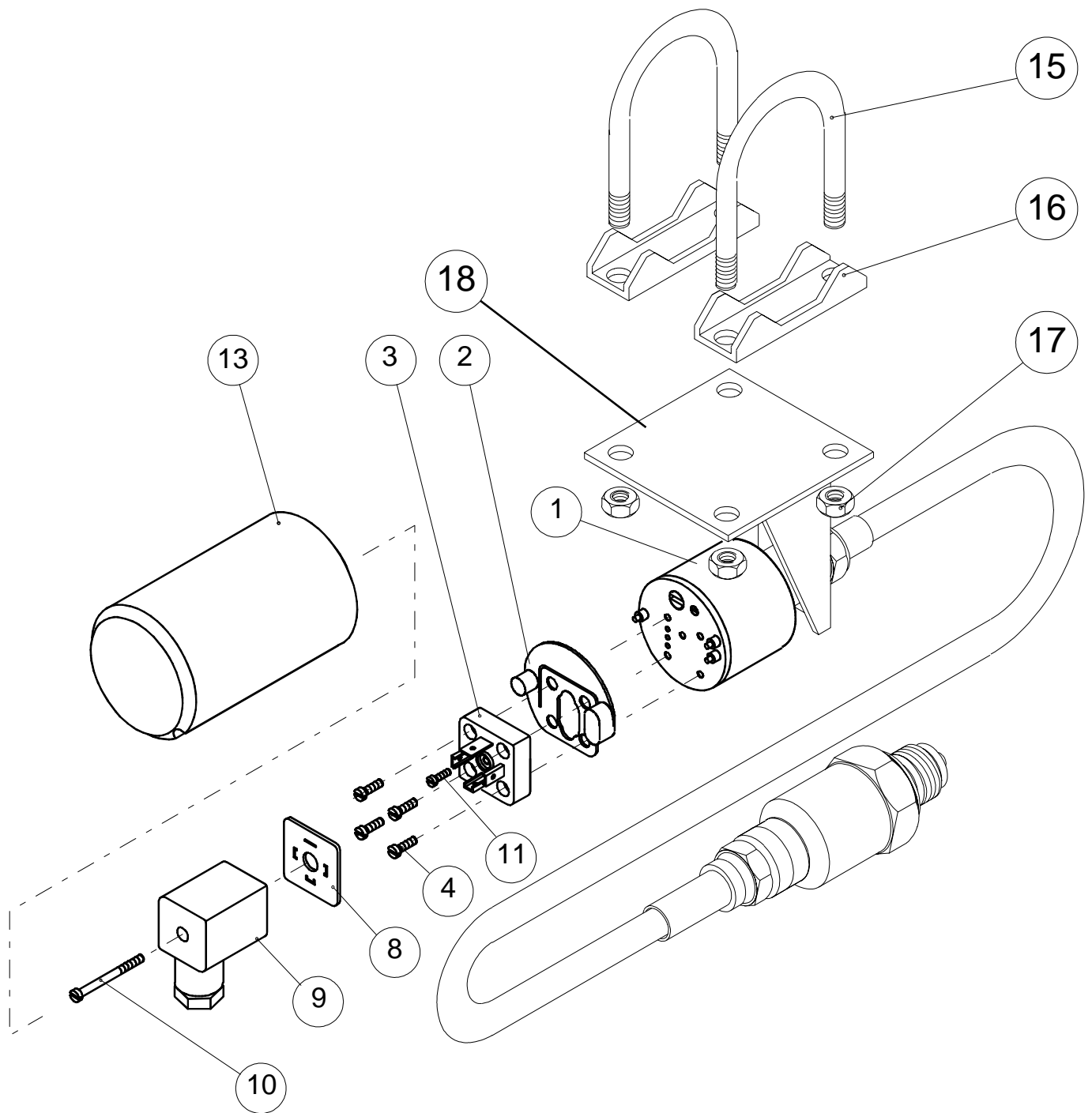

Figure 5-4 Parts list:
Enclosure with remote electronics

1300354162

Number	Name	Order number	Number	Name	Order number
1	Sensing element		* 15	Mounting clamp	T544953
2	Seal	T1300207	* 16	Support plate	T543223
* 3	Device plug DIN43650	72900114	17	Hex nut	56022800
4	Cylinder-head screw M3 x 10 SFS2179 Zne	51603021		M8 SFS2067 A4	
8	Seal GDM3-17,silicone	72900116	* 18	Mounting bracket S	T1050009
* 9	Wiring box GDM3009, DIN43650	72900111	19	O-ring, 42x2 FPM (Viton®)	80013800
10	Cylinder-head screw S M3 x 35 SFS2179 A4	51723053	* 20	Cover M	T1300256
11	Cylinder-head screw S M3 x 4 VSM 13302 Zne	51613009	21	Seal N, Silicone rubber	T1300262
* 13	Protection cup, housing H, M and T	T1300295	* 22	Cover N	T1300260
* 13	Protection cup, housing N	T1300296	23	Cylinder-head screw S M4x8 SFS2176 A4	51624012



MEETS THE COUNCIL OF THE EUROPEAN UNION DIRECTIVE
89/336/EEC FOR ELECTROMAGNETIC COMPATIBILITY
REQUIREMENTS.



Satron Instruments Inc.

P.O.Box 22, FIN-33901 Tampere, Finland
Tel.int. +358 207 464 800, Telefax +358 207 464 801