



# DPT145 Multiparameter Transmitter

For SF<sub>6</sub> gas



Vaisala Multiparameter Transmitter DPT145 with DILO DN20 connector

## Features

- The first transmitter to offer online measurement of seven SF<sub>6</sub> parameters in one unit
- Measured parameters: dew point, pressure, temperature
- Calculated parameters: SF<sub>6</sub> density, normalized pressure, dew point in atmospheric pressure, ppm
- More reliable assessment of the condition of SF<sub>6</sub> insulation due to online measurement
- Digital output: RS-485 with Modbus®
- Long calibration interval of years

Vaisala Multiparameter Transmitter DPT145 for SF<sub>6</sub> gas is a unique innovation that enables online measurement of dew point, pressure, and temperature. It also calculates four other values, including SF<sub>6</sub> density. DPT145 is especially well suited for integration into OEM systems.

### Online reliability

Online dew point measurement combined with pressure measurement provides an excellent assessment of the condition of SF<sub>6</sub> insulation. Sudden and minor leakages are immediately detected by the direct normalized pressure measurement, while online dew point measurement alerts the user to moisture issues, which can weaken the insulation properties of SF<sub>6</sub> and cause rapid deterioration. With DPT145, it is also easy to build a redundant solution for multiple parameters.

### Savings across the board

A single transmitter, instead of several, saves time and money across the board, from investment to installation, operation, and servicing. Lower assembly

costs, fewer cables and connectors, minimized need for on-site visits and field operations - all these translate into cumulative savings. The long calibration interval results in further savings.

### Risk-free, greener solution

Online measurement enables gas trends to be followed via a data collection system, making monitoring fast, risk-free, and accurate. Using one instrument for monitoring seven different parameters means also fewer mechanical connections and reduces the risk of leaks. Monitoring is environmentally friendly because there is no need for sampling - no SF<sub>6</sub> gas is released into the atmosphere.



DPT145 with weather shield

### The fruit of experience

Vaisala has over 80 years of extensive measurement experience and knowledge. DPT145 brings together the proven DRYCAP® dew point sensor technology and BAROCAP® pressure sensor technology in one package, providing an innovative and convenient solution for monitoring SF<sub>6</sub> gas.

# Technical data

## Measured parameters

Dew point	-60 ... +30 °C (-76 ... +86 °F)
Pressure, absolute	1 ... 12 bar (14.5 ... 174 psi)
Temperature	-40 ... +80 °C (-40 ... +176 °F)

## Calculated parameters

Pressure, normalized to +20 °C (+68 °F)	1 ... 12 bar (14.5 ... 174 psi)
SF <sub>6</sub> or SF <sub>6</sub> /N <sub>2</sub> mixture density	0 ... 100 kg/m <sup>3</sup>
Moisture by volume, ppm	40 ... 40 000 ppm
Dew point, converted to atmospheric pressure	-65 ... +30 °C (-85 ... +86 °F)

## Measurement performance

Dew point accuracy	±3 °C (±5.4 °F), see graph below
Dew point stability	Typical drift < 2 °C (3.6 °F) / 5 years
Pressure accuracy at +23 °C (+73.4 °F)	±0.4 %FS
Pressure temperature dependence	±0.01 bar/10 °C (18 °F)
Pressure stability	Typical drift < 1 %FS / 5 years
Temperature accuracy	0 ... +40 °C (+32 ... +104 °F): ±0.5 °C (± 0.9 °F) -40 ... 80 °C (-40 ... +176 °F): ±1 °C (± 1.8 °F)
Density accuracy (pure SF <sub>6</sub> , 1 ... 12 bara)	0 ... +40 °C (+32 ... +104 °F): ±1 %FS -40 ... +60 °C (-40 ... +140 °F): ±2.2 %FS
Typical ppm accuracy (5 ... 1000 ppm, 7 bar)	±(7 ppm + 15 % of reading)
Sensor	Vaisala MPS1 multiparameter sensor

### Sensor response time

Pressure response time	< 1 s
Dew point response time <sup>1)</sup> 63 % [90 %] at 20 °C and 1 bar	-50 → -10 °C Tdf: 5 s [10 s] -10 → -50 °C Tdf: 10 s [2.5 min]

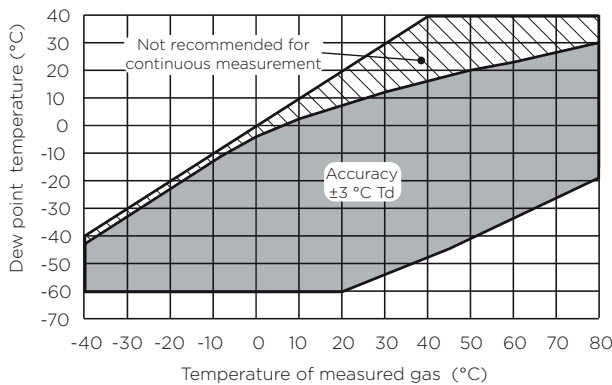

DPT145 dew point measurement accuracy

<sup>1)</sup> System equilibrium related response time is typically longer.

## Inputs and outputs

Digital outputs	RS-485, non-isolated, Vaisala protocol Modbus RTU protocol
Connector	M8 4-pin male
Operating voltage	15 ... 28 VDC 20 ... 28 VDC in cold temperatures (-40 ... -20 °C (-40 ... -4 °F))
Supply current, during normal measurement	20 mA
Supply current, during self-diagnostics	Max. 300 mA pulsed

## Operating environment

Operating temperature of electronics	-40 ... +60 °C (-40 ... +140 °F)
Operating pressure	1 ... 12 bar (14.5 ... 174 psi)
Mechanical durability	0 ... 50 bar (0 ... 725 psi)
Relative humidity	0 ... 100 %
Measured gases	SF <sub>6</sub> , SF <sub>6</sub> /N <sub>2</sub> mixture
Storage temperature, transmitter only	-40 ... +80 °C (-40 ... +176 °F)
Storage temperature, shipment package	-20 ... +80 °C (-4 ... +176 °F)

## Mechanical specifications

Housing material	AISI316L
Mechanical connection	DILO DN20, DILO DN8, ABB Malmquist, or Alstom G1/2" compatible connector Every connection is helium leak tested at the factory.
Weight (with DILO adapter)	765 g (27.0 oz)
IP rating	IP66 <sup>1)</sup>

<sup>1)</sup> Weather shield to be used in continuous outdoor installations.

## Compliance

EMC compatibility	EN 61326-1, basic electromagnetic environment
Compliance marks	CE, RCM, WEEE
<b>Mechanical vibration</b>	
Vibration (sinusoidal) IEC 60068-2-6	±6 g, 5-500 Hz sweep 60 min/axis, 3-axis

## Spare parts and accessories

Connection cable for the MI70/DM70 handheld	219980
USB connection cable	219690
Protection plug for connector	218675SP
1.5 m shielded PUR cable with 90° connector	231519SP
3 m shielded PUR cable with 90° connector	231520SP
5 m shielded PUR cable with 90° connector	231521SP
10 m shielded PUR cable with 90° connector	231522SP
3 m shielded FEP cable with straight connector	226902SP
Weather shield	ASM210326SP

# Technical data

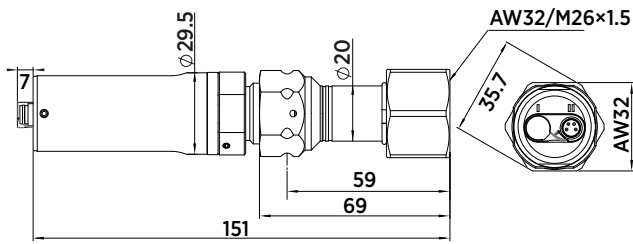

DPT145 with DILO DN8 connector

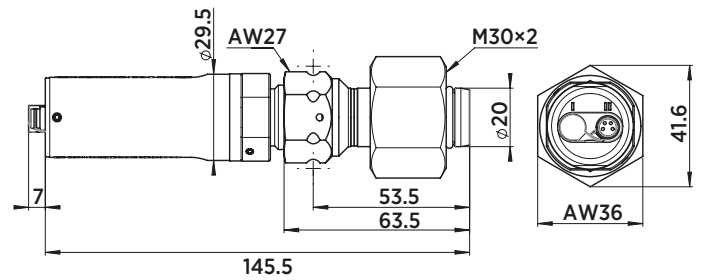

DPT145 with ABB Malmquist connector

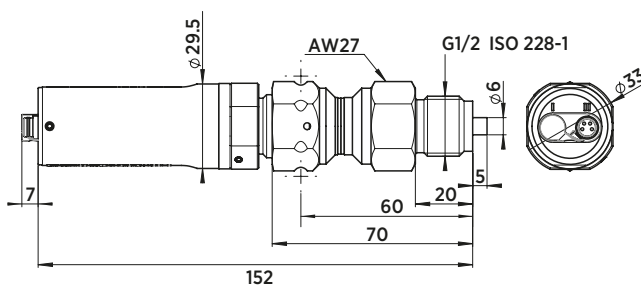

DPT145 with Alstom connector

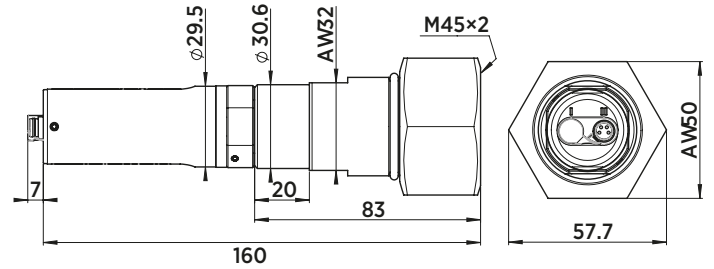

DPT145 with DILO DN20 connector

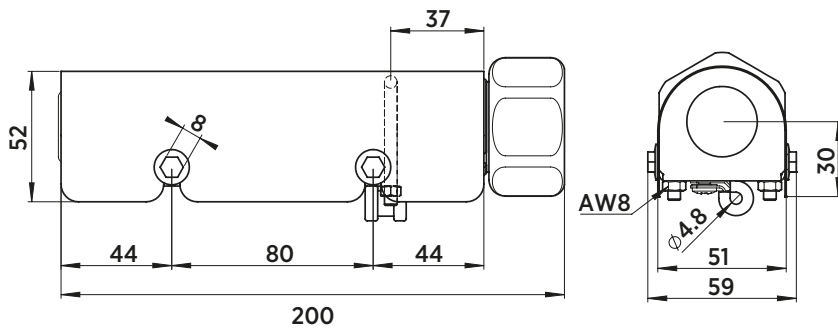

DPT145 with weather shield

mm