



HMD110/112 and HMW110/112 Humidity and Temperature Transmitters

For high-accuracy measurements
in HVAC applications



Features

- Accurate humidity and temperature transmitters for measurements in HVAC applications
- Proven Vaisala HUMICAP® 180R humidity sensor for superior long-term stability
- ± 2 %RH accuracy
- 3-point traceable calibration (%RH), 1-point traceable calibration (T), certificate included
- Analog (4 ... 20 mA) and Modbus® RTU output options

The high-accuracy transmitters HMD110/112 and HMW110/112 are designed for measuring humidity and temperature in HVAC applications. Calculated humidity parameters are also conveniently available, including dew point temperature, wet bulb temperature, and enthalpy. The measurement is highly accurate to enable precise and reliable control of HVAC systems.

The transmitters belong to Vaisala HUMICAP® Humidity and Temperature Transmitter Series HMDW110, which includes transmitters for duct mounting, IP65-rated wall transmitters, immersion temperature transmitters, and outdoor transmitters with integrated radiation shields. Transmitter models with display will be available in H2/2022.

Highly accurate, proven Vaisala HUMICAP performance

The highly accurate HMD110/112 and HMW110/112 transmitters are designed for measuring humidity and temperature in various HVAC applications. The high accuracy and reliability of the measurement enable precise and reliable controls of HVAC systems.

The transmitters are equipped with the trusted HUMICAP 180R humidity sensor, which is the robust sensor designed for industrial applications. The sensor's superior long-term stability allows for unbeatable long-term accuracy of the instrument and minimizes maintenance needs throughout the transmitter's lifetime.

Optional output parameters include dew point temperature, wet bulb temperature, and enthalpy, which are selectable with Vaisala Insight PC software.

Excellent choice for challenging conditions

The IP65-rated HMD110/112 and HMW110/112 transmitters are optimal for even challenging conditions, such as cleanrooms, data centers and other

industrial settings. The transmitters can also be ordered with the catalytic HUMICAP 180V humidity sensor. The catalytic sensor improves stability especially in hydrogen peroxide sterilized environments where repeated condensation can be expected.

Traceable accuracy

The instruments are individually adjusted and delivered with a traceable (ISO 9001) calibration certificate. If required later on, the transmitter can be easily field-calibrated using Vaisala Handheld Humidity and Temperature Meter HM70 or Vaisala Insight PC software.

Technical data



HMD110/112 RH+T transmitters for ducts

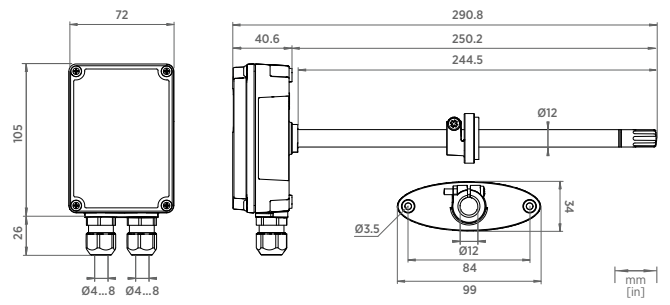

Dimensions in mm



HMW110/112 wall-mount RH+T transmitters with IP65 rating

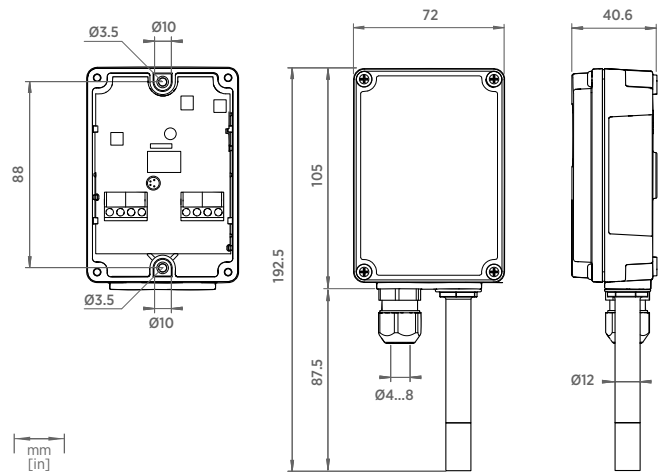

Dimensions in mm

Models

Model	Type	Output	Special features
HMW110	Wall-mount, RH+T	2-wire current or Modbus RTU output	Configurable model ¹⁾ Optional display ²⁾
HMW112	Wall-mount, RH+T	2-wire current output	
HMD110	Duct-mount, RH+T	2-wire current or Modbus RTU output	Configurable model ¹⁾ Optional display ²⁾
HMD112	Duct-mount, RH+T	2-wire current output	

- 1) Delivered with customer specific output settings, including calculated humidity parameters and custom scaling of outputs.
2) Display models available from H2/2022.

Measurement performance

Relative humidity

Measurement range	0 ... 100 %RH
Accuracy: ¹⁾	
at +10 ... +30 °C (+50 ... +86 °F)	±2 %RH (0 ... 90 %RH) ±3 %RH (90 ... 100 %RH)
at -20 ... +10 °C, +30 ... +60 °C (-4 ... +50 °F, +86 ... +140 °F)	±3 %RH (0 ... 90 %RH) ±4 %RH (90 ... 100 %RH)
at -40 ... -20 °C (-40 ... -4 °F)	±4 %RH (0 ... 100 %RH)
Stability in typical HVAC applications	±0.5 %RH/year
Humidity sensor types	HUMICAP® 180R HUMICAP® 180V

Temperature

Measurement range	-40 ... +60 °C (-40 ... +140 °F)
Accuracy at +20 °C (+68 °F)	±0.2 °C (±0.36 °F)
Temperature dependence	±0.01 °C/°C
Temperature sensor	Pt1000 RTD Class F0.1 IEC 60751
Factory calibration uncertainty at +20 °C (+68 °F)	±1.5 %RH/±0.2 °C

- 1) With HUMICAP® 180V humidity sensor, accuracy is not specified below -20 °C (-4 °F) operating temperature.

Calculated parameters

Measurement range

Dew point temperature and wet bulb temperature	-40 ... +80 °C (-40 ... +176 °F)
Enthalpy	-40 ... 1530 kJ/kg (-9.6 ... 648 BTU/lb)

Accuracy ^{1) 2)}

Dew point	±0.7 °C (1.2 °F)
Wet bulb temperature	±0.5 °C (0.9 °F)
Enthalpy	±1.6 kJ/kg (0.7 BTU/lb)

- 1) At +20 °C (+68 °F) and 80 %RH.
2) Accuracy of the calculated parameters should be calculated at the actual condition based on the RH and temperature specification.

Mechanical specifications

Screw terminal wire size	Max. 1.5 mm ² (AWG 16)
Standard housing color	White (RAL9003)
Housing material	PC + 10 %GF (UL-V0 approved)

Inputs and outputs

Devices ordered with analog output

Outputs	4 ... 20 mA, loop powered
Loop resistance	0 ... 600 Ω
Supply voltage	20 ... 28 V DC at 600 Ω load 10 ... 28 V DC at 0 Ω load

Devices ordered with Modbus output

Interface	RS-485, not isolated, no line termination
Default serial settings	19200 bps N 8 2
Protocols	Modbus® RTU
Supply voltage	10 ... 28 V DC

Operating environment

Operating temperature:

with display	-5 ... +60 °C (+23 ... +140 °F)
without display	-40 ... +60 °C (-40 ... +140 °F)

Operating humidity	0 ... 100 %RH
Maximum wind / flow speed	30 m/s

Storage temperature:

with display	-5 ... +60 °C (+23 ... +140 °F)
without display	-40 ... +60 °C (-40 ... +140 °F)

IP rating	IP65
-----------	------

Compliance

EU directives and regulations	EMC Directive (2014/30/EU) RoHS Directive (2011/65/EU) amended by 2015/863
Electrical safety	EN 61326-1, industrial environment
EMC emissions	CISPR 32 / EN 55032, Class B
Compliance marks	CE, RCM

Spare parts and accessories

Conduit fitting + O-ring (M16 × 1.5 / NPT1/2")	210675SP
Conduit fitting + O-ring (M16 × 1.5 / PG9, RE-MS)	210674SP
Fastening flange assembly (screws included)	ASM210771SP
Porous PTFE filter	DRW239993SP
Membrane filter	ASM210856SP
Terminal block, blue	236620SP
USB cable for PC connection	219690
Connection cable for HM70 handheld meter	219980SP
HUMICAP® 180R humidity sensor	HUMICAP180R
HUMICAP® 180V humidity sensor (catalytic)	HUMICAP180V