



HUMICAP® Humidity and Temperature Probe HMP110



Features

- Miniature-size humidity transmitter
- Low power consumption and fast start-up for battery-powered applications
- Measurement range:
0 ... 100 %RH; -40 ... +80 °C
(-40 ... +176 °F)
- Cable detachable with standard M8 quick connector
- IP65 metal housing
- Optional RS-485 digital output supports Modbus RTU
- ±1.5 %RH measurement accuracy (0 ... 90 %RH)

HMP110 is a trouble-free and cost-effective humidity transmitter with high accuracy and good stability. It is suitable for volume applications or integration into other manufacturers' equipment. HMP110 is also suitable for glove boxes, greenhouses, fermentation and stability chambers, data loggers, and incubators.

Benefits

- Latest generation Vaisala HUMICAP® 180R sensor for best stability and high chemical tolerance
- HMP110R replacement probe service available for easy maintenance
- Comes with calibration certificate
- Optional dew point, wet bulb temperature, and enthalpy calculation

Easy Installation

The probe cable has a screw-on quick connector for easy installation. Different cable lengths and accessories are available.

Low Current Consumption

HMP110 is suitable for battery-powered applications because of its very low current consumption. It also has a fast start-up time.

Several Outputs

Temperature measurement is a standard feature in the HMP110, with dew point, wet bulb temperature, and enthalpy as optional calculated parameters. Three standard voltage outputs are available. An optional RS-485 output with Modbus support is also available.

Robust Design

The stainless steel body of HMP110 is classified as IP65. Thus, it survives rough conditions. HMP110 has high chemical tolerance thanks to the HUMICAP® 180R sensor.

Easy Maintenance

Maintaining measurement traceability is easy using the HMP110R replacement probe. We send you a replacement probe, you detach the old probe and send it back to us. This way the measurement is available at all times without interruptions.

Technical Data

Measurement Performance

Relative Humidity	
Measurement range	0 ... 100 %RH
Accuracy: ^{1) 2)}	
at 0 ... +40 °C (+32 ... +104 °F)	±1.5 %RH (0 ... 90 %RH) ±2.5 %RH (90 ... 100 %RH)
at -40 ... 0 °C, +40 ... +80 °C (-40 ... +32 °F, +104 ... +176 °F)	±3.0 %RH (0 ... 90 %RH) ±4.0 %RH (90 ... 100 %RH)
Factory calibration uncertainty at +20 °C (+68 °F)	±1.1 %RH (0 ... 90 %RH) ±1.8 %RH (90 ... 100 %RH)
Humidity sensor types	HUMICAP® 180R HUMICAP® 180V
Stability	±2 %RH over 2 years
Temperature	
Measurement range	-40 ... +80 °C (-40 ... +176 °F)
Accuracy (Probes with Analog Output):	
at 0 ... +40 °C (+32 ... +104 °F)	±0.2 °C (±0.36 °F)
at -40 ... 0 °C, +40 ... +80 °C (-40 ... +32 °F, +104 ... +176 °F)	±0.4 °C (±0.72 °F)
Accuracy (Probes with Digital Output):	
at +15 ... +25 °C (+59 ... +77 °F)	±0.1 °C (±0.18 °F)
at 0 ... +15 °C, +25 ... +40 °C (+32 ... +59 °F, +77 ... +104 °F)	±0.15 °C (±0.27 °F)
at -40 ... 0 °C, +40 ... +80 °C (-40 ... +32 °F, +104 ... +176 °F)	±0.4 °C (±0.72 °F)
Temperature sensor	Pt1000 RTD Class F0.1 IEC 60751
Calculated Parameters	
Measurement range for dew point temperature	-40 ... +80 °C (-40 ... +176 °F)
Measurement range for wet bulb temperature	-40 ... +80 °C (-40 ... +176 °F)
Measurement range for enthalpy	-40 ... 1540 kJ/kg (-10 ... +660 BTU/lb)
Accuracy at 20 °C (68 °F) and 80 %RH: ¹⁾	
Dew Point	
at 0 ... +40 °C (+32 ... +104 °F)	
• when dew point depression < +15 °C (+59 °F)	±1 °C (±33.8 °F)
• when dew point depression +15 ... +25 °C (+59 ... +77 °F)	±2 °C (±35.6 °F)
at -40 ... 0 °C, +40 ... +80 °C (-40 ... +32 °F, +104 ... +176 °F)	±2 °C (±35.6 °F)
• when dew point depression < +15 °C (+59 °F) ³⁾	
Wet Bulb Temperature	
at 0 ... +40 °C (+32 ... +104 °F) (0 ... 90 %RH)	±0.4 °C (0.72 °F) (probes with analog output)
	±0.3 °C (0.54 °F) (probes with digital output)
Enthalpy	
at +15 ... +25 °C (+59 ... +77 °F) (0 ... 90 %RH)	±1.2 kJ/kg (0.52 BTU/lb) (probes with analog output)
	±0.9 kJ/kg (0.4 BTU/lb) (probes with digital output)
Analog Outputs	
Accuracy at +20 °C (+68 °F)	±0.2 % of FS
Temperature dependence	±0.01 % of FS/°C (±0.006 % of FS/°F)

1) Including non-linearity, hysteresis, and repeatability.

2) With HUMICAP® 180V sensor, accuracy is not specified below -20°C (-4 °F) operating temperature.

3) Dew point depression = ambient temperature - dew point.

Mechanical Specifications

IP rating	IP65
Body thread	M12x1 / 10 mm (0.4 in)
Cable connector	M8 4-pin female (IEC 60947-5-2)
Materials	
Body	Stainless steel (AISI 316)
Grid filter	Chrome coated ABS plastic
Cable	Polyurethane or FEP
Weight	
Probe	17 g (0.6 oz)
Probe with 0.3 m (1 ft) cable	28 g (1 oz)

Operating Environment

Operating temperature	-40 ... +80 °C (-40 ... +176 °F)
EMC compliance	EN 61326-1, industrial environment

Inputs and Outputs

Power consumption	1 mA average, max. peak 5 mA
Operating Voltage ¹	
With 1 V / 2.5 V output	5 ... 28 VDC
With 5 V output	8 ... 28 VDC
With loop power converter	8 ... 28 VDC
With digital output	5 ... 28 VDC
Start-Up Time	
HMP110 probes with analog output	4 s at operating voltage 13.5 ... 16.5 VDC 2 s at other valid operating voltages
HMP110 probes with digital output	1 s
Outputs	
2 channels	0 ... 1 VDC / 0 ... 2.5 VDC / 0 ... 5 VDC / 1 ... 5 VDC
1-channel loop-power converter (separate module, compatible with humidity accuracy only)	4 ... 20 mA
Digital output (HMP110 probes with digital output)	RS-485 2-wire half duplex, supports Modbus RTU
External Loads	
0 ... 1 V	R _L min 10 kΩ
0 ... 2.5 V / 0 ... 5 V	R _L min 50 kΩ

1) Use lowest available operating voltage to minimize heating.

Spare Parts and Accessories

4 ... 20 mA loop power converter	UI-CONVERTER-1CB
Mounting bracket for converter	225979
Plastic M12 installation nuts, pair	18350SP
USB cable for PC connection	219690
Probe mounting clamp set, 10 pcs	226067
Probe mounting flange	226061

Sensor Protection

Plastic grid	DRW010522SP
Membrane filter	DRW010525SP
Stainless steel sintered filter	HM46670SP
PTFE sintered filter	DRW244938SP
Stainless steel grid filter	ASM212652SP

Connection Cables

Standard 0.3 m (1 ft)	HMP50Z032SP
Standard 3 m (9.8 ft)	HMP50Z300SP
+80 °C 1.5 m (+176 °F 5 ft)	225777SP
+80 °C 3 m (+176 °F 10 ft)	225229SP
+180 °C 3 m (+356 °F 10 ft) FEP	226902SP
Connection cable for HM70	219980SP
Flat extension cable 1 m (3 ft) ¹⁾	CBL210649SP

¹⁾ Connecting HMP110 to M170 requires using both flat cable CBL210649SP and connection cable 219980SP.

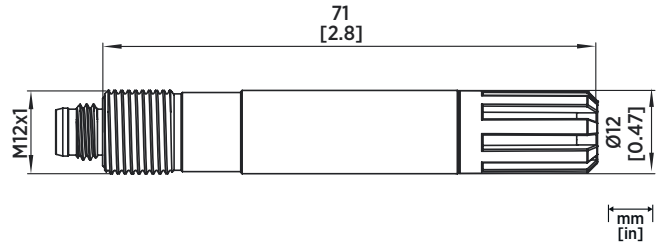

HMP110 Probe

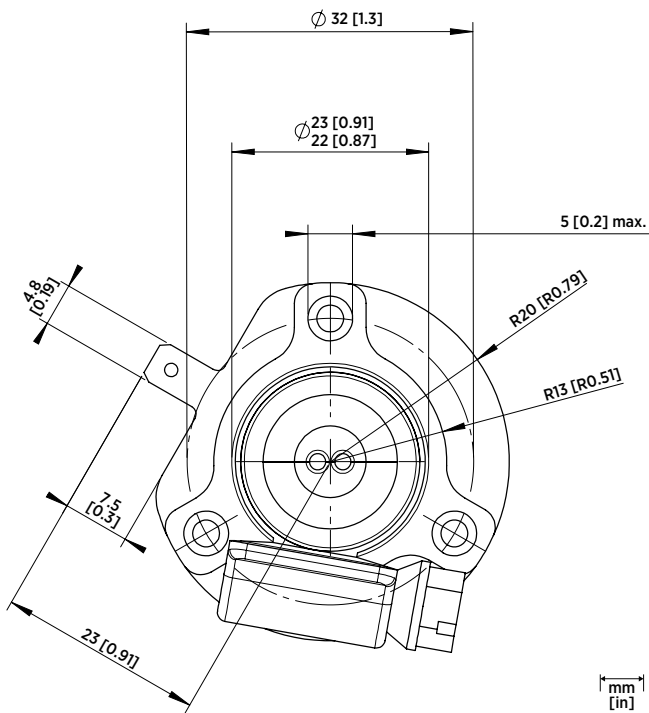

Probe Mounting Flange, Front View

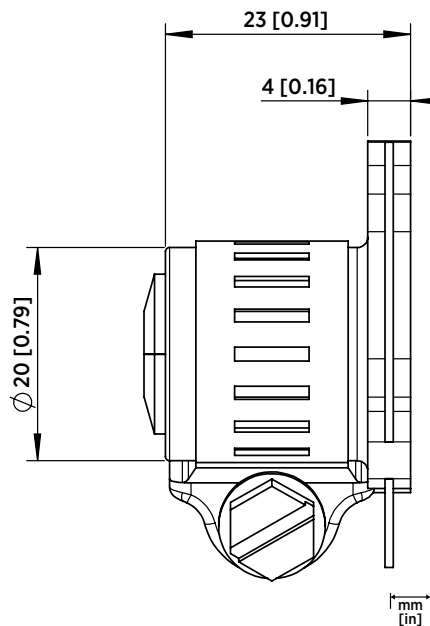

Probe Mounting Flange, Side View

