



HMP7 Relative Humidity and Temperature Probe

For High Humidities



Features

- RH accuracy up to $\pm 0.8\%$ RH
- Temperature accuracy up to $\pm 0.1\text{ }^\circ\text{C}$ ($\pm 0.18\text{ }^\circ\text{F}$)
- Temperature measurement range $-70 \dots +180\text{ }^\circ\text{C}$ ($-94 \dots +356\text{ }^\circ\text{F}$)
- Vapor and pressure proof construction
- Probe heating and sensor warming functions minimize condensation on probe
- Sensor purge provides superior chemical resistance
- Modbus RTU over RS-485
- Compatible with Indigo transmitters and Insight PC software
- Traceable calibration certificate: 6 points for humidity, 1 point for temperature

Vaisala HUMICAP® Humidity and Temperature Probe HMP7 is designed for applications that involve constant high humidity or rapid changes in humidity, such as drying and test chambers, combustion air, and other humidifiers and meteorological measurements, where measurement performance and chemical tolerance are essential.

Proven Vaisala HUMICAP® Performance

Vaisala is the original innovator of the thin-film capacitive humidity measurement technology, which has now become the industry standard in humidity measurement.

HUMICAP® technology results from Vaisala's 40-year experience in industrial humidity measurement, providing the best stability, fast response time, and low hysteresis in a wide range of applications.

Avoiding Condensation at Extreme Humidity

Probe heating functionality heats up not only the sensor, but the whole probe head. When probe temperature is heated above dew point temperature,

condensation on the probe can be avoided while measuring the dew point temperature of the process. By setting the temperature compensation value obtained, for example, with the TMP1 temperature probe, true relative humidity at process temperature can be measured while avoiding condensation by elevated probe temperature.

Vaisala Indigo Product Family

Indigo transmitters offer a variety of connectivity options through analog signals or digital outputs, configurable relays, and wireless (WLAN) configuration interface, providing a suitable solution for all industrial humidity measurements. The cable

length between the probe and transmitter can be extended to up to 30 meters. For more information, see www.vaisala.com/indigo.

Flexible Connectivity

The probe is compatible with Vaisala Indigo series of transmitters, and it can be used as a standalone digital Modbus RTU transmitter over RS-485 serial bus. For easy-to-use access to field calibration, device analytics, and configuration functionality, the probe can be connected to Vaisala Insight software for Windows®: see www.vaisala.com/insight.

Technical Data

Measurement Performance

Relative Humidity

Measurement range	0 ... 100 %RH
Accuracy at +23 °C (+73.4 °F) ¹⁾	±0.8 %RH (0 ... 90 %RH)
Factory calibration uncertainty ²⁾	±0.5 %RH (0 ... 40 %RH) ±0.8 %RH (40 ... 95 %RH)
T ₆₃ response time	15 s
Sensor options	HUMICAP® R2 HUMICAP® R2C ³⁾ HUMICAP® 180VC ^{3) 4)}

Temperature

Measurement range	-70 ... +180 °C (-94 ... +356 °F)
Accuracy at +23 °C (+73.4 °F) ¹⁾	±0.1 °C (±0.18 °F)
Factory calibration uncertainty ²⁾	±0.1 °C (±0.18 °F) at +23 °C (+73.4 °F)
Sensor	Pt100 RTD Class F0.1 IEC 60751

- 1) Defined against calibration reference. Including non-linearity, hysteresis, and repeatability.
 2) Defined as ±2 standard deviation limits. Small variations possible; see calibration certificate.
 3) Chemical purge feature available with this sensor.
 4) H₂O₂ resistant. With HUMICAP® 180VC sensor, accuracy is not specified below -20 °C (-4 °F) operating temperature.

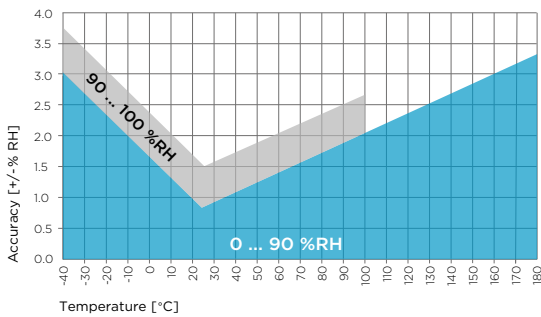

HMP7 Humidity Measurement Accuracy as Function of Temperature

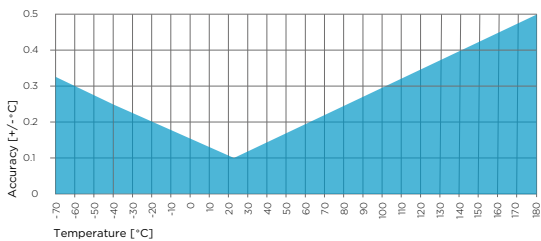

HMP7 Temperature Measurement Accuracy over Full Range

Mechanical Specifications

Connector	M12 5-pin A-coded male
Weight	310 g (10.9 oz)
Materials	
Probe	AISI316L
Probe body	AISI316L
Cable jacket	FEP

Operating Environment

Operating temperature for probe body	-40 ... +80 °C (-40 ... +176 °F)
Operating temperature for probe head	-70 ... +180 °C (-94 ... +356 °F)
Operational pressure	< 10 bar
Operating environment	Suitable for outdoor use
Measurement environment	For air, nitrogen, hydrogen, argon, helium, oxygen, and vacuum ¹⁾
IP rating of probe body	IP66
EMC compatibility	EN61326-1, industrial environment

1) Consult Vaisala if other chemicals are present. Consider safety regulations with flammable gases.

Inputs and Outputs

Operating voltage	18 ... 30 VDC
Current consumption	10 mA typical, 500 mA max.
Digital output	RS-485, non-isolated
Protocols	Modbus RTU

Output Parameters

Relative humidity, temperature, dew point temperature, wet-bulb temperature, absolute humidity, mixing ratio, water concentration, water mass fraction, water vapor pressure, enthalpy

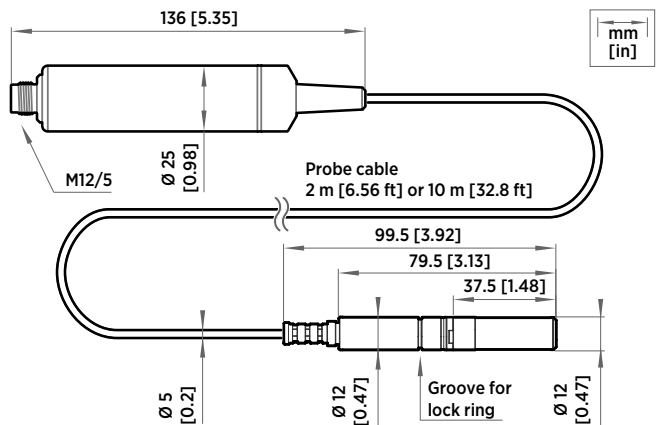

HMP7 Probe Dimensions

Accessories

Duct installation kit for RH probe	210697
Solar radiation shield	DTR502B
Cable gland M20×1.5 with split seal	HMP247CG
Swagelok® for 12 mm probe, 1/2" ISO thread	SWG12ISO12
Swagelok® for 12 mm probe, 3/8" ISO thread	SWG12ISO38
Swagelok® for 12 mm probe, 1/2" NPT thread	SWG12NPT12
USB PC connection cable ¹⁾	242659

1) Vaisala Insight software for Windows available at www.vaisala.com/insight

