

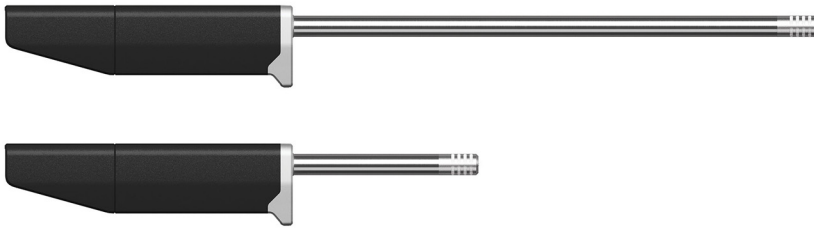

HMP80 Series Handheld Humidity and Temperature Probes

For spot-checking applications



Features

- Portable design optimized for industrial spot-checking and field calibration
- RH accuracy up to $\pm 0.8\%$ RH
- Temperature accuracy up to $0.1\text{ }^{\circ}\text{C}$ ($0.18\text{ }^{\circ}\text{F}$)
- Wide temperature measurement range
- Condensation-tolerant
- Sensor purge improves long-term stability and chemical resistance
- Compatible with Indigo80 handheld indicator, Indigo transmitters, and Insight PC software
- Calibration certificate included

Vaisala HUMICAP® Handheld Humidity and Temperature Probes HMP80 Series have been designed for portable use, especially with the Indigo80 handheld indicator. The combination of HMP80 probe and Indigo80 is ideal for spot-checking and field calibration of installed Vaisala humidity instruments.

Proven Vaisala HUMICAP performance

Vaisala is the original innovator of the thin-film capacitive humidity measurement technology, which has now become the industry standard in humidity measurement.

The HUMICAP technology results from Vaisala's 40-year experience in industrial humidity measurement, providing the best stability, fast response time, and low hysteresis in a wide range of applications.

HMP80 series probes are delivered with standard factory calibration certificates, with accredited calibration as an option. The probes can therefore be used as a working standard in field calibration.

Robust design for handheld measurements

The HMP80 series probes are available in two lengths offering similar measurement performance. The longer one is designed for measurements in more extreme temperatures.

The design of the probe handle has been optimized for manual operation in versatile measurement environments. The IP67-classified probe handle offers excellent protection against moisture and dust with the probe connection cable attached. Also the cable connection is protected against mechanical stress by the robust design of the handle.

Flexible connectivity

HMP80 probes are optimized for portable spot-checking, field calibration, and data logging use with the Indigo80 handheld indicator. They can also be connected to Indigo transmitters. For easy-to-use access to device analytics and configuration, HMP80 probes can be connected to Vaisala Insight software for Windows®.

For more information, see www.vaisala.com/indigo and www.vaisala.com/insight.

Technical data

HMP80 series measurement performance

Relative humidity

Measurement range	0 ... 100 %RH
Accuracy at +23 °C (73.4 °F) ¹⁾	±0.8 %RH (0 ... 90 %RH)
T ₆₃ response time	15 s
Sensor	HUMICAP® R2C ²⁾

Temperature

Measurement range	HMP80N: -20 ... +60 °C (-4 ... +140 °F) HMP80L: -50 ... +120 °C (-58 ... +248 °F), short-time measurement range -50 ... +180 °C (-58 ... +356 °F)
Accuracy at +23 °C (+73.4 °F) ¹⁾	0.1 °C (0.18 °F)
Sensor	Pt100 RTD Class F0.1 IEC 60751

- 1) Defined against calibration reference. Including non-linearity, hysteresis, and repeatability.
2) With sensor purge and sensor warming functionality.

HMP80 series operating environment

Operating temperature of probe body	-10 ... +60 °C (-14 ... +140 °F)
Operating temperature of probe head	HMP80N: -20 ... +60 °C (-4 ... +140 °F) HMP80L: -50 ... +120 °C (-58 ... +248 °F)
Storage temperature	-20 ... +60 °C (-4 ... +140 °F)
Measurement environment	For air, nitrogen, hydrogen, argon, helium, oxygen, and vacuum ¹⁾
Chemical tolerance	Temporary exposure during cleaning: <ul style="list-style-type: none"> • Deionized water • Isopropyl alcohol (70 %) • H₂O₂ (2000 ppm, non-condensing) • Acetone

IP rating of probe handle:	
With probe connection cable connected to the probe	IP67
Without cable	IP55

- 1) Consult Vaisala if other chemicals are present. Consider safety regulations with flammable gases.

HMP80 series inputs and outputs

Operating voltage	15 ... 30 V DC
Current consumption	10 mA typical, 500 mA max.
Digital output	RS-485, non-isolated

HMP80 series mechanical specifications

Connector type	M12 5-pin A-coded male
Weight	HMP80N: 200 g (7 oz) HMP80L: 300 g (10 oz)
Materials	
Probe handle	Polyamide (PA) and thermoplastic elastomer (TPE)
Probe shaft	Stainless steel (AISI 316L)
Filters	HMP80N: Stainless steel (AISI 316L) ¹⁾ HMP80L: Porous stainless steel (AISI 316L) ²⁾

- 1) With holes and without an additional filter membrane. Vaisala item code of filter: DRW255306SP.
2) Vaisala item code: HM47280SP

HMP80 series output parameters

Absolute humidity (g/m ³)	Relative humidity (%RH)
Absolute humidity at NTP (g/m ³)	Relative humidity (dew/frost) (%RH)
Dew point temperature (°C)	Temperature (°C)
Dew/frost point temperature (°C)	Water concentration (ppmv)
Dew/frost point temperature at 1 atm (°C)	Water concentration (wet basis) (vol-%)
Dew point temperature at 1 atm (°C)	Water mass fraction (ppmw)
Dew point temperature difference (°C)	Water vapor pressure (hPa)
Enthalpy (kJ/kg)	Water vapor saturation pressure (hPa)
Mixing ratio (g/kg)	Wet-bulb temperature (°C)

HMP80 series compliance

EU directives and regulations	EMC Directive (2014/30/EU) RoHS Directive (2011/65/EU) amended by 2015/863
EMC compatibility	EN 61326-1, industrial environment
Compliance marks	CE, China RoHS, RCM, UKCA

HMP80 series spare parts and accessories

Probe connection cable (M12-M12), 1.5 m (4.11 ft)	272075SP
Flat cable for probes (M12-M12), 1.0 m (3.4 ft)	CBL210493SP
Indigo USB adapter	USB2
Sintered stainless steel filter (HMP80N, HMP80L)	HM47280SP
Plastic PPS grid filter (HMP80N, HMP80L)	DRW010276SP
PPS grid with SS netting (HMP80N, HMP80L)	DRW010281SP
Slotted MIM filter (HMP80N)	DRW255306SP
Slotted MIM filter with membrane (HMP80N)	ASM214606SP

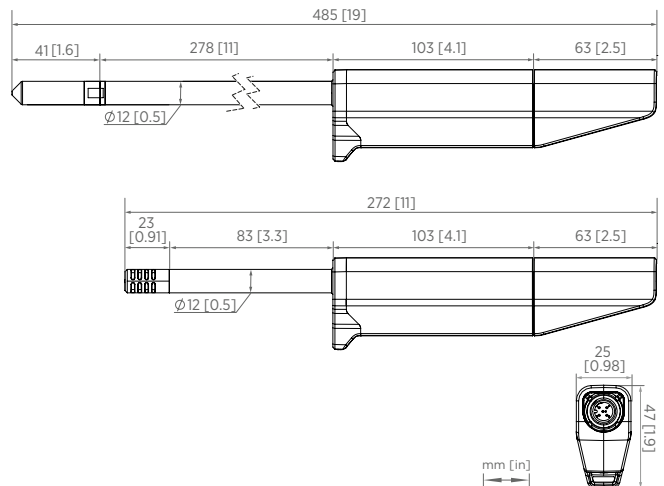

Dimensions of HMP80L (top) and HMP80N (bottom), side and bottom view