

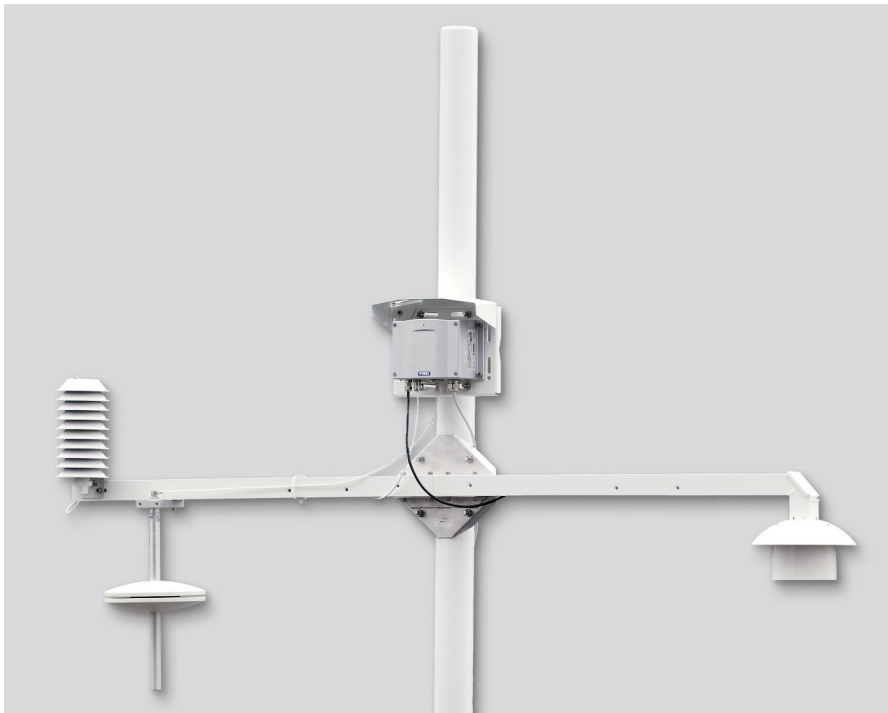

# HMT330MIK Meteorological Installation Kit



HMT337 and PTU307 feature warmed probe technology. Installed with the HMT330MIK kit either one forms the right choice for reliable humidity measurement in humid weather conditions.

## Features

- For outdoor humidity and temperature measurements
- Can be ordered in a variety of configurations
- Used together with HMT337 transmitter or PTU307
- Vaisala SPH 10/20 Static Pressure Head eliminates effectively pressure variations in the barometer caused by wind

## HMT337/PTU307 Features

- Warmed probe provides true humidity readings in condensing conditions
- Humidity measurement expressed as relative humidity and/or dew point temperature
- Easy field calibration with HM70 hand-held meter

Vaisala Meteorological Installation Kit HMT330MIK enables Vaisala HUMICAP® Humidity and Temperature Transmitter HMT337 to be installed outdoors to obtain reliable measurements for meteorological purposes.

## True Humidity Readings in Condensing Conditions

In weather observations dew formation makes reliable humidity measurement difficult. When dew has formed on the humidity sensor, it is impossible to obtain a true reading until this dew evaporates.

Both PTU307 and HMT337 avoid this problem by warming the probe. When warmed, the relative humidity inside the probe stays below the ambient level. With an accurate temperature measurement, the ambient dew point can be calculated precisely. To obtain the ambient relative humidity, an additional probe measures the ambient temperature, and the transmitter calculates the relative humidity from the dew point and temperature values.

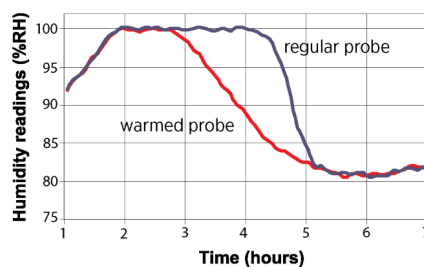

After a period of 100 % relative humidity, the warmed probe measures the true humidity, whereas the non-warmed probe takes time to recover from the condensation.

## Open Shield Prevents Microclimates

The warmed probe of HMT337/PTU307 is mounted in a shield which is open at the bottom to ensure steady air circulation to the sensor even in calm weather.

In traditional radiation shields sleet or snow can accumulate on the shield and prevent the proper air circulation through the shield, and create a humid microclimate until the snow melts.

## Essential for Critical Weather Measurements

Obtaining a true humidity reading is particularly important e.g. in traffic safety: at airports and at sea as well as on the roads. It is essential, for example, in fog and frost prediction.



For calibration, a portable HMP77 reference probe is easy to attach beside HMT337 or PTU307 probe.

# Technical Data

Radiation shield options:

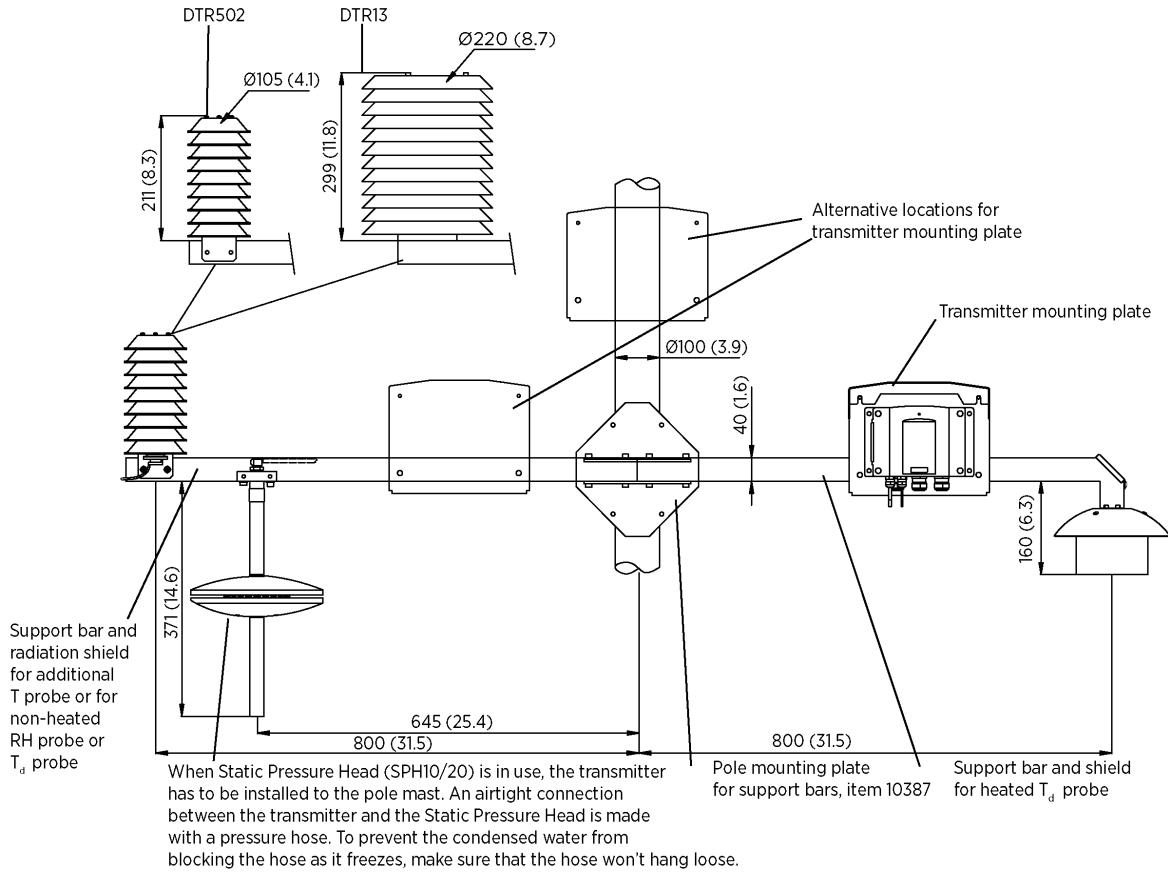

Dimensions in mm (inches)

Vaisala Meteorological Installation Kit		HMT330MIK	1	2	3	4	5	PRICE
1	Support bar & shield for warmed Td probe	<b>No support bar &amp; shield for warmed Td probe</b> <i>Support bar &amp; shield for warmed Td probe</i>	0					
			1					
2	Support bar and radiation shield for additional T probe or for non-warmed RH or Td probe	<b>No support bar or radiation shield</b> <i>Support bar with DTR502 shield for T probe</i> <i>Support bar with DTR13 shield for T probe</i> <i>Support bar with DTR502 shield for non-warmed RH or Td probe</i> <i>Support bar with DTR13 shield for non-warmed RH or Td probe</i>		A				
				B				
				C				
				D				
				E				
3	Support bar mounting plate	<b>No mounting plate</b> <i>Pole mounting plate for support bar/bars (item 10387)</i>	0					
			1					
4	Additional transmitter mounting plate (incl. rain shield)	<b>No additional transmitter mounting plate</b> <i>Transmitter mounting plate for support bar assembly</i> <i>Transmitter mounting plate for pole assembly</i>		A				
				B				
				C				
5	Static Pressure Head	<b>No Static Pressure Head</b> <i>Static Pressure Head SPH10 Only for the PTU300</i>	0					
			1					
							TOTAL	
							QTY	
							TOTAL VALUE	

Order form

