



# Indigo 200 series transmitters

For Vaisala smart probes



## Features

- Transmitter for Vaisala Indigo smart probes:
  - HMP series humidity and temperature probes
  - DMP series dew point probes
  - GMP250 series CO<sub>2</sub> probes
  - HPP270 series vaporized hydrogen peroxide probes
  - MMP8 moisture in oil probe
- Wireless interface for configuration and temporary use
- Operating temperature: -40 ... +60 °C, with display -20 ... +60 °C
- LCD color display (optional non-display version for analog model)
- IP65 enclosure
- 24 VAC/DC power supply input
- Indigo 201: 3 analog outputs (mA or V)
- Indigo 202: RS-485 with Modbus RTU
- 2 configurable relays

Vaisala Indigo 200 series transmitters are host devices for displaying measurement values from Vaisala Indigo compatible probes and/or transmitting them to automation systems through analog signals, Modbus RTU communication, or relays.

These probe hosts are plug-and-play devices for current and future Vaisala Indigo compatible probes. The host device has a color LCD display; Indigo 201 is also available as a non-display version that uses an LED indicator for notifications.

Vaisala Indigo compatible probes are connected either directly to the host or by using a cable between Indigo 200 and the probe.

Indigo 200 has a browser-based wireless configuration interface for mobile devices and computers that support a wireless connection (IEEE 802.11 b/g/n WLAN). The host device and the probes connected to it can be configured using the wireless user interface. It also allows for temporary viewing of the measurement data.

The surface of the Indigo 200 enclosure is smooth, which makes it easy to clean. It is also resistant to dust and most chemicals, such as H<sub>2</sub>O<sub>2</sub> and alcohol-based cleaning agents.



Wireless configuration interface example (desktop and mobile views)  
For more information on Indigo transmitters and the Indigo product family, see [www.vaisala.com/indigo](http://www.vaisala.com/indigo).

# Technical data

## General

- LCD color display (Indigo 201: optional non-display version)
- Wireless (WLAN) configuration interface: connect to Indigo 200 and use the browser-based user interface for device configuration and measurement data viewing

## Compatible Indigo smart probes

Measurement type	Probe models
Humidity and temperature	HMP1, HMP3, HMP4, HMP5, HMP7, HMP8, HMP9
Temperature	TMP1
Dew point	DMP5, DMP6, DMP7, DMP8
CO <sub>2</sub>	GMP251, GMP252 <sup>1)</sup>
Vaporized hydrogen peroxide	HPP271, HPP272
Moisture in oil	MMP8

<sup>1)</sup> All GMP251 and GMP252 probes manufactured from 2017 onwards (serial numbers starting with the letter N or later in alphabetical order) have full Indigo compatibility.

## Operating environment

Operating temperature	With display -20 ... +60 °C (-4 ... +140 °F) Without display -40 ... +60 °C (-40 ... +140 °F)
Storage temperature	-40 ... +70 °C (-40 ... 158 °F)
Chemical tolerance	Temporary exposure during cleaning: <ul style="list-style-type: none"> <li>• H<sub>2</sub>O<sub>2</sub> (6000 ppm, non-condensing)</li> <li>• Alcohol-based cleaning agents such as ethanol and IPA (max. 70 % concentrate)</li> </ul>

## Inputs and outputs

Power supply input	15 ... 30 VDC <sup>1)</sup> 24 VAC ±10 % 50/60 Hz
Relay contacts x 2	Max. switching power 30 W Max. switching current 1 A Max. switching voltage 40 VDC / 28 VAC
<b>Indigo 201 model</b>	
Three analog outputs (voltage or current)	Voltage: 0 ... 1 V, 0 ... 5 V, 0 ... 10 V, 1 ... 5 V, scalable, min. load 1 kΩ Current: 4 ... 20 mA, 0 ... 20 mA, scalable, max. load 500 Ω
Accuracy of analog outputs at 20 °C	±0.1 % full scale for 0 ... 10 V and 0 ... 20 mA
<b>Indigo 202 model</b>	
Digital communications	RS-485, Modbus RTU

<sup>1)</sup> When used with the HMP7 probe, the minimum required power supply input is 18 VDC.

## Mechanical specifications

Housing classification	IP65
Housing material	PC/ABS plastic
Display window material	PMMA plastic
Connection screw terminals	26 AWG ... 20 AWG
Weight	402 g (14.2 oz)
Dimensions (H×W×D)	149 × 135 × 43 mm (5.87 × 5.31 × 1.7 in)

## Compliance

Safety standard	IEC/UL/EN 61010-1
Networking standards (wireless configuration interface WLAN access point)	IEEE 802.11 b/g/n compliant
EMC compliance	EN61326-1, Generic Environment
Contains	FCC ID QOQ-WGM110, IC 5123A-WGM110, MIC 209-J00197, MSIP-CRM-BGT-WGM110

## Spare parts and accessories

Probe connection cable, 1 m	INDIGOCABLE1M
Probe connection cable, 3 m	INDIGOCABLE3M
Probe connection cable, 5 m	INDIGOCABLE5M
Probe connection cable, 10 m	INDIGOCABLE10M

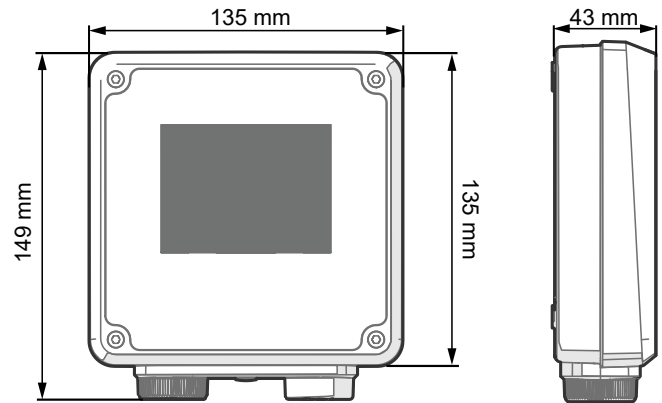

Indigo 200 series dimensions

