



MHT410 Moisture, Hydrogen, and Temperature Transmitter

For online transformer condition monitoring



Features and benefits

- Measures moisture and hydrogen directly in transformer oil
- Compatible with mineral oil, natural ester oil, and synthetic ester oil
- Easy to install
- Provides early warning on potential transformer faults
- Unique probe design allows for direct measurement in oil
- 5-year standard warranty
- Robust design providing reliable operation and no false alarms
- Maintenance-free operation
- No cross-sensitivity to other gases
- Indigo 520 compatible, with easy access to measurement data

Vaisala MHT410 Moisture, Hydrogen, and Temperature Transmitter provides reliable online monitoring of insulating oil in power transformers.

Real-time measurement

Vaisala Moisture, Hydrogen, and Temperature Transmitter MHT410 provides an accurate real-time measurement result for critical parameters measured in oil, enabling reliable conclusions on the transformer's condition. With its unique probe design, MHT410 delivers accurate measurement and trend data about the health of the transformer in real time.

Enabling proactive maintenance decisions

All of the transmitter's measured parameters are available through digital and analog outputs, providing information on transformer fault situations and enabling timely, proactive maintenance decisions to minimize expensive service shutdowns and outages.

MHT410 is also compatible with the Vaisala Indigo 500 series transmitters. With its local graphical display, Indigo 520 is a great addition to MHT410. It helps you to identify data trends at the site, as well as power the MHT410 with a single-wire solution.

Robust and maintenance-free operation

MHT410 is designed for ease of use in demanding environments. It has undergone extensive testing to ensure it withstands wide temperature changes, vibration, and harsh outdoor conditions. The transmitter has no consumables or moving parts that could break, and is encased in an IP66-rated metal housing equipped with a weather shield.

Every unit is individually tested for a pressure of at least 10 bar and also withstands vacuum conditions. Special attention has been given to EMC tolerance: for example, all electrical connections are isolated. MHT410 can also tolerate short-term power outages.

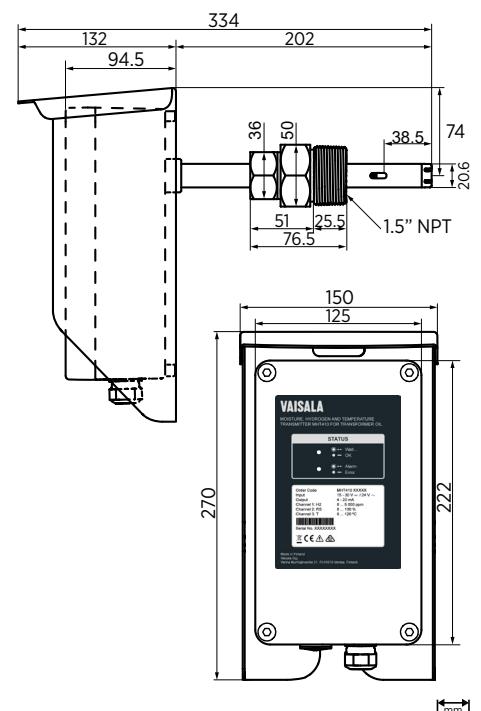

Technical Data

Measurement performance

Hydrogen

Measurement range (in oil)	0 ... 5000 ppm _v
Accuracy ¹⁾	±10 % of reading or ±15 ppm _v (whichever is greater)
Repeatability	±10 % of reading or ±15 ppm _v (whichever is greater)
Minimum detection limit	15 ppm _v
Typical long-term stability	3 % of reading / year
Cross sensitivity to other gases	< 2 % (CO ₂ , C ₂ H ₂ , C ₂ H ₄ , CO)
Response time	63 % of full response: 2.5 h (when sensor is not in reference cycle) 90 % of full response: 17 h
Warm-up time	2 h, 12 h for full specification
Sensor	Catalytic palladium-nickel alloy film solid-state sensor

Moisture in oil

Measurement range (in oil)	0 ... 100 %RS / a _w 0 ... 1
Response time (90 % of full response at +20 °C (+68 °F) in still oil)	10 min
Sensor	HUMICAP® 180L2
Accuracy (including non-linearity, hysteresis, and repeatability):	
0 ... 90 %RS	±2 %RS (a _w ± 0.02)
90 ... 100 %RS	±3 %RS (a _w ± 0.03)

Temperature

Measurement range	-40 ... +120 °C (-40 ... +248 °F)
Accuracy at +20 °C (+68 °F)	±0.2 °C (0.36 °F)
Sensor	Pt1000 RTD Class F0.1 IEC 60751

¹⁾ Accuracy specified is the accuracy during calibration against gas in oil standard. Field performance may be affected, for example, by variation in hydrogen solubility (partition coefficients) between different mineral oils.

Inputs and outputs

Operating voltage	15 ... 30 VDC, 24 VAC (±15 %) (power supply input is galvanically isolated) ¹⁾
Power consumption	Typical 4 W, maximum 12 W

Analog output (current) ¹⁾

Channels	3 isolated 4 ... 20 mA (loop powering)
External load	Max. 500 Ω
Error status indication in case of device error	3.5 mA default, user-configurable for each channel
mA output accuracy at +20 °C (+68 °F)	±0.125 % full scale
Temperature dependence of the analog outputs	±0.006 % / °C full scale

Digital outputs ¹⁾

Interfaces	Isolated RS-485 half-duplex RS-485 (Service Port, non-isolated)
Protocols	Modbus RTU, DNP3, serial ASCII
Screw terminals	Wire size AWG 22-14 Single wire (solid) 1.5 mm ² Stranded wire (flex.) 1.0 mm ² Recommended wire torque 0.4 Nm

¹⁾ Max. isolation voltage 1.5 kV DC.

Mechanical specifications

Mechanical connection on transmitter	1.5" NPT (male)
Cable gland (optional, for use with Indigo 520)	M20×1.5 for cable diameter 5 ... 9 mm (0.20 ... 0.35 in)
Cable gland (optional)	M20×1.5 for cable diameter 8 ... 11 mm (0.31 ... 0.43 in)
Cable gland (optional)	M20×1.5 for cable diameter 11 ... 14.5 mm (0.43 ... 0.57 in)
Conduit fitting (optional)	1/2" NPT
Interface cable (optional, pre-assembled)	5 m (16 ft 5 in), 9.2 mm (0.36 in) outer diameter
Interface cable (optional)	10 m (33 ft), 9.2 mm (0.36 in) outer diameter
Interface cable (optional, for use with Indigo 520)	10 m (33 ft), 6.2 mm (0.24 in) outer diameter
Housing material	AlSi 10 Mg
IP rating	IP66
Transmitter weight without cables	4.1 kg (9.04 lb)
Self-diagnostics indication	Status LEDs, analog output, Modbus
Integrated data logging capabilities	Non-volatile memory, up to 44 years' storage with default logging
Individual functional test reports	Calibration test reports for moisture, hydrogen, and temperature; probe leak test report (5 bara nominal)
Factory warranty	5 years

Operating environment

Oil type	Mineral oil / Natural ester oil / Synthetic ester oil
Oil temperature	-20 ... +75 °C (-4 ... +167 °F)
Operating temperature (electronics)	-40 ... +60 °C (-40 ... +140 °F)
Storage temperature	-40 ... +60 °C (-40 ... +140 °F)
Operating humidity	0 ... 100 %RH, condensing
Pressure tolerance (probe, short-term)	Max. 10 bara
Pressure tolerance (probe, continuous)	Max. 4 bara
Temperature tolerance, sensor head	-40 ... +120 °C (-40 ... +248 °F)
Integrated protection for short power outages	> 3 s
EMC standard EN 61326-1, Industrial environment; CISPR22 class B emission limits when DC powered	Fulfills the requirements of IEC 61000-6-5 in the following tests: IEC 61000-4-2, IEC 61000-4-3, IEC 61000-4-4, IEC 61000-4-5, IEC 61000-4-6, IEC 61000-4-8, IEC 61000-4-11, IEC 61000-4-12, IEC 61000-4-16, IEC 61000-4-17.

