



TMI110 Temperature Transmitter

For high-accuracy measurements in HVAC applications



Features

- Accurate temperature measurement of liquids and air
- Very fast response time
- 1-point traceable calibration (certificate included)
- Analog (4 ... 20 mA) and Modbus® RTU output options
- Installed in a thermowell for measurement in liquids
- Optimized for building automation and HVAC process control

The high-accuracy immersion temperature transmitter TMI110 is designed for measuring cooling/heating water temperatures in HVAC automation systems. TMI110 can also be used for air temperature measurements in air ventilation ducts. The transmitter has a fast response time, enabling precise and reliable control of HVAC systems.

The TMI110 transmitter belongs to the Vaisala HUMICAP® Humidity and Temperature Transmitter Series HMDW110, which includes transmitters for duct mounting, IP65-rated wall transmitters, immersion temperature transmitters, and outdoor transmitters with integrated radiation shields.

Highly accurate

The highly accurate TMI110 measures the temperature of liquid in cooling/heating systems, and the temperature of air in ventilation ducts. When measuring the temperature of liquid, the transmitter is installed in a thermowell. For air temperature measurements, the transmitter can be installed in a duct.

Temperature is measured with a Pt1000 sensor element (class A). The high accuracy and quick response time of the measurement enable precise and reliable control of HVAC systems.

Fast response time

Fast response time of measurement is a top priority in the design of TMI110, enabling instant response in the control loop. Speed and reliability are key factors in the measurement of cooling and heating processes, thus the capabilities of TMI110 are a significant advantage. The transmitter is optimal for building automation and HVAC process control.

Traceable accuracy

All TMI110 transmitters are individually adjusted and delivered with a traceable (ISO 9001) calibration certificate. If required later on, the transmitter can also be field-calibrated using a Vaisala handheld meter or Vaisala Insight PC software.

Technical data

Measurement performance

Temperature

Measurement range	-40 ... +120 °C (-40 ... +248 °F)
Accuracy at +20 °C (+68 °F)	±0.1 °C (±0.18 °F)
Temperature dependence	±0.01 °C/°C
Response time (T63) at +20 °C (+68 °F)	< 8 s typical
Temperature sensor	Pt1000 RTD Class A, IEC 60751
Factory calibration uncertainty at +20 °C (+68 °F)	±0.1 °C (±0.18 °F)

Operating environment

Operating environment, probe	-40 ... +120 °C (-40 ... +248 °F)
Operating environment, electronics	-40 ... +60 °C (-40 ... +140 °F)
Storage temperature	-40 ... +60 °C (-40 ... +140 °F)
IP rating	IP65
NEMA rating	NEMA 4

Compliance

EU directives	EMC Directive (2014/30/EU) RoHS Directive (2011/65/EU) amended by 2015/863
Electrical safety	EN 61326-1, industrial environment
EMC emissions	CISPR 22 / EN 55022, Class B
Compliance marks	CE, RCM

Inputs and outputs

Devices ordered with analog output

Outputs	4 ... 20 mA, loop powered
Loop resistance	0 ... 600 Ω
Supply voltage	20 ... 28 V DC at 600 Ω load 10 ... 28 V DC at 0 Ω load

Devices ordered with Modbus output

Interface	RS-485, not isolated, no line termination
Default serial settings	19200 bps N 8 2
Protocol	Modbus RTU
Supply voltage	10 ... 28 V DC

Mechanical specifications

Probe material	Stainless steel
Probe diameter	6 mm (0.24 in)
Probe length	100 mm (3.94 in)
Screw terminal wire size	Max. 1.5 mm ² (AWG 16)
Standard housing color	White (RAL9003)
Housing material	PC + 10 %GF (UL-V0 approved)

Spare parts and accessories

Conduit fitting + O-ring (M16×1.5 / NPT1/2")	210675SP
Conduit fitting + O-ring (M16×1.5 / PG9, RE-MS)	210674SP
Terminal block, blue	236620SP
USB cable for PC connection	219690
Connection cable for HM70 handheld meter	219980SP

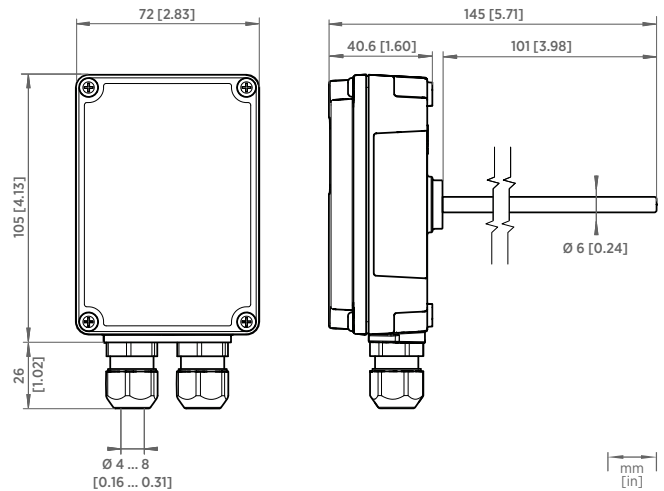

B212427EN-C