

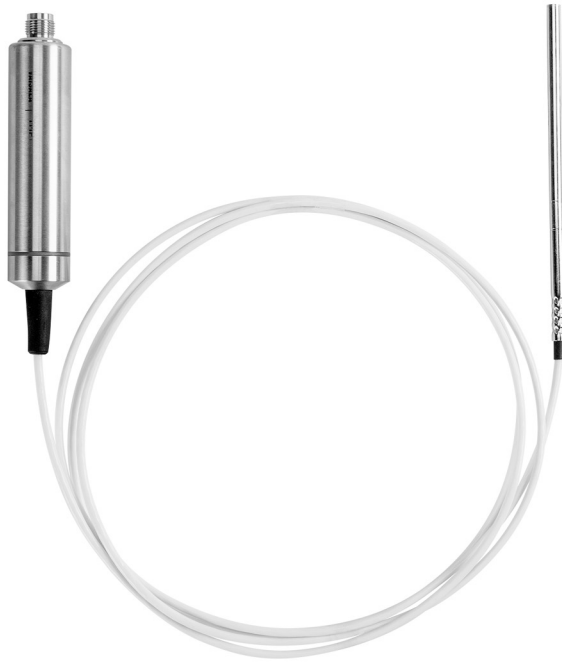

TMP1 Temperature Probe



Features

- Temperature accuracy up to ± 0.1 °C (± 0.18 °F)
- Temperature measurement range $-70 \dots +180$ °C ($-94 \dots +356$ °F)
- Modbus RTU over RS-485
- Compatible with Indigo transmitters and Insight PC software
- Traceable 2-point calibration certificate with calibration points at $+20$ and $+70$ °C ($+68$ and $+158$ °F)

Vaisala Temperature Probe TMP1 is designed for demanding temperature measurements in industrial applications such as pharmaceutical industry and calibration laboratories, where accuracy and robustness are essential.

Flexible Connectivity

The probe is compatible with Vaisala Indigo series of transmitters, and it can be used as a standalone digital Modbus RTU transmitter over RS-485 serial bus. For easy-to-use access to field calibration, device analytics, and configuration functionality, the probe can be connected to Vaisala Insight software for Windows®: see www.vaisala.com/insight.

Vaisala Indigo Product Family

Indigo transmitters offer a variety of connectivity options through analog signals or digital outputs, configurable relays, and wireless (WLAN)

configuration interface, providing a suitable solution for all industrial humidity measurements. The cable length between the probe and transmitter can be extended to up to 30 meters. For more information, see www.vaisala.com/indigo.

Relative Humidity Measurements in High Humidities

When the TMP1 probe is connected to a control system in parallel with HMP7 Relative Humidity and Temperature Probe, it is possible to have relative humidity measurement in actual process temperature while using probe heating in

the relative humidity probe. Probe heating helps to avoid condensation in situations where the dew point temperature of the process is close to the ambient temperature.

When the humidity probe is heated above dew point temperature, condensation can be avoided and the relative humidity in the actual process temperature can be back-calculated based on the true process temperature measurement received from TMP1.

Technical Data

Measurement Performance

Measurement range	-70 ... +180 °C (-94 ... +356 °F)
Accuracy at +23 °C (+73.4 °F) ¹⁾	±0.1 °C (±0.18 °F)
Factory calibration uncertainty ²⁾	±0.1 °C (±0.18 °F) at +23 °C (+73.4 °F)
Sensor	Pt100 RTD Class F0.1 IEC 60751

1) Defined against calibration reference. Including non-linearity, hysteresis, and repeatability.
 2) Defined as ±2 standard deviation limits. Small variations possible; see calibration certificate.

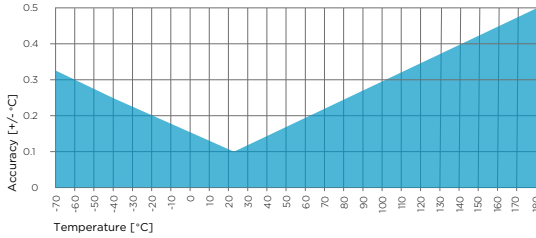

TMP1 Temperature Measurement Accuracy over Full Range

Operating Environment

Operating temperature for probe body	-40 ... +80 °C (-40 ... +176 °F)
Operating temperature for probe head	-70 ... +180 °C (-94 ... +356 °F)
Operating environment	Suitable for outdoor use
IP rating of probe body	IP66
EMC compatibility	EN61326-1, industrial environment

Inputs and Outputs

Operating voltage	15 ... 30 VDC
Current consumption	10 mA typical
Digital output	RS-485, non-isolated
Protocols	Modbus RTU
Output parameters	Temperature, water vapor saturation pressure

Mechanical Specifications

Connector	M12 5-pin A-coded male
Weight	224 g (7.9 oz)

Materials

Probe	AISI316L
Probe body	AISI316L
Cable jacket	FEP

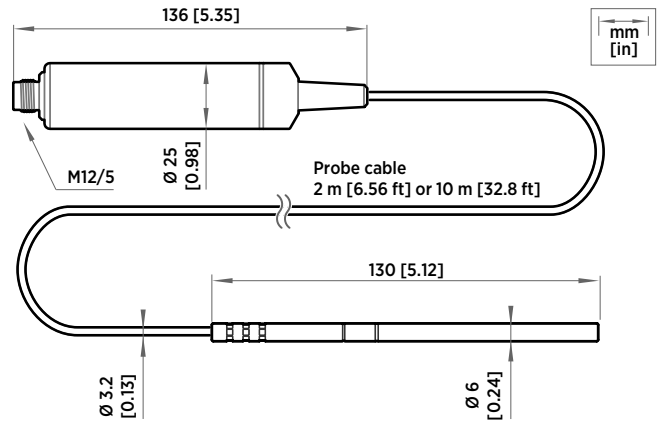

TMP1 Probe Dimensions

Accessories

Duct installation kit for T probe	215003
Swagelok® for 6 mm probe 1/8" ISO thread	SWG6ISO18
Swagelok® for 6 mm probe 1/8" NPT thread	SWG6NPT18
USB PC connection cable ¹⁾	242659

1) Vaisala Insight software for Windows available at www.vaisala.com/insight

