



Satron VG

Flush Mount

Pressure Transmitter

SATRON
instruments

SATRON VG pressure transmitters are our most widely used transmitters for measuring the pressure of clean gases, steam and non-crystallizing liquids. VG is compatible with the PASVE® mounting and service valve for easy access to the sensor even during process cycles. Transmitter is flush mounted that means that with Satron couplings or PASVE® the possibility of clogging is minimized.

VG is a 2-wire transmitter with HART® standard communication and can be used for ranges 0-4 kPa...0-25 MPa depending on the adjustability of the transmitter. The rangeability is 100:1 for types VG6-VG7.

The transmitter measurement diaphragm is welded to give durability in harsh environments. When the VG is used with a Satron coupling or PASVE® mounting and service valve the only wetted part is the measuring diaphragm. Several materials and coatings for the diaphragm are available to suit the process media used.

PRODUCT CERTIFICATIONS

European Directive Information:

Electro Magnetic Compatibility EMC directive

2014/30/EU

ATEX directive 2014/34/EU

Satron Instruments Inc. complies with the ATEX directive

European Pressure Equipment Directive (PED)

2014/68/EU

All pressure Transmitters

- Sound Engineering Practice

Transmitters with nominal pressure higher than 200 bar fulfill the requirements of the Conformity Assessment procedure Module A of the directive

Hazardous Locations Certifications:

European Certifications

ATEX Intrinsic Safety

Certification No:

DNV-2007-OSL-ATEX-1346X

PASVE® compatibility

VG is compatible with the standard PASVE® mounting and service valve to enable safe removal of the pressure transmitter from the process without stopping the process or without draining the tank.



ATEX INTRINSIC SAFETY (APPLIES ONLY TO ATEX MODELS)

Certification No:

DNV-2007-OSL-ATEX-1346X

 II 1 GD T135°C EEx ia II C T4 -20° ≤ T_{amb} ≤ 50 °C

 II 2 GD T135°C EEx ia II C T4 -20° ≤ T_{amb} ≤ 50 °C

Input parameters:

U_i = 28 V

I_i = 93 mA

P_i = 0.651 W

C_i = 5 nF

L_i = 0.2 mH

Special conditions for Safe Use (X)

The enclosure with plastic window and the plastic DIN43650 connector must not be installed in potentially explosive atmosphere requiring category 1 apparatus.

The non-conducting surface of the sensor element may be charged by the flow of non-conducting media, so there may be electrostatic hazard with IIC-gases. These units should be marked 2 GD.

The equipment shall be installed and connected according to the manufacturers instructions.

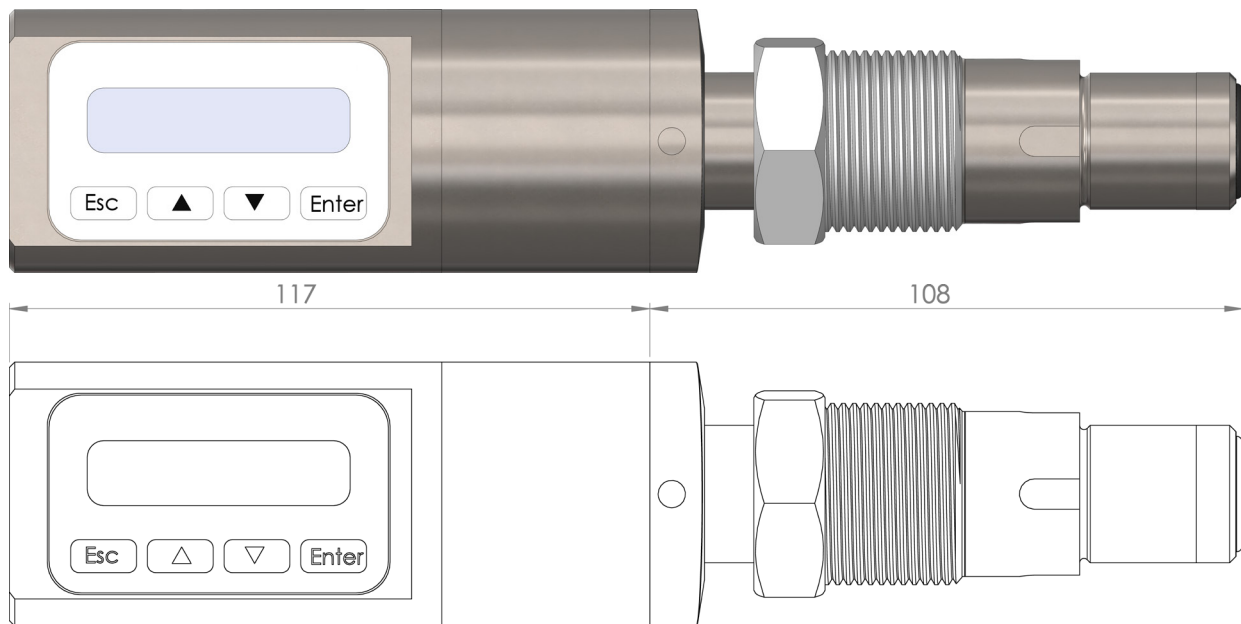

Standard model: VG5 with process connection 1, wetted part material AISI316L, fill fluid Silicone oil, housing with display N, without ATEX, normal temperature
Order code VG5S42SN0N, see following pages for details, selection chart on the last page

CHOOSING THE TRANSMITTER, see also selection table on the last page:

Measurement range

There are 8 types of VG transmitters for different measurement ranges. Transmitter types VGA are absolute pressure transmitters. Range means the measurement limit of the pressure sensor, from the minimum to the maximum pressure. Span is the transmitter's work range, minimum and maximum to which the transmitter can be calibrated. For example the VG3 has measurement range of -35 to +35 kPa, but the maximum span is 35 kPa, therefore calibration for the whole range is not possible, but the maximum calibration would be 0 to 35 kPa and minimum -35 to 0 kPa. If the calibration span is not specified the calibration will be done for the maximum range starting from 0 kPa. For available ranges, see selection chart on the last page.

Process seal options

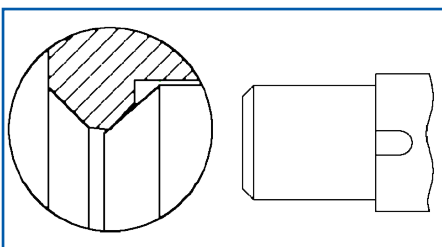

Process seal 4 metal/metal taper
Satron standard process connection
Diaphragm also on sealing face. All diaphragm materials available.

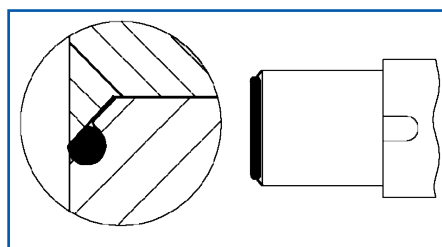

Process seal 5 O-ring FPM (Viton®)
3A approved process connection for hygienic applications.

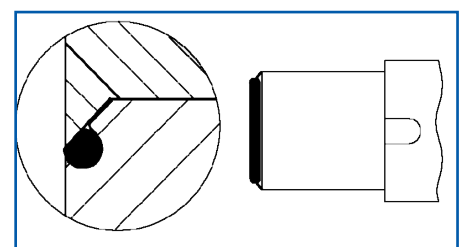

Process seal 6 O-ring EPDM
3A and EHEDG-certified process connection for hygienic applications.

Wetted part material options

Wetted part (part in contact with the process media) in VG Pressure Transmitters is the measuring diaphragm. Other parts are not in contact with process media when using VG compliant process couplings. Material of diaphragm should be chosen according to the process media. For help in choosing the material, please contact us with details of the process.

Available materials, see also restrictions above on process seal:

Diaphragm: AISI 316 (EN 1.4404)
 Hastelloy®C276 (EN 2.4819)¹⁾
 Tantalum ¹⁾

Titanium Gr2 (EN 3.7035)^{1) 2)}
Duplex (EN 1.4462)¹⁾

¹⁾ Not available for measurement range 3
²⁾ Minimum process temperature limit 0 °C

Diaphragm coating

Measuring diaphragm can be coated to improve the durability of the measurement head in abrasive environments

Available options: Gold/Rhodium coating
Diamond coating

Filling fluid

Silicone oil Standard option for fill fluid 3A and EHEDG certified
Inert oil For Chlorine and Oxygen media applications and other combusive processes

Housing options

Housing H

Housing with DIN43650 plug connector, no display, electrical inlet PG9.

Affordable option for rough environments

Materials:

Housing AISI316, Seals Viton® and NBR;
Test jacks MS358Sn/PVDF, protected with silicone rubber seal;

Plug connector: PA6-GF30 jacket, silicone rubber seal, AISI316 retaining screw

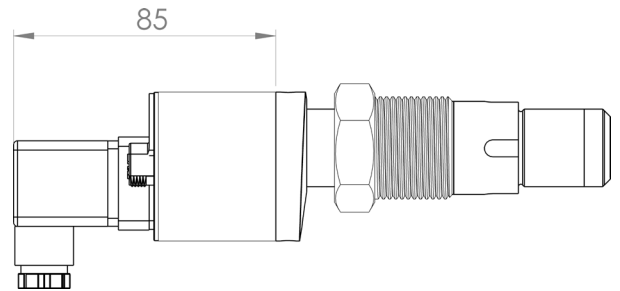

Housing T

Housing with DIN43650 plug connector and manual adjustment, no display, electrical inlet PG9.

Affordable option for rough environments

Materials:

Housing AISI316, Seals Viton® and NBR;
Test jacks MS358Sn/PVDF, protected with silicone rubber seal;

Plug connector: PA6-GF30 jacket, silicone rubber seal, AISI316 retaining screw

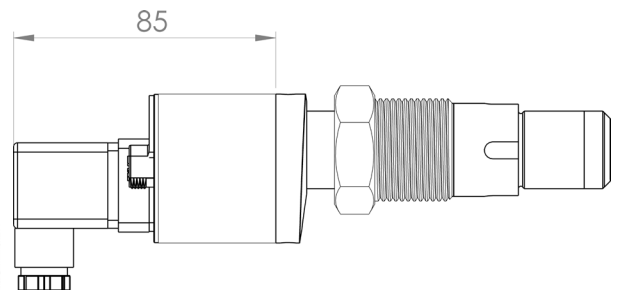
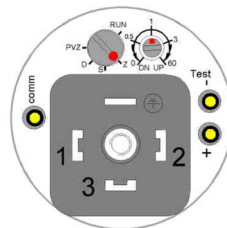

Housing M

Housing with junction box/terminal strip, no display, electrical inlet M20x1.5 cable gland.

Best option for the roughest environments

Materials:

Housing AISI303/316,
Seals Viton® and Nitrile;

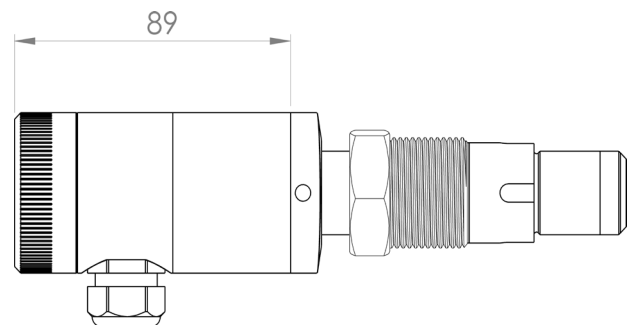

Housing N

Housing with junction box/terminal strip, with display, electrical inlet M20x1.5.

Display enables controlling the transmitter at site

Materials: Housing AISI303/316, Seals Viton® and Nitrile;

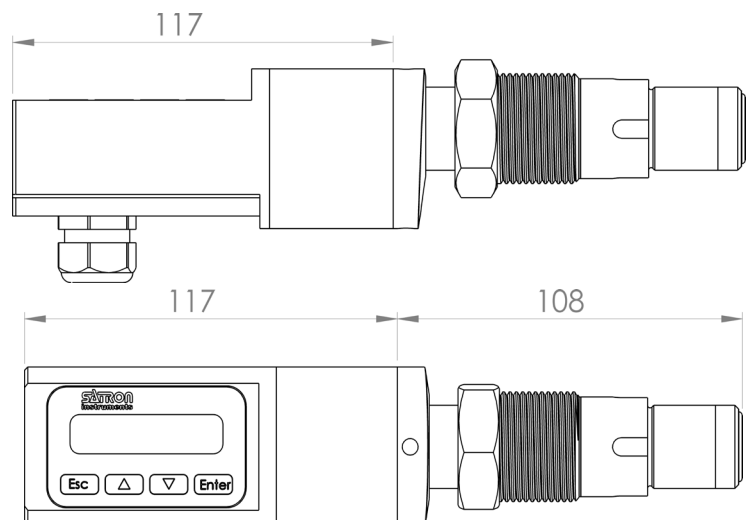

SATRON VG Flush Mount Pressure Transmitter

Explosion proof

Housings M, H and N can be ordered with ATEX explosion proof. Housing T is not available as ATEX-model.

Housing M has the highest equipment group rating Ex II 1 GD T135 °C

Housing H and N are Ex II 2 GD T135 °C. Housing N ATEX transmitters with display are with pushbuttons

Process temperature limits

The standard version of the VG has process temperature limits between -30 and +125 °C, the high temperature version can endure process temperatures from 0 to +200 °C. See graph on the right for details of the recommended temperature limits.

The high temperature version is 40 mm longer than the standard version. High temperature transmitter is available with all housing types and with silicon or inert oil filling.

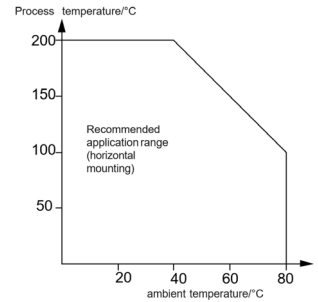

SPECIAL OPTIONS

Remote electronics options

If the environment is harsh or there are a lot of vibrations, remote electronics option helps to extend the lifetime of the transmitter. Remote electronics are available with straight (option L) or 90° angled sensor head (option K).

Connecting cable is protected with PTFE tube with AISI braiding. Cable length is available from 2 meters up to 10 meters. The mounting plate for the transmitter is included.

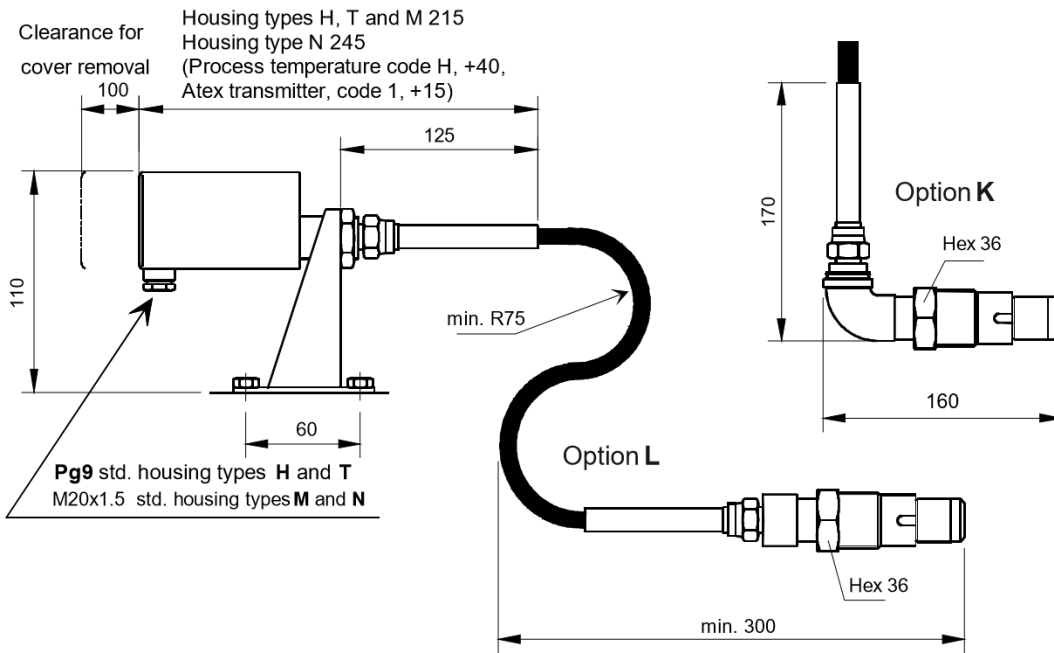

Special size of electrical inlet

Every housing type has their own standard electrical inlet. If different type of inlet is needed it is specified with this option.

Three different inlets are available: 1/2 NPT, Pg13.5 and DIN 43650 plug connector.

If standard inlet is used no specification for the inlet is needed.

TECHNICAL SPECIFICATIONS

Measuring range and span

See Selection chart on last page

Temperature limits

Ambient: -20 to +80 °C

Unit display: 0 to +50 °C (does not affect the operation of the transmitter)

Process:

Standard version:

-20 to +125 °C

High temperature version:

0 to +200 °C

Shipping and storage: -40 to +80 °C

Humidity limits

0-100% RH, freezing of condensed water not allowed in reference pressure channels.

Output

2-wire (2W), 4-20 mA

User selectable for linear, square root or inverted signal or transfer function (16 points) specified by the user.

Volumetric displacement

< 0.5 mm³/max.span

Pressure limits

Maximum process pressure (MPa)

Transmitter type	Max. overload pressure	Pressure class
VG3	0.2	PN40
VG4	0.3	PN40
VG5	1.5	PN40
VG6	7.5	PN100
VG7	40.0	PN250
VG8	100.0	PN250

Minimum process pressure

T _{process} (°C)	Minimum pressure for fill fluid (kPa, abs.)	
	DC200, 100 cSt	Inert oil
20	5	8
40	8	10
80	16	28
120	21	53

Zero and Span adjustment

Zero elevation: Calibrated span is freely selectable on the specified range. Adjustment can be made by using external control shaft, keyboard (transmitters with display option), HART@275/375/475 communicator or with Satron SI-tool.

Damping

Time constant continuously adjustable from 0.01 to 60 s.

Supply voltage and permissible load

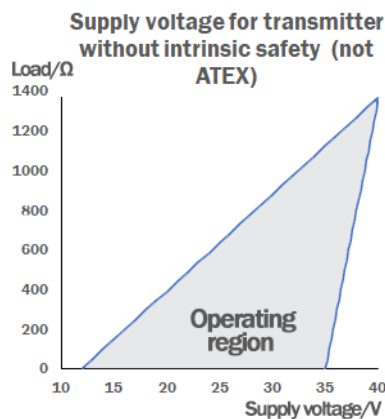

CONSTRUCTION AND CALIBRATION

Materials

see following pages

Filling fluid

Silicone oil (VG3-VG8) or inert oil (VG3-VG7)

Enclosure Protection class

IP66

Weight

Transmitter

- with housing types H and T, 0.7 kg
- with housing types M and N, 1.2 kg

PERFORMANCE SPECIFICATIONS

Tested in accordance with IEC 60770:

Reference conditions, specified span, no range elevation, horizontal mounting, AISI 316L diaphragm with process connection 4, silicone oil fill, mounting as instructed in manual.

Other options may affect the performance

Accuracy

(incl. nonlinearity, hysteresis and repeatability)

±0.05% of calibrated span

(span 1:1-5:1 / max range)

For measuring ranges 5:1-100:1:

$\pm[0.025+0.01 \times (\frac{\text{max. span}}{\text{calibrated span}})]\%$ of calibrated span

Temperature effect on compensated temperature ranges -20...+80 °C

Process temperature

Zero and span shift: ±0.15% of max. span

Long-term stability

±0.1% / max. span / 12 months

Mounting position effect

Zero error < 0.32 kPa, can be calibrated out

Vibration effect

According to IEC 68-2-6: FC

±0.1% of measuring range/

2g/10 to 2000 Hz

4g/10 to 100 Hz

Power supply effect

< ±0.01 of calibrated span / V

Insulation test voltage

500 V rms, 50 Hz

WIRING DIAGRAMS

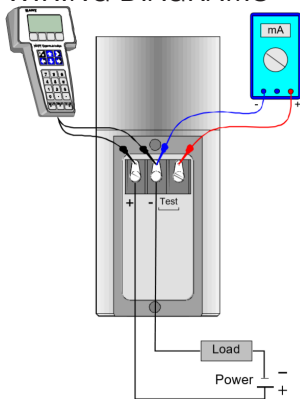

Housing with terminal strip and display, housing N

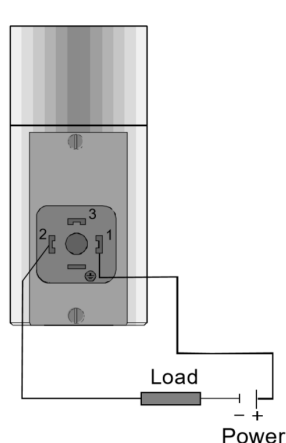

Housing with terminal strip and display with DIN 43650 plug connector, housing N with special electrical inlet P

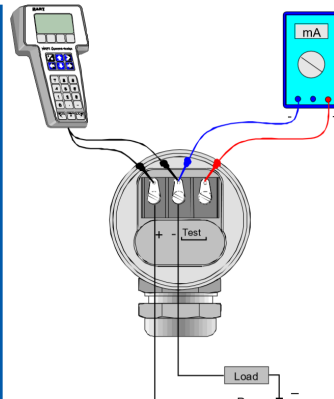

Housing with terminal strip, housing M

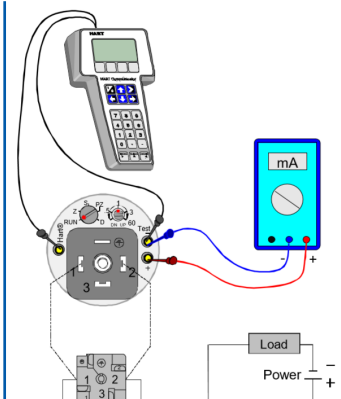

Housing with DIN43650 plug connector, housings H and T

COUPLINGS

examples only, several other thread and flange sizes and types are available, see VG Couplings brochure for details

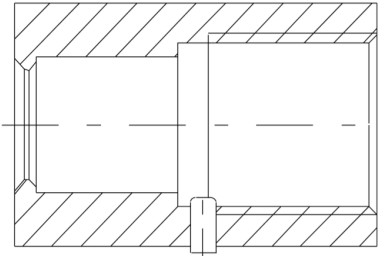

Standard coupling G1

Material	Product code
AISI316L	M546197
Duplex	M5461978
Hastelloy C276	M5461973
Titanium	M5461976

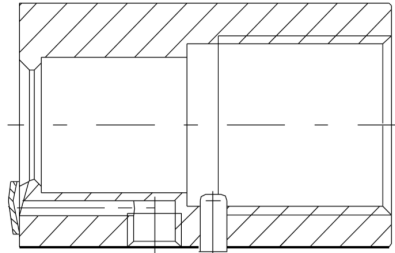

Standard coupling G1 with cleaning

Material	Product code
AISI316L	M1050020
Duplex	M10500208
Hastelloy C276	M10500203
Titanium	M10500206

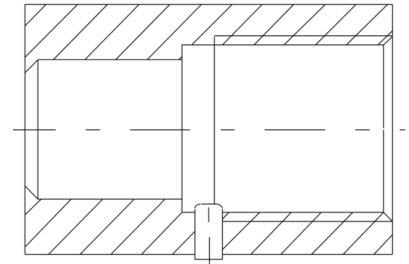

Hygienic coupling G1

Material	Product code
AISI316L	M548101
Duplex	M5481018
Hastelloy C276	M548102
Titanium	M548103

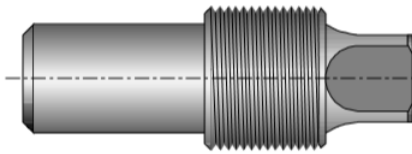

Welding assistant for Satron coupling G1, brass

Product code: M1050420



PTFE seal for metal/metal taper on Satron coupling G1

Product code: T546022



Special adapter for Satron coupling G1 Duplex adapter for installing the sensor head into the coupling (3mm depth)
Product code: M1050294

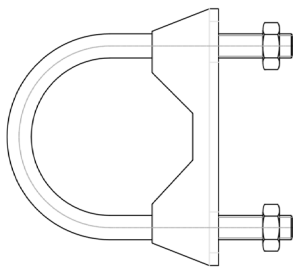

Mounting parts for K/L option mounting plate on a pipe, includes 2 x parts in picture

M10504025 for Ø 51 mm pipe
M10504025-1 for Ø 60 mm pipe

SATRON VG Flush Mount Pressure Transmitter

BPLV700
17.03.2022
Rev 5.1

SELECTION CHART

Sensor	Span, min	Span, max	Measuring range
VG3	4 kPa (40 mbar/0.58psi)	35 kPa (350 mbar/5.08psi)	-35...+35 kPa (-350...+350 mbar/-5.08...+5.08psi)
VG4	4 kPa (40 mbar/0.58psi)	100 kPa (1000 mbar/14.5psi)	-100...+100 kPa (-1000...1000 mbar/-14.5...+14.5psi)
VG5	10 kPa (100 mbar/1.45psi)	500 kPa (5000 mbar/72.5psi)	-100...+500 kPa (-1000...5000 mbar/-14.5...72.5psi)
VGA5	10 kPa (100 mbar/1.45psi)	500 kPa (5000 mbar/72.5psi)	0...+500 kPa (0...5000 mbar/0...72.5psi), abs.
VG6	0.03 MPa (0.3 bar/4.35psi)	3 MPa (30 bar/435psi)	-0.1...+3 MPa (-1...+30 bar/-14.5...435psi)
VGA6	0.03 MPa (0.3 bar/4.35psi)	3 MPa (30 bar/435psi)	0...+3 MPa (0...+30 bar/0...435psi), abs.
VG7	0.15 MPa (1.5 bar/21.76psi)	15 MPa (150 bar/2176psi)	0...+15 MPa (0...+150 bar/0...2176psi), abs.
VGS⁽⁴⁾	1 MPa (10 bar/145psi)	25 MPa (250 bar/3626psi)	-0.1...+25 MPa (-1...+250 bar/-14.7...3626psi)

Output **S** 4-20 mA DC/HART®-protocol

Process connection

4 Metal/metal taper **5** O-ring FPM⁽⁵⁾ **6** O-ring EPDM^(1,5)

Wetted material (Diaphragm)

2 AISI316 L
3 Hastelloy® C276⁽²⁾
5 Tantalum⁽²⁾
6 Titanium Gr2⁽²⁾
8 Duplex

Diaphragm coating (specify only if coated)

9 Gold/Rhodium
Y Diamond

Fill fluid **S** Silicone oil **G** Inert oil for oxygen use

Housing type

H Housing with PLUG connector DIN43650, no display, electrical inlet PG9 cable gland
T Housing with PLUG connector, manual adjust, DIN43650, no display, electrical inlet PG9, no ATEX
M Housing with junction box/terminal strip, no display, electrical inlet M20x1.5 cable gland
N Housing with junction box/terminal strip, with display, electrical inlet M20x1.5 cable gland

Explosion proof

0 No Explosion proof classification **1** ATEX Intrinsic safety  II 1 GD 135 °C⁽²⁾

Process temperature limits

N -20...+125 °C (-4...+257 °F) **H** 0...+200 °C (32...+392 °F)

Optional items: / / /

Example code of basic transmitter VG5 S 4 2 SNON

VG5 S 4 2 S N O N

Optional items and features, specify only if necessary:

Remote electronics

Connecting cable with protection hose

L Hose protected with PTFE/AISI316 braiding, straight
K Hose protected with PTFE/AISI316 braiding, 90° angle

Length of connection cable

2 2 m cable **3** 3 m cable etc. (max length 10 m)

Special size of electrical inlet

N ½ NPT **G** Pg13.5 **P** Plug DIN 43650

Material certificates

MC1 Raw material certificate without appendices, in accordance with SFS-EN 10204-2.1 (DIN 50049-2.1) standard
MC2 Raw material certificate for wetted parts, in accordance with SFS-EN 10204-2.2 (DIN 50049-2.2) standard
MC3 Raw material certificate for wetted parts, in accordance with SFS-EN 10204-3.1 B (DIN 50049-3.1 B) standard

Example code of transmitter with remote electronics and material certificate VG5 S 4 2 SNON L2 MC3

VG5 S 4 2 S N O N Optional items: / L 2 / / MC3

Rights reserved for technical modifications without prior notice

¹EHDG and 3A certified in AISI 316 L

²Housing H and N:  II 2 GD T135 °C

³Only for Process temperature limit "N" -20...+125 °C

⁴Only available in combination with Duplex

⁵Only up to 30bar

Hastelloy® is a registered trademark of Haynes International
HART® is a registered trademark of HART Communication Foundation
Viton® is a registered trademark of DuPont Down Elastomers
PASVE® is a registered trademark of Satron Instruments Inc.

