

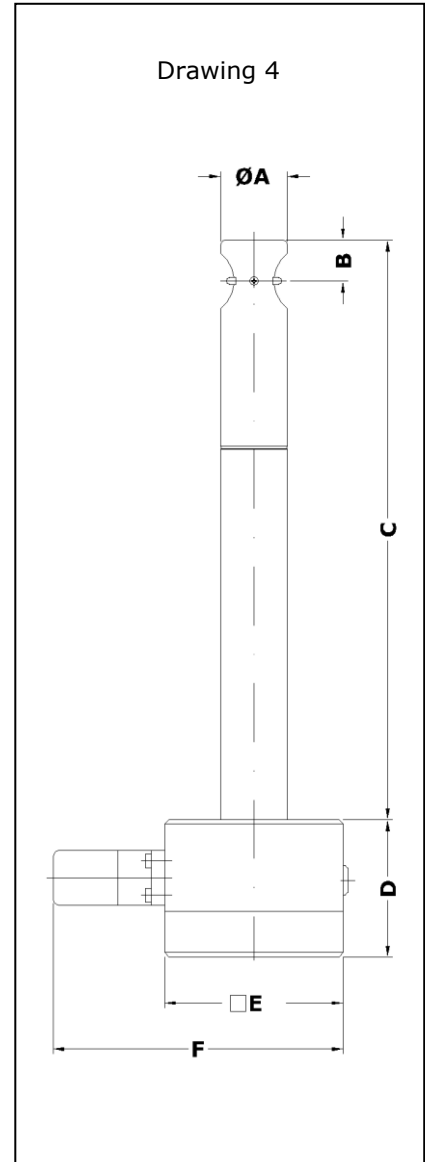

**Flow measurement with sensors ZS25
at working temperatures up to +500 °C
optional with integrated and configurable transducer UFA**



Vane wheel flow sensor ZS25
(see Page 3 for dimensions)

Measurable variable

- (actual) flow velocity v [m/s] and
- (actual) flow rate [m³/h] in air/gases and water/liquids
- conversion to standard velocity/standard volume flow with input parameters pressure and temperature

Measuring ranges

- 0.4 ... 120 m/s air/gases
- 0.04 ... 10 m/s water/liquids

Functional principle

- vane wheel flow sensor
- scanning the vane rotation; non-contact inductive proximity switch

Design

- insertion probe with AS80 housing

Media

- air, gas mixtures and clean gases
- water/liquids with viscosities up to 200 cSt

Advantages

- low starting value
- large measuring range span
- maximum fatigue strength thanks to vane wheel which is easy on the bearings
- corrosion resistant
- sterilisable
- high working temperature and pressure ranges
- accurate values even in varying and/or unknown gas compositions
- low pressure drop
- easy adjustment to process parameter
- compact unit with optional local display

Range and examples of application

- flow rate measuring, e.g. of air, exhaust gas, process gas
- monitoring flow in pharmaceutical works
- monitoring neutralisation processes
- monitoring laminar flow
- measuring in non-conductive liquids such as ultra pure water, for example in the semiconductor industry

Particles and humidity

- particles may restrict the fatigue strength of the vane wheel set
- relative gas humidity of less than 100 % does not affect the measurement uncertainty



Model designation (example)

ZS25/25	-350	GF	E	350	p10	Ex	ZG4
(1)	(2)	(3)	(4)	(5)	(6)	(7)	(8)

Basic types

Type	Transducer/ Output	Article No.
'100 °C' / integrated UFA		
ZS25/25- 250 GFE/100/p10/ZG4	UFA-int / 4-20 mA	B002/190-UFA
ZS25/25- 350 GFE/100/p10/ZG4	UFA-int / 4-20 mA	B002/191-UFA
ZS25/25- 450 GFE/100/p10/ZG4	UFA-int / 4-20 mA	B002/192-UFA
ZS25/25- 550 GFE/100/p10/ZG4	UFA-int / 4-20 mA	B002/193-UFA
ZS25/25- 650 GFE/100/p10/ZG4	UFA-int / 4-20 mA	B002/194-UFA
'260 °C' / integrated UFA		
ZS25/25- 250 GFE/260/p10/ZG4	UFA-int / 4-20 mA	B002/195-UFA
ZS25/25- 350 GFE/260/p10/ZG4	UFA-int / 4-20 mA	B002/196-UFA
ZS25/25- 450 GFE/260/p10/ZG4	UFA-int / 4-20 mA	B002/197-UFA
ZS25/25- 550 GFE/260/p10/ZG4	UFA-int / 4-20 mA	B002/198-UFA
ZS25/25- 650 GFE/260/p10/ZG4	UFA-int / 4-20 mA	B002/199-UFA
'370 °C' / integrated UFA		
ZS25/25- 250 GFE/370/p10/ZG4	UFA-int / 4-20 mA	B002/200-UFA
ZS25/25- 350 GFE/370/p10/ZG4	UFA-int / 4-20 mA	B002/201-UFA
ZS25/25- 450 GFE/370/p10/ZG4	UFA-int / 4-20 mA	B002/202-UFA
ZS25/25- 550 GFE/370/p10/ZG4	UFA-int / 4-20 mA	B002/203-UFA
ZS25/25- 650 GFE/370/p10/ZG4	UFA-int / 4-20 mA	B002/204-UFA
'500 °C' / integrated UFA		
ZS25/25- 250 GFE/500/p10/ZG4	UFA-int / 4-20 mA	B002/205-UFA
ZS25/25- 350 GFE/500/p10/ZG4	UFA-int / 4-20 mA	B002/206-UFA
ZS25/25- 450 GFE/500/p10/ZG4	UFA-int / 4-20 mA	B002/207-UFA
ZS25/25- 550 GFE/500/p10/ZG4	UFA-int / 4-20 mA	B002/208-UFA
ZS25/25- 650 GFE/500/p10/ZG4	UFA-int / 4-20 mA	B002/209-UFA
'100 °C' / separate evaluation unit		
ZS25/25- 250 GFE/100/p10/ZG4	sep. eval. unit / v/FA	B002/190
ZS25/25- 350 GFE/100/p10/ZG4	sep. eval. unit / v/FA	B002/191
ZS25/25- 450 GFE/100/p10/ZG4	sep. eval. unit / v/FA	B002/192
ZS25/25- 550 GFE/100/p10/ZG4	sep. eval. unit / v/FA	B002/193
ZS25/25- 650 GFE/100/p10/ZG4	sep. eval. unit / v/FA	B002/194
'260 °C' / separate evaluation unit		
ZS25/25- 250 GFE/260/p10/ZG4	sep. eval. unit / v/FA	B002/195
ZS25/25- 350 GFE/260/p10/ZG4	sep. eval. unit / v/FA	B002/196
ZS25/25- 450 GFE/260/p10/ZG4	sep. eval. unit / v/FA	B002/197
ZS25/25- 550 GFE/260/p10/ZG4	sep. eval. unit / v/FA	B002/198
ZS25/25- 650 GFE/260/p10/ZG4	sep. eval. unit / v/FA	B002/199

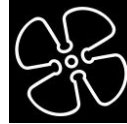

Basic types (cont.)

Type	Transducer/ output	Article no.
'370 °C' / separate evaluation unit		
ZS25/25- 250 GFE/370/p10/ZG4	sep. eval. unit / v/FA	B002/200
ZS25/25- 350 GFE/370/p10/ZG4	sep. eval. unit / v/FA	B002/201
ZS25/25- 450 GFE/370/p10/ZG4	sep. eval. unit / v/FA	B002/202
ZS25/25- 550 GFE/370/p10/ZG4	sep. eval. unit / v/FA	B002/203
ZS25/25- 650 GFE/370/p10/ZG4	sep. eval. unit / v/FA	B002/204
'500 °C' / separate evaluation unit		
ZS25/25- 250 GFE/500/p10/ZG4	sep. eval. unit / v/FA	B002/205
ZS25/25- 350 GFE/500/p10/ZG4	sep. eval. unit / v/FA	B002/206
ZS25/25- 450 GFE/500/p10/ZG4	sep. eval. unit / v/FA	B002/207
ZS25/25- 550 GFE/500/p10/ZG4	sep. eval. unit / v/FA	B002/208
ZS25/25- 650 GFE/500/p10/ZG4	sep. eval. unit / v/FA	B002/209

(1) Sensor type / Sensor diameter

Vane wheel flow sensor ZS25 with sensor Ø 25 mm and shaft Ø 25 mm

(2) Sensor length dimension C (see Drawing 4, Page 1)

250 / 350 / 450 / 550 / 650 mm

(3) Medium

... GF ... air/gases and water/liquids

(4) Materials in contact with the medium

Design	Material
... E ...	stainless steel 1.4404 / AISI 316L, ceramics Al ₂ O ₃ 99.9 % design '100 °C': VITON®, PTFE seal design '260 °C': PTFE seal design '370 °C' and '500 °C': pure graphite seal

(5) Permissible temperature of the medium

Design	Temperature of the medium
... 100 ...	-20 ... +100 °C (continuous)
... 260 ...	-40 ... +260 °C (continuous) -40 ... +300 °C (short-time)
... 370 ...	-40 ... +370 °C (continuous) -40 ... +400 °C (short-time)
... 500 ...	-40 ... +500 °C (continuous) -40 ... +550 °C (short-time)

ambience	-40 ... +80 °C	with separate evaluation unit
	-40 ... +80 °C	with integrated transducer UFA-int
	-5 ... +50 °C	with optional 'LCD display'

(6) Max. working pressure / Type of protection for sensor

up to 10 bar / 1 MPa kPa above atmospheric
protection class IP68

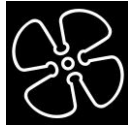

(7) Option 'Ex'

Type of protection	Art. No.	Comment
Ex nA IIC T6 Gc X Gas-Ex: Category 3G (Zone 2)	FAEX2	only in connection with: <ul style="list-style-type: none"> evaluation unit
Ex tc IIIC TX Dc X Dust-Ex: Category 3D (Zone 22)	FAEX2	only in connection with: <ul style="list-style-type: none"> evaluation unit
Ex ia IIC T6 Gas-Ex: Category 2G (Zone 1)	FAEX1	only in connection with: <ul style="list-style-type: none"> isolation/supply unit LDX2 <u>and</u> 'non-Ex evaluation unit or compatible separate evaluation unit with Ex-output

(8) Design

as in Drawing 4 (Page 1)

dimensions	A Ø 25 mm	B 13.9 mm	C 250/350/450/550/650 mm
	D 60 mm	E 80 mm	F 130 mm

Measuring range / vane wheel type

Measuring range air/gases*	Measuring range water/liquids**	Vane wheel type	Article No.
with 'stainless steel' probe			
0.4 ... 20 m/s	0.04 ... 7.5 m/s	mn 20 E	V_MN20GFE
0.5 ... 40 m/s	0.05 ... 10 m/s	mn 40 E	V_MN40GFE
1.0 ... 80 m/s	0.08 ... 10 m/s	mn 80 E	V_MN80GFE
1.4 ... 120 m/s	0.10 ... 10 m/s	mn 120 E	V_MN120GFE

Measurement uncertainty for air/gases and water : < 1.5 % of measured value + 0.5 % FS

Repeatability for air/gases and water : ±(0.05 % FS + 0.02 m/s)

* with an air/gas density of approx. 1.2 kg/m³

** the specified measuring ranges for applications in liquids are only practicable as long as there is no cavitation around the vane wheel

Connection housing AS80

dimensions	80 / 80 / 60 mm (L / W / H)
connection	connector GO 070 with terminal screws
terminal assignment	see Page 6
protection class	IP65

Output / transducer (see Pages 2 & 3, 'Basic types')

output 4-20 mA / integrated UFA	UFA integrated in the housing (see Page 6)
output sensor v/FA / separate evaluation unit necessary	Höntzsch evaluation unit with v/FA input necessary for signal evaluation
output sensor v/FA-Ex, sensor with option 'Ex' for use in Category 2G (Zone1) / sep. eval. unit necessary	Höntzsch evaluation unit with intrinsically safe v/FA-Ex signal input or with v/FA input in conjunction with a series connected isolation/supply unit necessary for signal evaluation



Accessories		
	Description	Article no.
	calibration certificate v/FA	KLB
probe guide piece SFB 25 E-70 / F-DN50 PN16 ZG1 for max. +550 °C as in drawing 1	for any repeated positioning with lower pressures above atmospheric (max. 2 bar / 200 kPa) / subatmospheric pressures, working temperature range -40 ... +550°C, through hole 25 mm, to single ended flange nipples or ball valve with flange, probe attachment by clamping bush, materials: stainless steel, graphite, flange DN50 PN16 in conformity with DIN, installation length L 70 mm	B004/110
probe guide piece SFK 25 E-50 / G 1 1/4" ZG2 with clamping yoke as in drawing 2	for any repeated positioning even with higher excess pressure (max. 10 bar/1 MPa) / low pressure, through hole 25 mm, connection by screw thread sleeve or ball valve inside thread G 1 1/4", working temp. range -20 ... +240 °C, installation length 50 mm, materials: stainless steel, VITON® lip-seal, VITON® O-ring	B004/211
probe guide piece SFB 25 E-54 / G 1 1/4" ZG5 with clamping bush as in drawing 5	for any repeated positioning with marginal excess pressure (max. 2 bar/ 200 kPa) / low pressure, through hole 25 mm, connection by screw thread sleeve or ball valve with inside thread G 1 1/4", working temp. range -20 ... +240 °C, installation length 54 mm, materials: stainless steel, VITON®, PTFE clamping bush	B004/510

Probe guide piece drawing 1

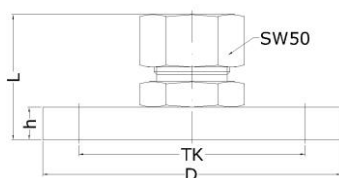

Probe guide piece drawing 2

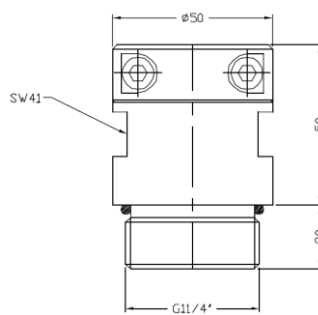

Probe guide piece drawing 5

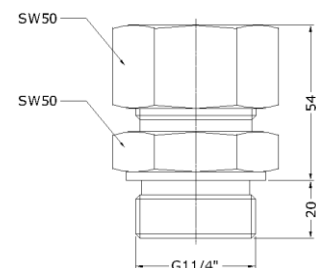

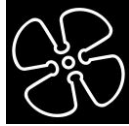

Transducer UFA-int, integrated in the sensor connection housing

analog output/resistance	4 ... 20 mA = 0 ... ___ m/s, resistance max. 400 Ohm
output 'limit value' or 'quantity pulse'	Open Collector / max. 50 mA / max. 27 V DC, pulse duration 0.5 s
PC interface	RS232
self-monitoring	output signals electrically isolated from the power supply parameter settings, sensor interface; in case of error: analog output less than 3.6 mA
connection	connector GO 070 with terminal screws
power supply	24 V DC (20 ... 27 V DC)
power consumption	less than 3 W
working temp. range	-40 ... +80 °C
housing	sensor connection housing AS80
EMC	EN 61 000-6-2
setting parameter	analog output, profile factor/coefficient, pipe inside diameter, time constant, sensor type, measurement range, medium, limit value or quantity pulse (valency adjustable), switching actual/standard flow with setting parameters, 'actual pressure' and 'actual temperature' ...
setting parameter with PC software UCOM and programming adapter (see below) changeable	

Accessories (cont.) / options

	Description	Art. No.
LCD display in housing cover	2 x 16 digit, numerals 3 mm high, working temperature range -5...+50 °C	A010/007
PC software UCOM	for configuring the UFA/int via RS232	A010/052
programming adapter G0 070 / RS232	for software UCOM, connection PC Sub-D 9-pin, power plug 230VAC/24VDC	A010/004
interface converter USB / RS232	PC connection : USB plug type A on instrument : Sub-D 9-pin	A010/100



optional LCD display in the housing cover

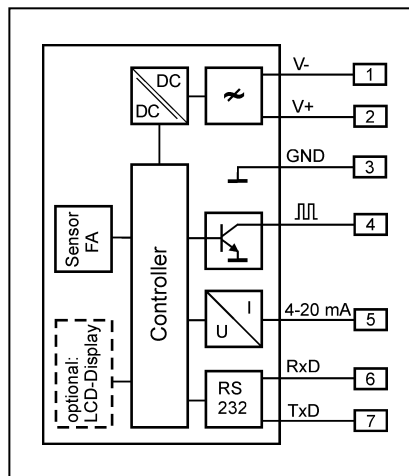

Wiring diagram with integrated UFA

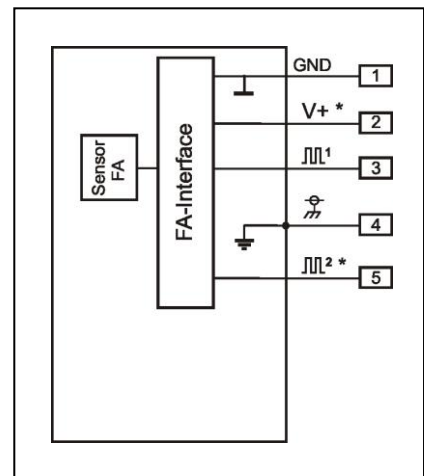

Wiring diagram sensor for separate evaluation unit (* optional)