



Sensor TA Di with integrated transducer U10b

**Functional principle**

Measurement of flow according to the heat transfer method

**Measured variables**

- standard velocity, standard flow rate, mass flow and temperature
- standard conditions adjustable; default:  
temperature  $t_n = +21\text{ °C}$   
pressure  $p_n = 1014\text{ hPa}$

**Gases**

- pure gases, gas mixtures: air, nitrogen, methane, natural gas, propane, butane, argon, carbon dioxide, sulphur hexafluoride, helium, hydrogen, oxygen, landfill gas, ...
- switching between the calibration characteristics of various measurement gases is possible in running operation

**Output variables**

- 2 analog outputs 4 ... 20 mA (flow and temperature)
- quantity pulse / limit value
- performance data via WiFi
- M-Bus

**Design**

Measuring tube with transducer integrated in the connection housing

**Advantages**

- high turndown ratio (up to 1 : 1000)
- measuring range from 0.04 Sm<sup>3</sup>/h (0.6 Sl/min)
- low measuring uncertainty, even at lowest flow velocities
- direct mass flow measurement; additional pressure and temperature measuring is not necessary
- sensor has no moving parts
- stainless steel sensor housing
- higher working temperature and pressure ranges
- low installation costs
- negligible pressure drop thanks to virtually unrestricted passageway
- high durability and long-term stability
- sterilisable (sensor material resistance allowing)
- optional: LCD with keypad, WiFi, M-Bus
- values can be displayed and parameters set simply via the display and keypad or web interface

**Range and examples of application**

- measuring
  - compressed air and gas consumption of oxygen, nitrogen, argon e.g. in welding technologies
  - leakage flow
  - outgoing air, burner supply air
  - monitoring inerting of nuclear processes
  - in air in low vacuum range at pressures greater than 200 hPa abs.

**Particles, condensation, humidity in the gas**

- charges in the gas caused by particles, dust and fibres do not affect the measurement as long as there is no abrasion and no deposit on the sensor
- deviations in values as a result of variable air humidity in normal atmospheric conditions are covered by the measuring uncertainty specifications

### Model designation (example)

<b>TA Di</b>	<b>8</b>	<b>G</b>	<b>E</b>	<b>60 m/s</b>	<b>140</b>	<b>p16</b>	<b>ZG3d</b>
(1)	(2)	(3)	(4)	(5)	(6)	(7)	(8)

### Basic types

Type	Article no.
TA Di 8 GE 60 m/s / 140 / p16 ZG3d	B016/510
TA Di 8 GE 120 m/s / 140 / p16 ZG3d	B016/510-120M/S
TA Di 8 GE 150 m/s / 140 / p16 ZG3d	B016/510-150M/S
TA Di 16 GE 60 m/s / 140 / p16 ZG1d	B016/511
TA Di 16 GE 120 m/s / 140 / p16 ZG1d	B016/511-120M/S
TA Di 16 GE 150 m/s / 140 / p16 ZG1d	B016/511-150M/S
TA Di 21.6 GE 60 m/s / 140 / p16 ZG1d	B016/512
TA Di 21.6 GE 120 m/s / 140 / p16 ZG1d	B016/512-120M/S
TA Di 21.6 GE 150 m/s / 140 / p16 ZG1d	B016/512-150M/S
TA Di 27.2 GE 60 m/s / 140 / p16 ZG1d	B016/513
TA Di 27.2 GE 120 m/s / 140 / p16 ZG1d	B016/513-120M/S
TA Di 27.2 GE 150 m/s / 140 / p16 ZG1d	B016/513-150M/S
TA Di 35.9 GE 60 m/s / 140 / p16 ZG1d	B016/514
TA Di 35.9 GE 120 m/s / 140 / p16 ZG1d	B016/514-120M/S
TA Di 35.9 GE 150 m/s / 140 / p16 ZG1d	B016/514-150M/S
TA Di 41.8 GE 60 m/s / 140 / p16 ZG1d	B016/515
TA Di 41.8 GE 120 m/s / 140 / p16 ZG1d	B016/515-120M/S
TA Di 41.8 GE 150 m/s / 140 / p16 ZG1d	B016/515-150M/S

### (1) Sensor type / design

Thermal flow sensor TA Di designed as measuring tube

### (2) Dimensions

measuring tube inside diameter $\varnothing$ Di [mm]	installation length L [mm]	installation height h [mm]	tube connection on both sides
8.0	80 mm + SRV *	95	via on-site tubes 12 x 2 mm
16.0	480	95	Ag R 1/2" ** Gg RP 1/2"
21.6	650	100	Ag R 3/4" ** Gg RP 3/4"
27.2	820	100	Ag R 1" ** Gg RP 1"
35.9	1080	100	Ag R 1 1/4" ** Gg RP 1 1/4"
41.8	1250	105	Ag R 1 1/2" ** Gg RP 1 1/2"

\* **SRV** : mechanical joint on both sides

\*\* **Ag** : Whitworth tapered pipe thread according to DIN 2999

**Gg** : counter thread

### Input/output section

to be provided for TA Di 8 on site - tubes 12 x 2 mm, 160 mm (input) / 80 mm (output) laid straight; no additional input/output section necessary for other measuring tubes; length of input section 2/3 of installation length L and output section 1/3 of installation length L

**(3) Measuring gases**

air, clean gases, gas mixtures with constant ratio of mixture

**(4) Materials in contact with the medium**

stainless steel 1.4571, 1.4305, 1.4404, glass, epoxy resin, silicone (silicone-free on request), Viton®

**(5) Measuring ranges\* air/nitrogen**

basic types / measuring range	in m <sup>3</sup> /h	in kg/h	in l/min	in m/s	1 m <sup>3</sup> /h equates to [m/s]
<b>TA Di 8 ...</b>					
... 60 m/s ...	0.04 ... 11	0.05 ... 13	0.6 ... 181	0.2 ... 60	5.53
... 120 m/s ...	0.04 ... 22	0.05 ... 26	0.6 ... 362	0.2 ... 120	5.53
... 150 m/s ...	0.04 ... 27	0.05 ... 33	0.6 ... 452	0.2 ... 150	5.53
<b>TA Di 16 ...</b>					
... 60 m/s ...	0.15 ... 43	0.18 ... 52	2.4 ... 729	0.2 ... 60	1.38
... 120 m/s ...	0.15 ... 86	0.18 ... 104	2.4 ... 1448	0.2 ... 120	1.38
... 150 m/s ...	0.15 ... 109	0.18 ... 130	2.4 ... 1810	0.2 ... 150	1.38
<b>TA Di 21.6 ...</b>					
... 60 m/s ...	0.27 ... 79	0.32 ... 95	4.4 ... 1319	0.2 ... 60	0.758
... 120 m/s ...	0.27 ... 158	0.32 ... 190	4.4 ... 2638	0.2 ... 120	0.758
... 150 m/s ...	0.27 ... 198	0.32 ... 238	4.4 ... 3298	0.2 ... 150	0.758
<b>TA Di 27.2 ...</b>					
... 60 m/s ...	0.42 ... 125	0.50 ... 151	7.0 ... 2092	0.2 ... 60	0.478
... 120 m/s ...	0.42 ... 250	0.50 ... 300	7.0 ... 4184	0.2 ... 120	0.478
... 150 m/s ...	0.42 ... 314	0.50 ... 377	7.0 ... 5230	0.2 ... 150	0.478
<b>TA Di 35.9 ...</b>					
... 60 m/s ...	0.73 ... 219	0.88 ... 263	12.1 ... 3644	0.2 ... 60	0.274
... 120 m/s ...	0.73 ... 438	0.88 ... 526	12.1 ... 7288	0.2 ... 120	0.274
... 150 m/s ...	0.73 ... 547	0.88 ... 657	12.1 ... 9110	0.2 ... 150	0.274
<b>TA Di 41.8 ...</b>					
... 60 m/s ...	1.0 ... 296	1.2 ... 356	16.5 ... 4949	0.2 ... 60	0.202
... 120 m/s ...	1.0 ... 592	1.2 ... 712	16.5 ... 9880	0.2 ... 120	0.202
... 150 m/s ...	1.0 ... 741	1.2 ... 890	16.5 ... 12350	0.2 ... 150	0.202

\* all standard flow rate and standard flow velocity specifications relating to a standard pressure  $p_N = 1014 \text{ hPa}$  and a standard temperature  $t_p = +21 \text{ °C}$  (294.15 K)

**Measurement uncertainty / damping**

measurement uncertainty for flow velocities  $S_v$  with 1014 hPa and +21 °C in air and gases, as far as calibration performed in real gas

less than / equal to 40 m/s: 2 % v. M. + 0.02 m/s

greater than 40 m/s : 2.5 % v. M.

damping : adjustable to 0.5 s and multiples

Measurable gases			
Medium	Calibration	Medium	Calibration
air	calibration in the medium	carbon dioxide (CO <sub>2</sub> )	transformed characteristics
nitrogen (N <sub>2</sub> )	transformed characteristics	landfill gas (40 % CH <sub>4</sub> )	transformed characteristics
argon (Ar)	transformed characteristics	helium (He)	transformed characteristics
methane (CH <sub>4</sub> )	transformed characteristics	hydrogen (H <sub>2</sub> )	transformed characteristics
propane (C <sub>3</sub> H <sub>8</sub> )	transformed characteristics	oxygen (O <sub>2</sub> )	transformed characteristics
butane (C <sub>4</sub> H <sub>10</sub> )	transformed characteristics	custom 1,2	customised calibrations

Calibration always performed in air, in addition, characteristics transformation for the listed media.

The media stored for the realisation of the smallest measurement uncertainties are generally also calibrated in real gas.

On request, additional calibration data for up to two further calibrations can be stored in other media or as special calibrations.

(6) Permissible temperature	
medium	-10 ... +140 °C
ambient	-25 ... +50 °C -20 ... +50 °C with option 'LCD'

(7) Pressure resistance	
max. 16 bar / 1.6 MPa above atmospheric	
greater than 16 bar / 1.6 MPa on request	

(8) Design	
TA Di 8	measuring tube with connection housing and integrated transducer U10b, according to Drawing 3d
TA Di 16 ... 41.8	measuring tube with connection housing and integrated transducer U10b, according to Drawing 1d

Drawing 1d

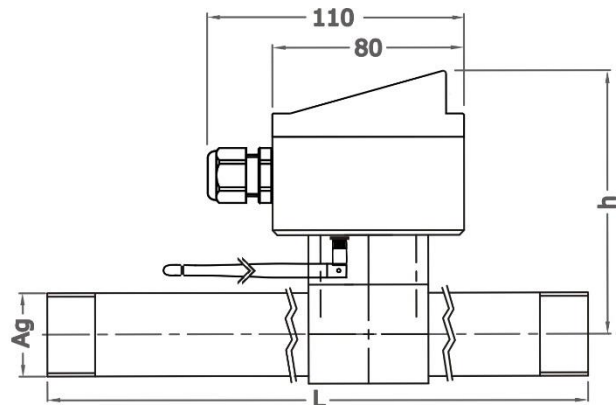
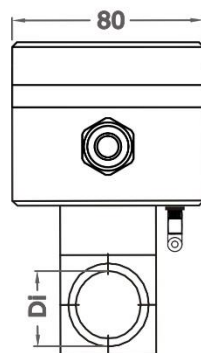

Drawing 3d

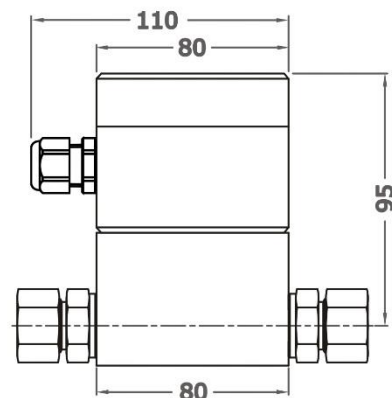
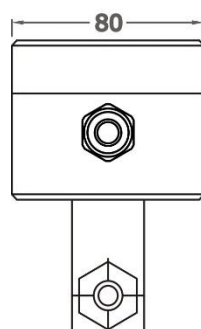

**Ingress protection / fitting position**

sensor IP68, IEC 529 and EN 60 529  
any installation position with atmospheric pressure,  
with pressures above atmospheric direction of flow not from above

**Connection housing AS80**

measurements	80 / 80 / 71 (60) mm (L / W / H)
connection	Cable gland for cables with an outside diameter 5 ... 9 mm, terminal clamps for strands with cross section 0.2 ... 1.5 mm <sup>2</sup> . Comply with the standards and regulations applicable to the cable routing.
protection class	IP65, IEC 529 and EN 60 529
Material	powder-coated aluminium

**Measuring transducer design U10b, integrated in the sensor connection housing**

analog output 1 flow or temperature	4 ... 20 mA (linear), update every 500 ms burden max. 500 Ohm
analog output 2 * flow or temperature	4 ... 20 mA (linear), update every 500 ms burden max. 500 Ohm
measured variable flow	Sm <sup>3</sup> /s, Sft/min, Scfm, Sl/s, Sl/min, Sl/h, Sm <sup>3</sup> /s, Sm <sup>3</sup> /min, Sm <sup>3</sup> /h and kg/h counter in Sm <sup>3</sup>
measured variable temperature	°C, °F
pulse output	for quantity measurement or as a limit value, open drain, max. 32 V, 20 mA, pulse duration 0.5 s, max. pulse frequency 1 Hz per volume unit SV, internal current limiting, thermal circuit breaker
power supply	24 V DC ± 10 %
power consumption	less than 3 W
housing	AS80
EMC	EN 61 000-6-2 and EN 61 000-6-4
setting parameter	physical variables, initial and final value of the analog outputs, time constants, profile factor, pipe inside diameter, quantity pulse, limit value, working pressure, standard density, WiFi settings and more parameters can be changed via display and keypad or web interface

\* Analog output 2 is not applicable, if sensor is designed with M-Bus option.

Options		
	Description	Article no.
local LCD with keypad and quantity counter	illuminated, in housing cover, multi-row, graphic-capable, temperature range -20 ... +50 °C, display options: <ul style="list-style-type: none"> <li>- instantaneous value (volume flow and temperature)</li> <li>- volume</li> <li>- graphical overview of the instantaneous values of the last 10 seconds</li> <li>- status information</li> </ul>	A010/530
WiFi module	compatible with the WLAN standards IEEE 802.11b/g/n (2.4 GHz), rotatable and pivotable round antenna. Permits parameter setting and display of the measured value course via web interface. Use as local hotspot or integration in the existing WLAN possible.	WIFI
ATEX type of protection category 3G and 3D (zone 2 and 22)	Ex ec IIC T4 Gc X * Ex tc IIIC T135 °C Dc X * * option display and keypad not possible	TAEX2E



Display and keypad (optional)



WiFi (optional)

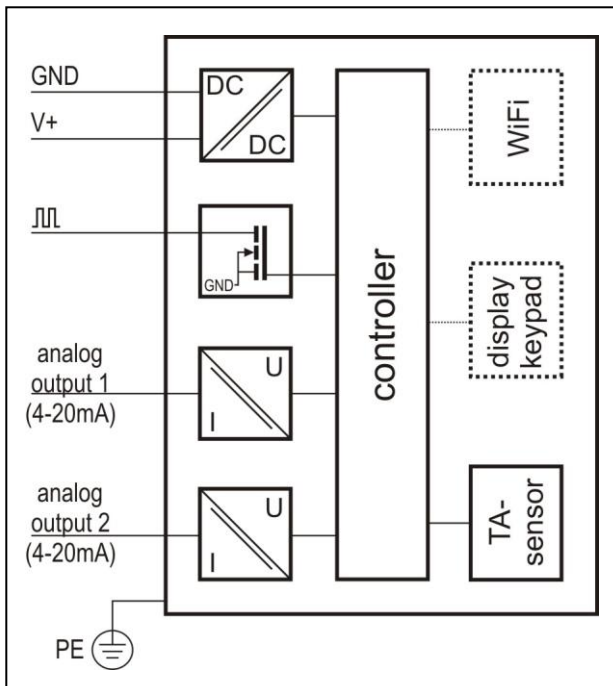

Wiring diagram U10b, standard

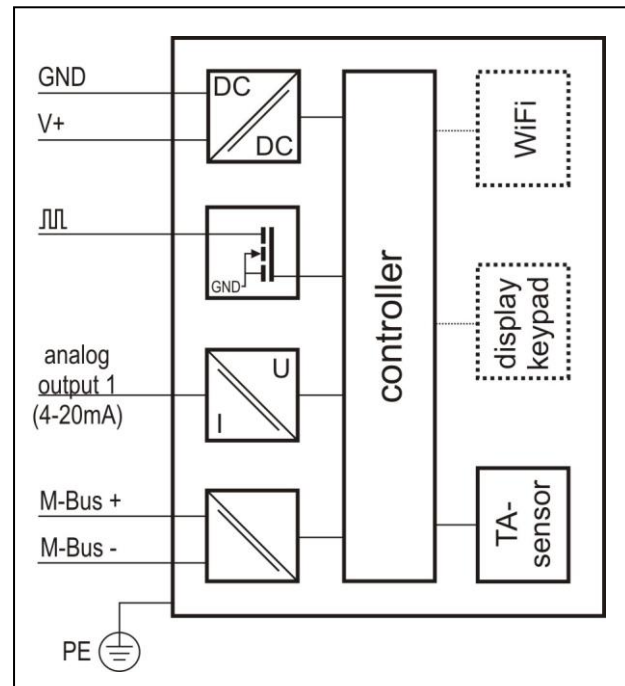

Wiring diagram U10b with M-Bus option

**M-Bus option**

	Description	Article no.
M-Bus option	M-Bus according to EN13757-2 and EN13757-3, measurable variables: SNI/s, SI/min, SI/h, Sm <sup>3</sup> /s, Sm <sup>3</sup> /min, Sm <sup>3</sup> /h and kg/h, as well as quantity counter in Sm <sup>3</sup> readable, bus address (0) and baud rate (2400) preset and alterable via M-Bus, galvanically isolated, Bus Load: 2 Unit Loads (3mA)	M-BUS OPTION
	Setting parameter: physical variables, baud rate, bus address, damping, profile factor, tube inside diameter, standard basis, standard density, working pressure, quantity pulse, limit value	

**Accessories**

	Description	Article no.
calibration certificate Sv	min. 6 standard calibration values	KLB