

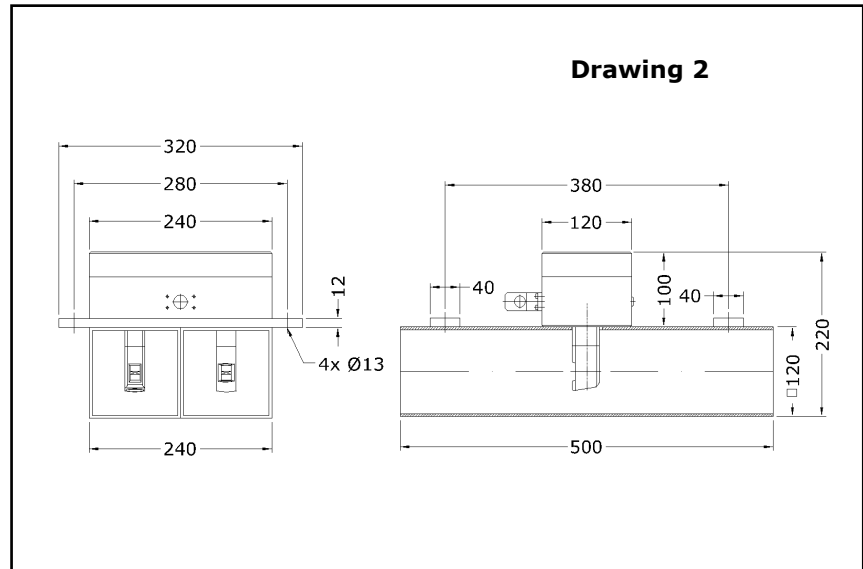

**Vortex flow sensor VAR TwinPipe with \pm directional sensing of flow
for measuring flow velocity in traffic tunnels, mining galleries and waste disposal sites**



Measurable variable

- standard flow velocity v [m/s]

Medium

- air, exhaust air ...

Range and examples of application

- measurement of flow in traffic tunnels, mines and waste disposal sites
- control of air ventilation

Measuring range

$\pm 0.4 \dots \pm 25$ m/s

Advantages

- cost-efficient
- robust, maintenance-free and nonwearing, as no moving parts
- high fatigue strength and long-term stability
- reliable, even in extreme conditions
- unlike other measuring systems no on site calibration necessary
- only one installation point for the entire measuring system necessary
- application in Ex-protection Category 3G and 3D (zone 2 and zone 22) permissible

Particles, humidity and condensation

- charges in the gas caused by particles such as soot do not affect measurements, as long as geometric-changing agglomerations do not occur on the sensor
- relative humidity of less than 100 % does not affect the measurement uncertainty

Functional principle

- vortex meter for measuring flow velocity
- ultrasonic measurement of the vortex shedding

Design

- vortex twin flow sensor



Design

type	art. no.
VAR40-500GE 25 m/s 80 °C / p0 ZG2	b009/697

Sensor type

Vortex VAR TwinPipe
for measuring flow velocity and the \pm direction of flow as in Drawing 2

Dimensions (see Drawing 2, Page 1) / weight

L / H / W	500 / 220 / 320 mm
Weight	approx. 19 kg

Medium

... G ...	air, exhaust air ... (gases)
-----------	------------------------------

Materials in contact with the medium

... E ...	stainless steel, sensor housing 1.4581, twin pipe 1.4571, PE-coated metallic silver, ceramics, sealing parts : silicone, connection housing : aluminium with corrosion-inhibiting lacquering
-----------	--

Measuring range

... 25 m/s ...	± 0.4 ... ± 25 m/s
calibration values	± 1 ; ± 2 ; ± 5 ; ± 10 ; ± 15 ; ± 20 ; ± 25 m/s
measurement uncertainty	< 1.5 % of measured value + 0.03 m/s
consistency	0.2 % of measured value + 0.025 % of terminal value

Permissible temperature of the medium

... +80 °C ...	temperature of the medium or ambient temperature -40 ... +80 °C (continuous)
----------------	---

Max. working pressure / degree of protection / EMC

approx. atmospheric pressure	
degree of protection	sensor IP68, connection housing IP67, as per IEC 529 and EN 60 529
EMC	EN 61 000-6-2

Design

as per Drawing 2 (see Page 1)



Connection housing AS124

dimensions	240 / 120 / 100 mm (L / W / H)
connection	cable socket GO 070 with screw-type terminals, for connecting cable with diameter 4 ... 10 mm and strand diameter 0.14 ... 0.5 mm ²
terminal pin assignment	see Page 4

Sensor mounting

4 vertical drill holes with 13 mm diameter (see Drawing 2 / Page 1)

Design as transducer UVA, integrated in the sensor connection housing

analog output v, flow velocity or flow rate	4 ... 20 mA* = 0 ... x m/s, with relay configuration (see below): \pm direction of flow alternative configurable: 4 ... 12 ... 20 mA = -x ... 0 ... +x m/s, terminal value x configurable / resistance max. 400 Ohm
output either limit value or \pm directional flow	relay (normally open contact with reference to 'GND' (system ground)), max. 300 mA / max. 27 V DC
* when choosing ' \pm direction of flow': analog output (see above) proportional to the absolute value v, without arithmetic sign	limit value (alternative 1, configurable): flow velocity < limit value: relay idle, flow velocity > limit value: relay in working position \pmdirection of flow v (alternative 2, configurable): +direction: relay idle, - direction: relay in working position
PC serial port RS232	for changing calibration data and parameter by the manufacturer, connection via GO 070 cable socket
self-monitoring	output signals are electrically isolated from the power supply parameter settings, sensor interface; with error: analog output less than 3.6 mA
power supply	24 V DC (20 ... 27 V DC)
power consumption	less than 5 W
setting parameter	analog output, time constant, profile factor, limit value ...
setting parameter may be modified (by the manufacturer) using UCOM software and programming adapter	

Accessories (optional)

	Description	art. no.
ATEX cat. 3G (zone 2)	Ex nA IIC T6 Gc	vaex2
ATEX cat. 3D (zone 22)	Ex tc IIIC TX Dc	
Calibration certificate v/VA		klbneu

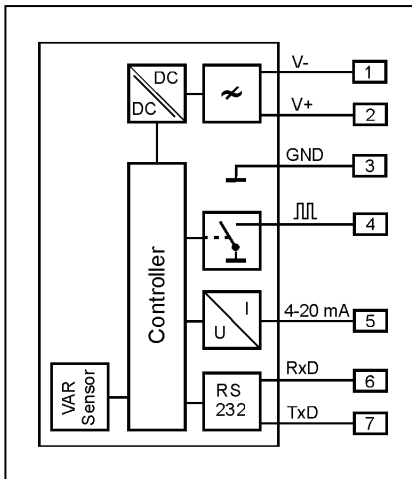

Vortex VAR TwinPipe for ventilator control

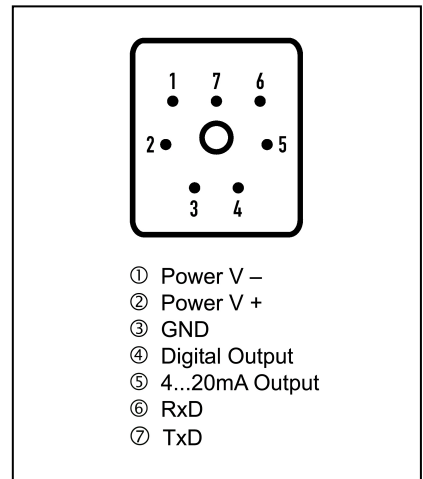

Terminal pin assignment GO 070

Höntzsch GmbH

Gottlieb-Daimler-Straße 37
D-71334 Waiblingen (Hegnach)
Tel: +49 7151 / 17 16-0
Fax: +49 7151 / 5 84 02
E-Mail info@hoentzsch.com
Internet www.hoentzsch.com

Subject to alteration