

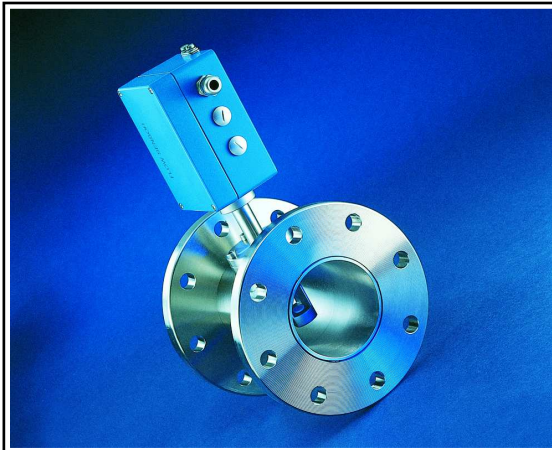

Vortex Flow Sensors VA Di
also suitable for applications in condensation and particle laden gases

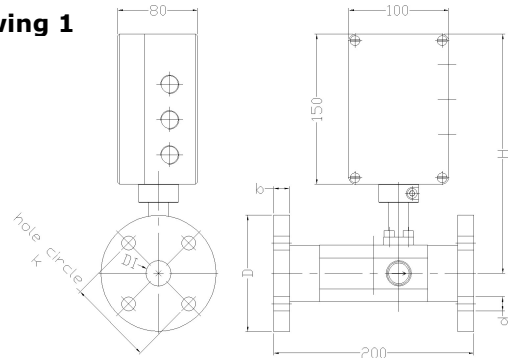

Drawing 1



Measurable variable

- actual flow rate
- standard velocity
- standard flow rate (in combination with pressure and temperature sensors)

Design

- measuring tube

Functional principle

- vortex meter for measuring flow rate and volume
- ultrasonic measurement of the vortex shedding

Advantages

- low starting value
- high measuring dynamics (up to 1 : 100)
- no moving parts
- maximum fatigue strength
- corrosion resistant
- operates to a large extent irrespective of gas composition
- low pressure drop
- easy adjustment to process parameter

Medium

- primarily single-phase gas mixtures with air, nitrogen, oxygen, methane, natural gas, flare gas, ammonia, argon, carbon monoxide, steam ... as dominant component, combustion exhaust gas, bio gas, sewage gas.
- Other gases on request.

Range and examples of application

- flow measurement, for example, of air, exhaust gas, process gas, bio and sewage gas, engine intake air, exhaust emissions, gases laden with particles, dust and fibres, superheated steam

Particles, condensation, humidity in the gas

- charges in the gas caused by particles such as dust and fibres do not affect the measurement, as long as abrasion and agglomeration do not occur on the sensor
- relative gas humidity of less than 100 % does not affect the measurement uncertainty

- depending on the density, condensation on the sensor may affect measurements. The vortex signal processing module VSM can help reduce measurement uncertainty if condensation is moderate; requirement: external evaluation unit instead of integrated transducer UVA



Model designation / order code (example)

VA Di 25	G	E	40 m/s	p10	ZG1
(1)	(2)	(3)	(4)	(5)	(6)

Basic types

Type	<u>without integrated transducer UVA</u> (output v/VA or v/VA-Ex)	<u>with integrated transducer UVA</u> (output 4-20 mA or 0-10 V)
	art. no.	art. no.
VA Di 25 GE 25 m/s / p10 ZG1	b015/010	b015/015
VA Di 25 GT 25 m/s / p10 ZG1	b015/020	b015/025
VA Di 25 GH 25 m/s / p10 ZG1	b015/030	b015/035
VA Di 25 GL 25 m/s / p10 ZG1	b015/040	b015/045
VA Di 40 GE 30 m/s / p10 ZG1	b015/011	b015/016
VA Di 40 GT 30 m/s / p10 ZG1	b015/021	b015/026
VA Di 40 GH 30 m/s / p10 ZG1	b015/031	b015/036
VA Di 40 GL 30 m/s / p10 ZG1	b015/041	b015/046
VA Di 50 GE 30 m/s / p10 ZG1	b015/012	b015/017
VA Di 50 GT 30 m/s / p10 ZG1	b015/022	b015/027
VA Di 50 GH 30 m/s / p10 ZG1	b015/032	b015/037
VA Di 50 GL 30 m/s / p10 ZG1	b015/042	b015/047
VA Di 80 GE 40 m/s / p10 ZG1	b015/013	b015/018
VA Di 80 GT 40 m/s / p10 ZG1	b015/023	b015/028
VA Di 80 GH 40 m/s / p10 ZG1	b015/033	b015/038
VA Di 80 GL 40 m/s / p10 ZG1	b015/043	b015/048
VA Di 100 GE 40 m/s / p10 ZG1	b015/014	b015/019
VA Di 100 GT 40 m/s / p10 ZG1	b015/024	b015/029
VA Di 100 GH 40 m/s / p10 ZG1	b015/034	b015/039
VA Di 100 GL 40 m/s / p10 ZG1	b015/044	b015/049

aA : price on request

(1) Dimensions

tube inside Ø Di [mm]	flange outside Ø D [mm]	flange thickness b [mm]	hole circle Ø k [mm]	hole Ø d [mm]	no. of holes	sensor length [mm]	sensor height H [mm]	sensor weight [kg]
25	115	16	85	14	4	200	245	8
40	150	16	110	18	4	200	250	10
50	165	18	125	18	4	200	250	10
80	200	20	160	18	8	200	270	12
100	220	20	180	18	8	200	286	15

flange dimensions as per DIN 2527 PN16 Form C (other flange dimensions on request)

(2) Medium

Gases

(3) Materials in contact with the medium

design	material
... GE ...	stainless steel 1.4571, ceramics
... GT ...	titanium 3.7161, ceramics
... GH ...	Hastelloy 2.4610 (HC4), ceramics
... GL ...	tantalum, ceramics

(4) Measuring range

Di [mm]	flow rate [m ³ /h]	average flow velocity [m/s]
25	0.7 ... 44	0.4 ... 25
40	1.8 ... 135	0.4 ... 30
50	2.8 ... 212	0.4 ... 30
80	7.2 ... 724	0.4 ... 40
100	11.0 ... 1131	0.4 ... 40

measurement uncertainty	< 1 % of measured value + 0.3 % of terminal value (at +20 °C / 1000 hPa)
repeatability	± (0.2 % of measured value + 0.025 % of terminal value)
input/output sections	in order to achieve as great a measurement accuracy as possible, an input/output section of 20/10 x Di is recommended. The input section can be reduced considerably by using a flow rectifier (see Accessories). Further information on this subject can be found in the Operating Instructions U283_VADi_B_e.

(5) Max. working pressure

up to 10 bar / 1 MPa overpressure

(6) Design

as in Drawing 1

Connection housing AS102

Dimensions	L/W/H: 100/80/150 mm
Material	die-cast aluminium G Al Si12 / DIN 1725
Protection class	IP65, IEC 529 and EN 60 529
Connection	bush for shielded cables with external diameter 5 ... 10 mm, contacting of the overall copper shielding by the metallic screwed cable glands

Electromagnetic compatibility (EMC)

according to EN 61 000-6-2 / IEC77

Mounting attitude

any	to ensure that the sensor remains operative in horizontal pipeline even with moderate condensation, sensors VA Di 25 should be installed with the connection housing pointing upwards, and sensors VA Di 40, VA Di 50, VA Di 80 and VA Di 100 with the connection housing pointing sideways. In vertical pipeline the attitude for all sensors VA Di ... - also in case of moderate condensation - can be chosen freely.
-----	---



Options (A) ... (C)

sealing material	calibration pressure	Ex-protection
(A)	(B)	(C)

Option (A)

material	working temperature range of the medium	permissible ambient temperature		art. no.
		with separate evaluation unit	with integrated transducer UVA	
VITON [®] (standard)	-20 ... +180 °C	-20 ... +80 °C	-20 ... +50 °C	b015/900
silicone	-40 ... +180 °C	-40 ... +80 °C	-25 ... +50 °C	b015/901
KALREZ [®] (Compound 4079)	0 ... +180 °C	0 ... +80 °C	0 ... +50 °C	b015/902
EPDM [®]	-20 ... +160 °C	-20 ... +80 °C	-20 ... +50 °C	b015/903
permissible ambient temperature		0 ... +50 °C with integrated display		

Option (B)

calibration pressure	comment	art. no.
atmospheric pressure	with working pressures greater than 3 bar rel. calibration should be carried out at average working pressure to reduce the risk of measurement uncertainty	b015/910
___ bar rel.	calibration pressure selectable in range 1 ... 10 bar rel.; with working pressures greater than 3 bar rel. calibration at average working pressure is recommended to ensure the smallest possible measurement uncertainty	b015/911

Option (C)

type of protection	comment	art. no.
Ex ia IIC T6 gas-Ex: category 1/2G (zone 0/1) Ex ia IIIC TX dust-Ex: category 1/2D (zone 20/21)	only in conjunction with: • isolation/supply unit LDX2 and 'non-Ex evaluation unit' or • compatible separate evaluation unit with Ex-input (see below) • temperature range of the medium as electrical apparatus for Category 1/2G -20...+60 °C; 2G -40...+180 °C; 1/2D, 2D -40...+180 °C	vaex0
Ex nA IIC T6 Ex tc IIIC TX	category 3G (zone 2) category 3D (zone 22)	vaex2

Output v/VA, v/VA-Ex, 4-20 mA or 0-10 V

output sensor v/VA	Höntzsch evaluation unit ** with v/VA input is necessary for signal interpretation
output sensor v/VA-Ex, (sensor with Option (C) see above)	Höntzsch evaluation unit** with intrinsically safe input v/VA-Ex or an evaluation unit with input v/VA** together with a series connection isolation/supply unit LDX is necessary for signal interpretation
output 4-20mA or 0-10V	with transducer UVA integrated in the connection housing (see Page 5)
** e. g. µP Vortex, VT-VA, VP-VA or VT-VA	



optional transducer UVA, integrated in the sensor connection housing

analog output flow 4-20 mA <u>or</u> 0-10 V (please select)	4 ... 20 mA resistance max. 400 Ohm art. no. b015/050	0 ... 10 V impedance max. 1 kOhm art. no. b015/051
output limit value or quantity pulse	potential-free relay contact (normally open contact), max. 300 mA / 27 VDC	
PC interface	RS232	
self-monitoring	output signals are electrically isolated from the power supply parameter settings, sensor interface; in case of error: analog output less than 3.6 mA or <-0.2 V	
connection	'push in' PCB terminals; no tools necessary for strand connection; disconnect strands by applying pressure with a pen or screwdriver; for strands with cross-section 0.14 ... 1.5 mm ²	
power supply	24 V DC (20 ... 27 V DC)	
power consumption	less than 5 W	
setting parameter	analog output, time constant, profile factor, tube inside diameter, limit value or quantity pulse (quality rating adjustable), switch from actual/standard flow with setting parameters 'working pressure' and 'working temperature'	
setting parameter with PC software UCOM and PC connection cable (see Accessories) alterable		

compatible separate evaluation units

(necessary in conjunction with VA Di sensors without integrated transducer UVA)

for non-Ex applications	UVA, µP-Vortex, VT-VA, VP-VA, VTP-VA
for Ex-applications	1) isolation/supply unit LDX2 in LDG16 housing in combination with evaluation units UVA, µP-Vortex, VT-VA, VP-VA, VTP-VA in LDG housing (additional requirement: Ex-input t, p) 2) µP-Vortex, VT-VA, VP-VA, VTP-VA with Ex-input in other housing versions

Accessories (optional)

	description	art. no.
LCD in housing cover*°	Line 1: 'instantaneous value': flow rate or flow velocity Line 2: 'quantity counter' or 'error code'; 2 x 16 digit, character height 5.5 mm, working temperature range 0 ... +50 °C	a010/016
Calibration certificate		klbneu
PC software UCOM*°	for configuring transducers UFA and UVA via RS232 interface, PC connection cable RJ22 / sub-D 9-pin additional requirement	a010/052
PC connection cable RJ22 / sub-D 9-pin*°	for configuring transducers UFA and UVA in LDG16 or AS102 housing via RS232 interface together with UCOM software; transducer connection: RJ22 PC connection: sub-D 9-pin	a010/051
Interface converter*° USB / RS232	for connecting PC to USB port and Höntzsch programming adapter to RS232 interface; PC connection: USB plug type A prog. adapter connection: sub-D 9-pin	a010/100

*° only in conjunction with integrated transducer UVA (see above)



Accessories (cont.)

Process flange TP

for one temperature sensor (T) and one pressure sensor (P)

identification	art. no.	inside diameter Di [mm]
TP Di/DN 25 PN16	b015/100	25
TP Di/DN 40 PN16	b015/101	40
TP Di/DN 50 PN16	b015/102	50
TP Di/DN 80 PN16	b015/103	80
TP Di/DN100 PN16	b015/104	100
Material	stainless steel 1.4571	
Connecting thread	2 x G 1/4 "	
Installation point	down stream, behind the VA Di sensor	

Flow rectifier

for reducing the input section - including flow rectifier - to 11 x Di

Identification	art. no.	Inside diameter Di [mm]
GL Di/DN 25 PN16	b015/150	25
GL Di/DN 40 PN16	b015/151	40
GL Di/DN 50 PN16	b015/152	50
GL Di/DN 80 PN16	b015/153	80
GL Di/DN 100 PN16	b015/154	100
Material	stainless steel 1.4571	
Installation point	5 ... 8 x Di in front of the VA Di sensor (see Operating Instructions U283_VADi_B_d)	

® Trademark Dupont

Höntzsch GmbH

Gottlieb-Daimler-Straße 37
D-71334 Waiblingen (Hegnach)
Tel: +49 7151 / 17 16-0
Fax: +49 7151 / 5 84 02
E-Mail info@hoentzsch.com
Internet www.hoentzsch.com

Subject to alteration