

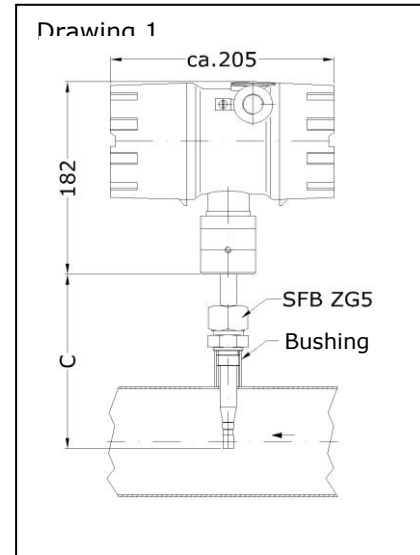

Thermal flow sensor TA10/15 ... ZG1 with integrated, configurable transducer UTA in a flameproof enclosure for applications in explosive atmospheres



Sensor TA10/15 ... ZG1



Connection on-site bushing with inside thread

Measured variables

- standard velocity N_v , standard flow rate N_V/t , mass flow
- standard basis adjustable, default: temperature $t_n = +21\text{ °C}$, pressure $p_n = 1014\text{ hPa}$

Functional principle

- flow measurement according to the heat transfer method
- temperature-compensated measuring

Design

- probe with integrated transducer and flameproof enclosure
- thin film sensor element

Media

- pure gases, gas mixtures: air, nitrogen, methane, natural gas, hydrogen, argon, carbon dioxide, helium, sulphur hexafluoride, landfill gas, ...
- calibration can be carried out with a multitude of gases or gas mixtures to achieve the best measurement uncertainty

Advantages

- applications in explosive atmospheres: Category 1/2 G (Zone 0/1) and Category 1/2 D (Zone 20/21)
- high turndown (up to 1 : 1000)
- low measurement uncertainty, even at lowest flow velocities
- measuring range from 0.2 m/s
- mass flow of air/gases without additional pressure and temperature detection

- no moving parts
- stainless steel sensor housing
- wider temperature and pressure resistance ranges

- low installation costs
- marginal pressure loss
- high durability
- sterilisable (material-resistance of sensor allowing)
- easy adjustment of parameters with HART® interface

Examples of application

- measuring
 - in explosive atmospheres
 - air velocity
 - compressed air and gas consumption as well as leakage flow
 - laminar flow in safety cabinets or machines
 - in exhaust air and burner supply air
 - in air-conditioning applications
 - in air in low vacuum range with pressures higher than 200 hPa abs

Particles and humidity

- dust or fibre particles in the gas do not affect the measurement, as long as these are not abrasive or accumulate on the sensor
- deviations in values as a result of variable air humidity under normal atmospheric conditions are covered by the measurement uncertainty specifications



Model designation / order code (example)

TA10/15	-165	G	E	140	p16	ZG1	Ex-d
(1)	(2)	(3)	(4)	(5)	(6)	(7)	(8)

Basic types

Type	Article No.
TA10/15- 165 GE 140 / p16 / ZG1 / Ex-d	B013/001
TA10/15- 265 GE 140 / p16 / ZG1 / Ex-d	B013/002
TA10/15- 365 GE 140 / p16 / ZG1 / Ex-d	B013/003
TA10/15- 665 GE 140 / p16 / ZG1 / Ex-d	B013/004
TA10/15- 965 GE 140 / p16 / ZG1 / Ex-d	B013/005
TA10/15- 1465 GE 140 / p16 / ZG1 / Ex-d	B013/006

(1) Sensor type / probe diameter

Thermal flow sensor
10/15 mm

(2) Sensor length – measurement C (see Drawing 1, Page 1)

Standard length (see Basic types)	165, 265, 365, 665, 965, 1465 mm
Determining probe length on the basis:	desired insertion depth in measurement cross-section, length of bushing, ball valve and probe guide piece (see Accessories). To avoid vibration additional support may be needed with higher flow velocities and greater insertion depths. Warning Due to the weight of the connection housing, the probe should not protrude more than 150 mm out of the probe guide piece without additional support!

(3) Media

air, pure gases, gas mixtures with constant mix ratio

(4) Materials in contact with the medium

stainless steel 1.4571, 1.4305, glass, epoxy resin

Measuring ranges air/nitrogen

	Article No.
0.2 ... 60 m/s	V_TA10_3B_60
0.2 ... 120 m/s	V_TA10_3B_120
0.2 ... 150 m/s	V_TA10_3B_150
0.2 ... 180 m/s	V_TA10_3B_180
0.2 ... 200 m/s	V_TA10_3B_200

Measurement uncertainty / time constant

measurement uncertainty for flow velocities N_v with 1014 hPa and +21 °C
 less than/equal to 40 m/s : 2 % of measured value + 0.02 m/s
 greater than 40 m/s : 2.5 % of measured value
 time constant : in seconds



Storing a characteristic for application in other gases

based on	Article No.
calibration in air and conversion of the air characteristic for another gas, up to '60 m/s'	TA_TRANSFO (on request)
real gas calibration for achieving best measurement uncertainties	(on request)

Examples of measurable flow rates

measuring tube inside diameter Di [mm]	profile factor PF* [-]	smallest measurable value [Nm ³ /h]	terminal value [Nm ³ /h] with sensor measuring range				
			'60 m/s'	'120 m/s'	'150 m/s'	'180 m/s'	'200 m/s'
40	0.810	0.73	220	440	550	660	730
50	0.840	1.2	356	713	890	1070	1180
60	0.840	1.7	513	1030	1280	1540	1710
80	0.840	3.0	912	1820	2280	2740	3040
100	0.840	4.8	1425	2850	3560	4280	4750
120	0.840	6.8	2050	4100	5130	6160	6840
150	0.840	11	3210	6410	8020	9620	10600
200	0.840	19	5700	11400	14250	17100	19000
300	0.840	43	12820	25650	32060	38480	42750
400	0.840	76	22800	45600	57000	68400	76000
500	0.840	120	35600	71200	89100	106900	118800
1000	0.840	480	142500	285000	356300	427600	475000

Standard flow rate measuring range specifications with centric positioning of the sensor, non-rotational inlet flow and amply dimensioned input/output sections (see Information for Use).

* The profile factor PF describes the ratio of average flow velocity in the measurement cross section and the flow velocity measured from the sensor. The afore-mentioned operating conditions apply.

(5) Permissible temperature

medium	-10 ... +140 °C
ambient	-20 ... +50 °C

Permissible ambient and media temperature ranges subject to the chosen temperature class. Ambient temperature (electronics) T_U , media temperature T_M

Category 1/2G equipment		
Temperature class	T_M	T_U
T4	- 10 °C ... +60 °C	- 20 °C ... +50 °C
T3	- 10 °C ... +60 °C	- 20 °C ... +50 °C
Category 2G equipment		
Temperature class	T_M	T_U
T4	- 10 °C ... +130 °C	- 20 °C ... +50 °C
T3	- 10 °C ... +140 °C	- 20 °C ... +50 °C
T2	- 10 °C ... +140 °C	- 20 °C ... +50 °C
T1	- 10 °C ... +140 °C	- 20 °C ... +50 °C
Category 1/2D or 2D equipment		
maximum surface temperature		T_U
T 135 °C		- 20 °C ... +50 °C



(6) Working pressure

max. 16 bar / 1.6 MPa overpressure
higher than 16 bar / 1.6 MPa on request

(7) Design

as in Drawing 1 (Page 1)

(8) ATEX protection

for gas : Ⓜ II 1/2 G Ex ia/d e [ia] IIC T4 Ga/Gb
for dust : Ⓜ II 1/2 D Ex ia/tb IIIC T135°C Da/Db
sensor : Category 1 (Zone 0 or 20)
transducer housing : Category 2 (Zone 1 or 21)

Installation position

any positioning under atmospheric pressure, with overpressure inflow must not come from above

Ex-d transducer housing

Dimensions	outside diameter/length/height: approx. 110/205/182 mm
Material	aluminium cast alloy max. 0.5 % Mg, coated
Protection	IP68, IEC 529 and EN 60 529
Connection	glands for shielded cables with outside diameter 5 ... 9 mm, contacting of overall screen on the ground terminal in the housing
Alignment	rotatable by approx. 350 ° and lockable
Setup	dual chamber system consisting of: 1) electronics in Ex-d protection (flameproof enclosure) 2) connections in Ex-e protection (increased safety) with terminal block and cable glands

Electromagnetic Compatibility (EMC)

according to EN 61 000-6-2 / IEC77

Transducer UTA integrated in the connection housing

Analog output flow	4 ... 20 mA resistance max. 500 Ohm
Output limit value or quantity pulse	potential-free relay contact (normally-open) max. 300 mA / 27 VDC
Communication port	HART® via modem adapter for PC connection and UCOM software (see Accessories) output signals are electrically isolated from the power supply
Self-monitoring	parameter settings, sensor interface; in the case of error: analog output < 3.6 mA
Power supply	24 V DC (20 ... 27 V DC)
Power consumption	less than 5 W
Setting parameters	analog output, time constant, profile factor, tube inside diameter, limit value or quantity pulse (rating adjustable), 'working pressure' to zero correction (only relevant for $N_v < 1$ m/s), standard basis, standard density



Accessories (optional)

	Description	Article No.
LCD display	1 st row: 'instantaneous value': flow rate or flow velocity 2 nd row: 'counter' or 'error code' 2 x 16-digit, character height 5.5 mm, working temperature range -20 ... +50 °C display rotatable in 90 °-stages on removing the Ex-d housing window cover	A010/520
Calibration certificate v/VA		KLB
HART® modem adapter	for changing setting parameters, for PC-USB connection	A010/101
PC software UCOM	for configuring the UTA via RS232	A010/052



Ex-d transducer housing with optional LCD display

Drawing 5
SFB 15 E-43 / G 3/4" ZG5

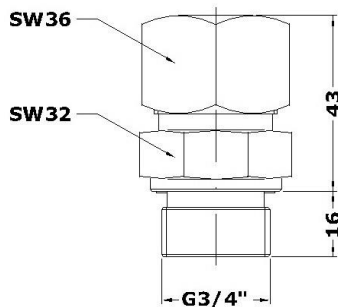

Drawing 2
SFK 15 E-42 / G 3/4" ZG2

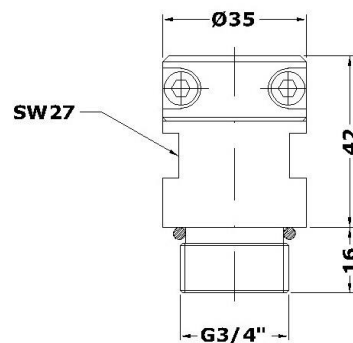



Accessories (cont'd)		
Probe guide piece	Description	Article No.
SFB 15 E-43 / G 3/4" ZG5 Drawing 5*	for any repeated positioning with lower pressures above atmospheric (up to 3 bar)/sub-atmospheric pressures, screwed socket or ball valve connection with inside thread G 3/4", working temperature range -20 ... +240 °C installation length approx. 43 mm, materials: stainless steel, VITON®, PTFE clamping bush	B004/515
SFK 15 E-42 / G 3/4" ZG2 Drawing 2	for any repeated positioning with pressures up to 1.6 MPa/16 bar, screwed socket or ball valve connection with inside thread G 3/4", working temperature range -20 ... +240 °C installation length approx. 42 mm materials: stainless steel, VITON®, PTFE clamping bush, probe attachment by clamping yoke	B004/220

* Locking torque min. 60 Nm

® Registered trademark:
Dupont: VITON
HART: HART Communication
Foundation

Höntzsch GmbH
Gottlieb-Daimler-Straße 37
D-71334 Waiblingen (Hegnach)
Telefon +49 7151 / 17 16-0
Telefax +49 7151 / 5 84 02
E-Mail info@hoentzsch.com
Internet www.hoentzsch.com

Subject to alteration