

The Hydraulic Pressure Seal **SATRON HPS** is used in pressure measurement applications where the process medium is aggressive and it is necessary to protect the wetted parts of measuring transmitters. Processes' hygienic requirements may also necessitate the use of the pressure seal. In addition, the pressure seal has to be used when the process temperature exceeds the transmitter's specifications.



Technical specifications

Process connections

- DN25, DN50, DN80, DN100 (EN 1092-1, flange type 05, facing type B), (DIN 2501, form D)
- ANSI 2" and 3" (ANSI B16-5)
- JIS 50, 80, 100 (JIS B 2220)
- Sandvik Clamp connector DN65
- TRI-Clamp 1½", 2" and 2,5" (38/51/63,5 mm, ISO2852)
- SMS38 and SMS51
- DIN11851 DN25... DN50
Other options available on separate order.

Process pressures

- PN10/16, PN40, PN64 and PN100
- 150 and 300 lbs
- 10K and 50K
- Sandvik Clamp: PN64
- TRI-Clamp: PN40
- SMS and DIN11851 PN25 PN40

Measurement ranges

Above 25 mbar span, depending on the measuring diaphragm's size and the process pressure.

Materials

HPS body: EN 1.4401 (AISI 316)
Process coupling: EN 1.4404 (AISI 316L)

Capillary tube

- Capillary: EN 1.4401 (AISI 316)
 - Casing: EN 1.4401 (AISI 316)
- Length selectable between 2 and 20 m.
Recommendation: As short as possible.
The capillary's minimum permissible bending radius is 50 mm.
We recommend capillaries of equal length for differential pressure measurements in varying temperature conditions.

Diaphragm materials

EN 1.4435 (AISI 316L), CoNi-alloy, Duplex (EN 1.4462), Hastelloy C22 (EN 2.4602) / C-276 (EN 2.4819), Inconel 600 (EN 2.4816), Monel 400 (EN 2.4360), Nickel (EN 2.4066), Tantalum, Titan Ti-II (3.7035) and Zirkonium

Fill fluids

- Silicone oil DC200
- for process and food industry applications
NeobeeM20
 - for food industry applications
Inert oil (e.g. Fomblin Y04 or Halocarbon)
 - for oxygen and chlorine applications

Silicone oil DC705

- for high-temperature and vacuum measurement applications

Gaskets (Sanitary Seal)

- EPDM, FPM (Viton®) and PTFE

Fill fluid properties

Fill fluid	Temperature range/°C	Density g/cm ³	Thermal expansion coefficient/ 1/°C	Viscosity (25°C) cSt(mm ² /s)
DC200 Silicone oil	-40...200	0.934	0.00108	9.5
DC705 Silicone oil	20...380	1.090	0.00080	175
Inert oil	-45...175	1.850	0.000864	6.5
NeobeeM20	-17...200	0.917	0.001008	9.8

Fill fluid steam pressure curves (specified by manufacturers)

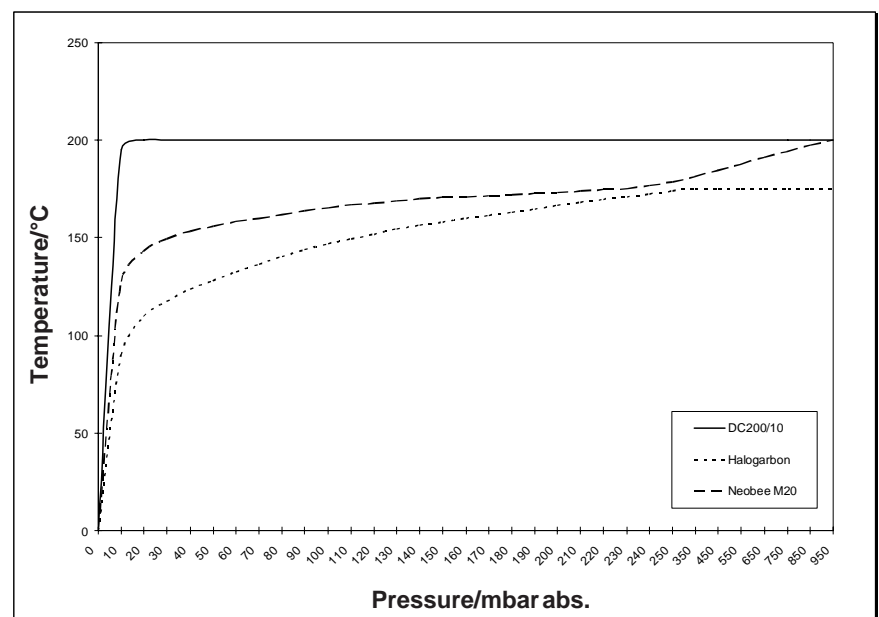

HPS types: construction



SATRONHPS D
- Mounted between
two flanges

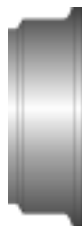

SATRONHPS TRI-C
- Mounted on Tri-Clamp
(ISO2852)
- Sanitary seals



SATRONHPS F
- Flange-mounted
pressure seal



SATRONHPS SMS
- Sanitary seals
- Female Rd-thread

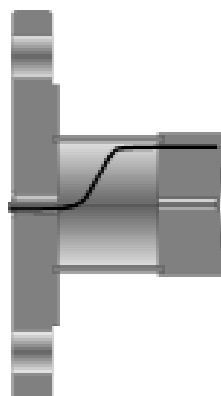

SATRONHPS E
- Flange-mounted
with extension

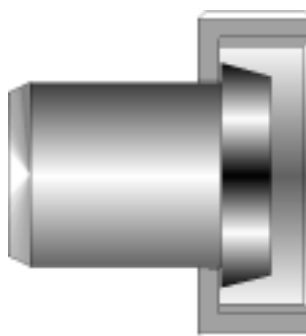

SATRONHPS DIN11851
- Sanitary seals
- Female Rd-thread

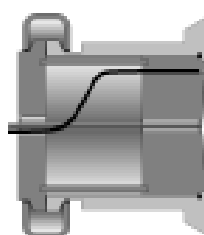

SATRONHPS S
- Mounted on
Sandvik Clamp
- Sanitary seals

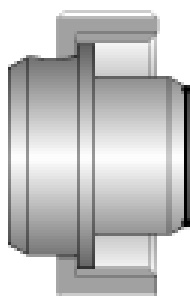

SATRONHPS SMS-SI
- Sanitary seals
- Female Rd-thread

Mounting dimensions

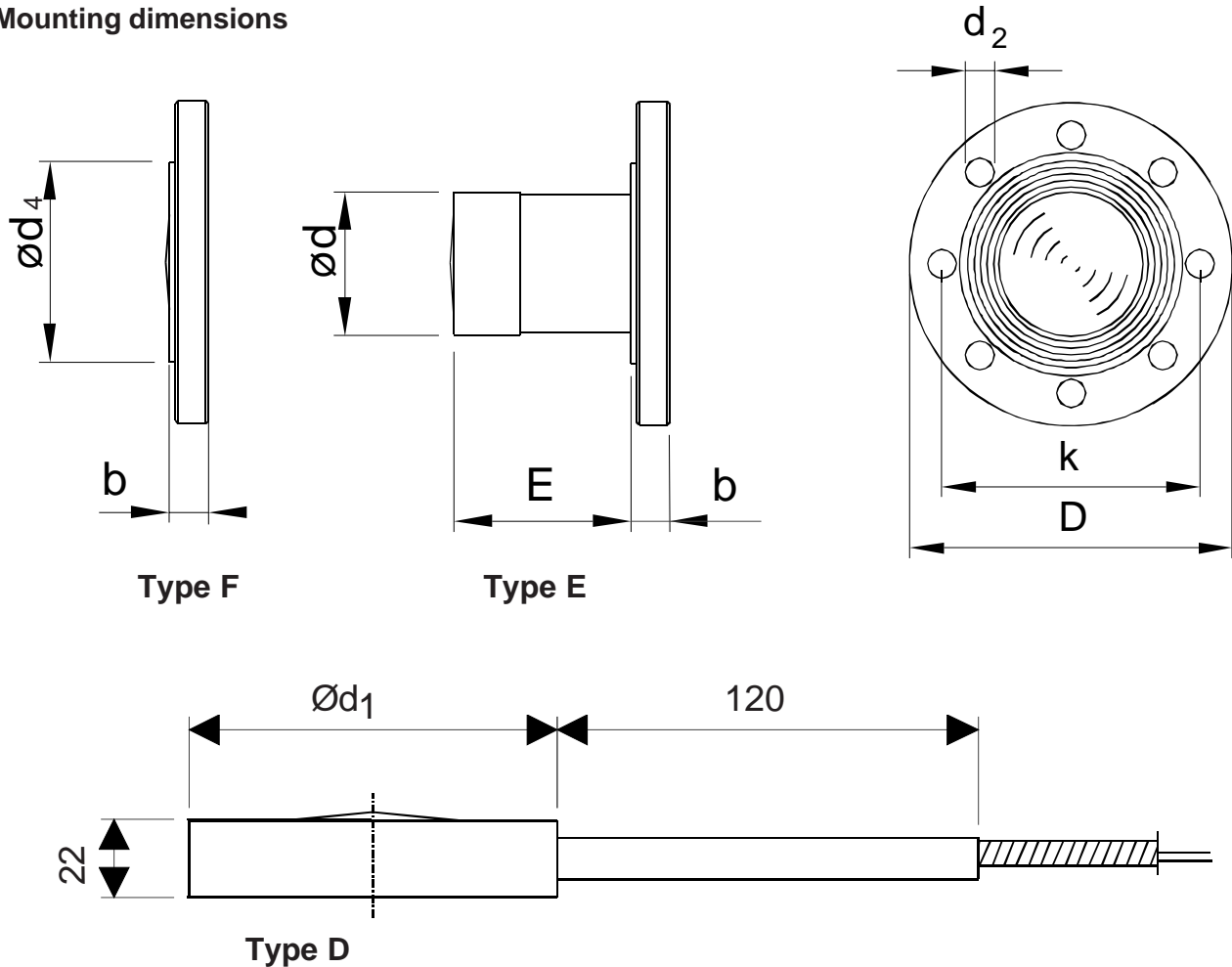

FLANGE SIZE	FLANGE CODE	FLANGE DIMENSIONS				HOLES			EXTENS.
		b	D	$\text{Ø}d_4$	$\text{Ø}d_1$	Kpl	d_2	k	$\text{Ø}d -0.2$
ISO DN25 PN10/16	D1A	16	115	68	70	4	14	85	-
ISO DN25 PN40	D1B	18	115	68	70	4	14	85	-
ISO DN25 PN64	D1C	24	140	68	70	4	18	100	-
ISO DN25 PN100	D1D	24	140	68	70	4	18	100	-
ISO DN50 PN10/16	D2A	18	165	102	105	4	18	125	51
ISO DN50 PN40	D2B	20	165	102	105	4	18	125	51
ISO DN50 PN64	D2C	26	180	102	105	4	22	135	51
ISO DN50 PN100	D2D	28	195	102	105	4	26	145	51
ISO DN80 PN10/16	D3A	20	200	138	140	8	18	160	73
ISO DN80 PN40	D3B	24	200	138	140	8	18	160	73
ISO DN80 PN64	D3C	28	215	138	140	8	22	170	73
ISO DN80 PN100	D3D	32	230	138	140	8	26	180	73
ISO DN100 PN10/16	D4A	20	220	158	166	8	18	180	73
ISO DN100 PN40	D4B	24	235	162	166	8	22	190	73
ANSI 2" 150 lbs	A2A	23	152	92	99	4	20	120.6	51
ANSI 2" 300 lbs	A2B	25	165	92	105	8	20	127	51
ANSI 3" 150 lbs	A3A	26	191	127	130	4	20	152.4	73
ANSI 3" 300 lbs	A3B	31	210	127	143	8	23	168.3	73
ANSI 4" 150 lbs	A4A	26	229	157	168	8	20	190.5	73
ANSI 4" 300 lbs	A4B	34	254	157	175	8	23	200	73
JIS 10K-50	J2A	16	155	96	96	4	19	120	51
JIS 40K-50	J2B	26	165	105	105	8	19	130	51
JIS 10K-80	J3A	18	185	126	126	8	19	150	73
JIS 40K-80	J3B	32	210	140	140	8	23	170	73
JIS 10K-100	J4A	18	210	151	151	8	19	175	73
JIS 40K-100	J4B	36	250	165	165	8	25	205	73

CODE	E
2	51
4	102
6	152

Selection table : Sanitary Seals

HPS		<input type="checkbox"/>	<input type="checkbox"/>	<input type="checkbox"/>	<input type="checkbox"/>	<input type="checkbox"/>	<input type="checkbox"/>	<input type="checkbox"/>	<input type="checkbox"/>	<input type="checkbox"/>	<input type="checkbox"/>	<input type="checkbox"/>	<input type="checkbox"/>	<input type="checkbox"/>	<input type="checkbox"/>	<input type="checkbox"/>	<input type="checkbox"/>	<input type="checkbox"/>
Process connection type and size																		
HA	SMS38																	
HB	SMS51																	
KA	DIN11851 DN25																	
KB	DIN11851 DN32																	
KC	DIN11851 DN42																	
KD	DIN11851 DN50																	
S2	Sandvik-Clamp DN65, extension length 54.5 mm																	
S4	Sandvik-Clamp DN65, extension length 105 mm																	
S6	Sandvik-Clamp DN65, extension length 156 mm																	
TA	Tri-Clamp 38 (1½")																	
TB	Tri-Clamp 51 (2")																	
TC	Tri-Clamp 63.5 (2½")																	
WA	SMS-SI 38, extension length 24 mm																	
WB	SMS-SI 51, extension length 27 mm																	
Material of body, wetted material only in type SMS-SI																		
2	EN 1.4404 (AISI316L)											8	Duplex (EN 1.4462) (*)					
3	Hastelloy C-276 (EN 2.4819) (*)																	
Diaphragm material																		
2	EN 1.4435 (AISI316L)											7	CoNi-alloy					
3	Hastelloy C-276 (EN 2.4819)											8	Duplex (EN 1.4462)					
4	Inconel 600 (EN 2.4816)											H	Hastelloy C22 (EN 2.4602)					
5	Tantalum											M	Monel 400 (EN 2.4360)					
Diaphragm thickness																		
E	0.05 mm (**)											F	0.10 mm (***)					
Diaphragm coating																		
0	No coating											P	PTFE sintered					
9	Gold / Rhodium											Y	Diamond					
Fill fluid																		
S	Silicone oil DC200											G	Inert oil					
A	Neobee M20, oil for food industry											D	Silicone oli DC705					
Process gasket / material of gasket																		
0	No gasket											1	EPDM (ethylene propylene rubber)					
2	FPM (Viton®)											3	PTFE (Not process connection SMS-SI)					
Mounting parts																		
0	No mounting parts											1	For type SMS, coupling and gasket					
2	For type DIN11851, coupling and gasket											3	For type Sandvik, coupling, gasket and clamp					
4	For type Tri-clamp, coupling, gasket and clamp											5	For type SMS-SI, coupling for pipe					
6	For type SMS-SI, coupling for vessel																	
												(*) = Only SMS-SI						
												(**) = Not Inconel or Monel						
												(***) = Not Tantalum						

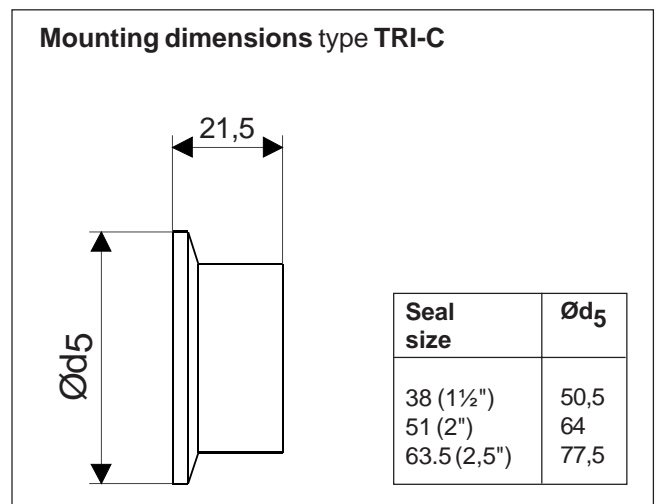
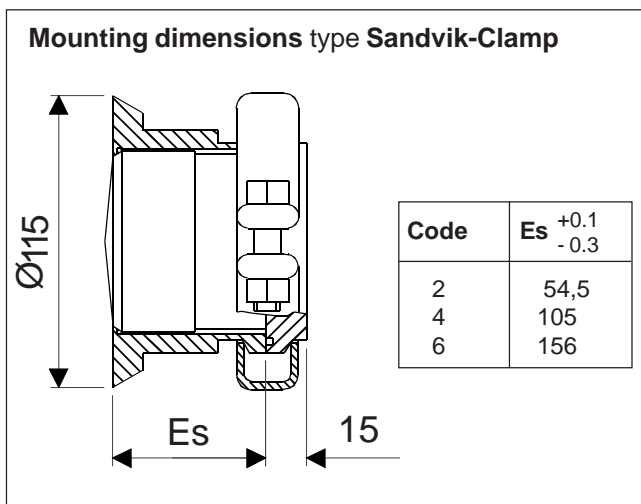

Mounting dimensions type SMS

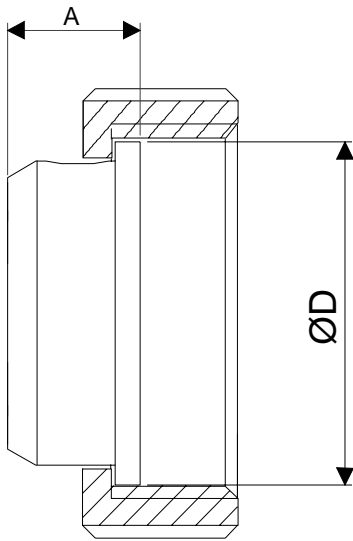

Size	Dimensions		Thread
	ØD	A	
38	54	21	Rd 60 x 1/6
51	64	23	Rd 70 x 1/6

Mounting dimensions type DIN11851

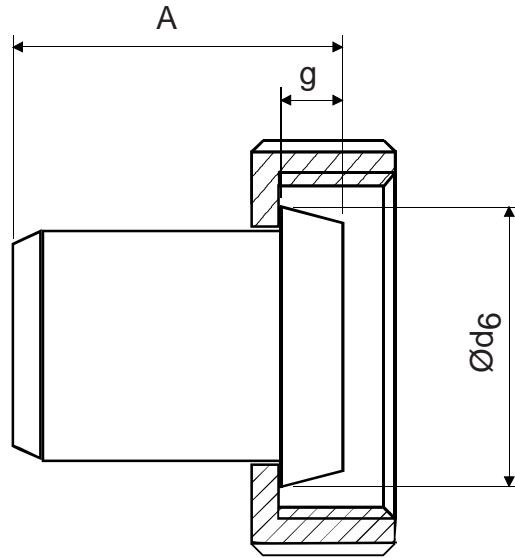

Size	Dimensions			Thread
	Ød ₆	g	A	
DN25 PN25	44	10	49	Rd 52 x 1/6
DN32 PN25	50	10	49	Rd 58 x 1/6
DN40 PN25	56	10	49	Rd 65 x 1/6
DN50 PN25	68,5	11	50	Rd 78 x 1/6

Mounting dimensions type SMS-SI

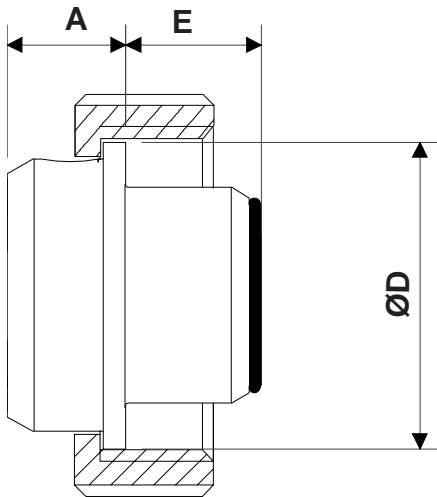

Size	Dimensions			Thread
	ØD	A	E	
SI38	54	21	24	Rd 60 x 1/6
SI51	64	23	27	Rd 70 x 1/6

SMS-SI couplings :

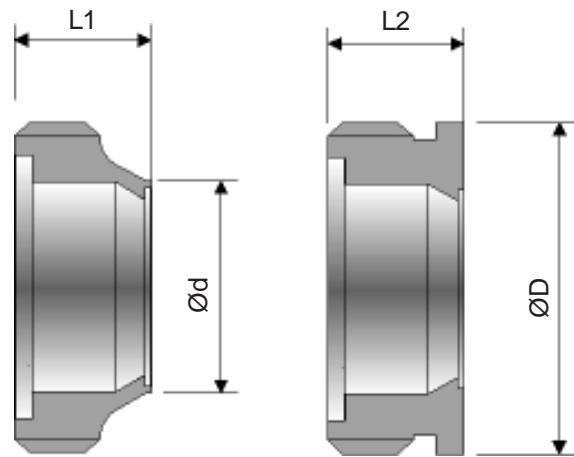

for pipe

for vessel

Size	Dimensions				Thread
	L1	Ød	L2	ØD	
38	27	38,5	24	60	Rd 60 x 1/6
51	30	51	25	70	Rd 70 x 1/6

Hydraulic Pressure Seal Connections

Capillary connection

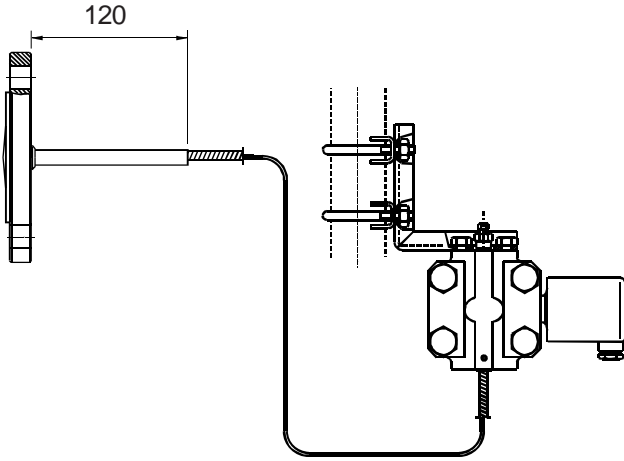

Seal on Low or High pressure side of Differential Pressure Transmitter, code **H** or **K**

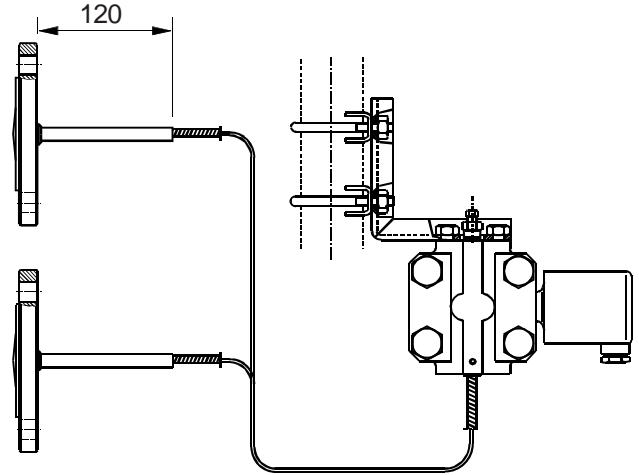

Same seal on both High and Low pressure sides of Differential Pressure Transmitter, code **L**

Selection table



Capillary connection type

- H** Seal on High pressure side of Differential Transmitter
- K** Seal on Low pressure side of Differential Transmitter
- L** Same seal on both High and Low pressure side of Differential Transmitter
- M** Seal on High pressure side of Pressure Transmitter, process connection G $\frac{1}{2}$ A

Capillary length (m)

2...20

Mounting bracket for transmitter

- 0** No mounting bracket
- 1** Angle mounting bracket
- 2** Mounting plate

Documentation

- IE** English
- IF** Finnish

Material certificate

- 0** No material certificate
- MC1** SFS-EN 10204-2.1 (DIN50049-2.1)
- MC2** SFS-EN 10204-2.2 (DIN50049-2.2)
- MC3** SFS-EN 10204-3.1B (DIN50049-3.1B)

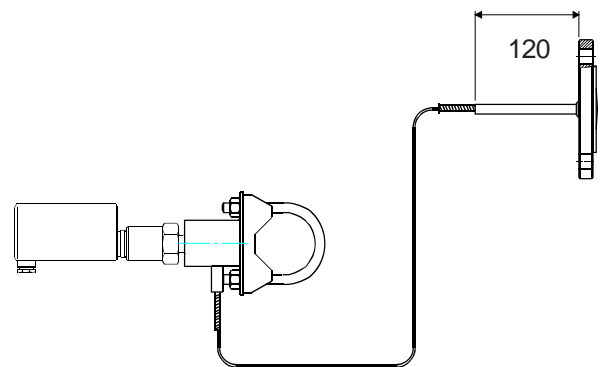

Seal on High pressure side of pressure transmitter, process connection G $\frac{1}{2}$ A, code **M**

Hydraulic Pressure Seal Connections

Direct mounted connection

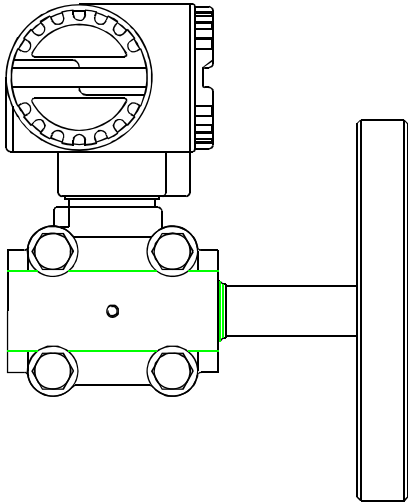

Seal on High pressure side of Differential Pressure Transmitter, angle model, code **P**

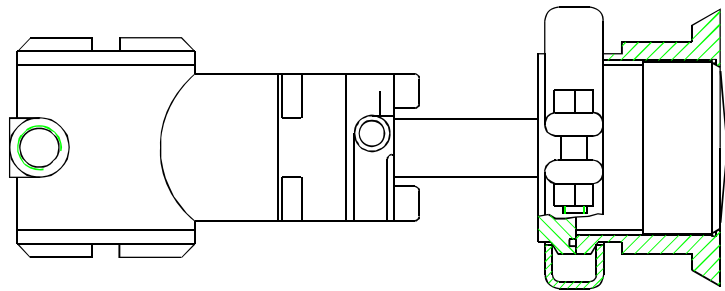

Seal on High pressure side of Differential Pressure Transmitter, straight model, code **R**

Selection table

Direct mounted connection type

- P** Seal on High pressure side of Differential Transmitter, angle model
- R** Seal on High pressure side of Differential Transmitter, straight model
- S** Seal on High pressure side of Pressure Transmitter, process connection G $\frac{1}{2}$ A, straight model

Documentation

- IE** English
- IF** Finnish

Material certificate

- 0** No material certificate
- MC1** SFS-EN 10204-2.1 (DIN50049-2.1)
- MC2** SFS-EN 10204-2.2 (DIN50049-2.2)
- MC3** SFS-EN 10204-3.1B (DIN50049-3.1B)

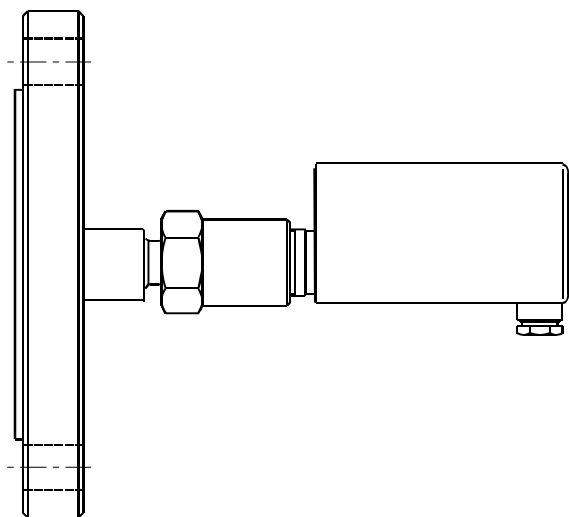

Seal on High pressure side of Pressure Transmitter, process connection G $\frac{1}{2}$ A, straight model, code **S**

HPS types: Installation

Type D Mounted between two flanges

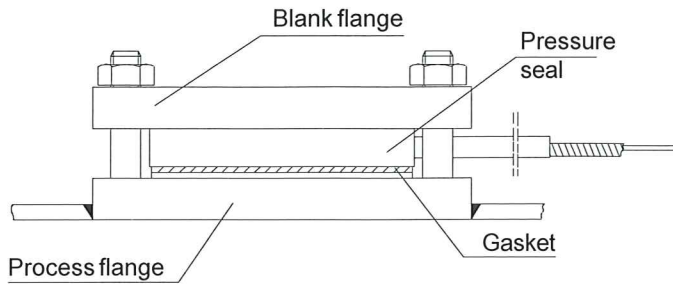

Type TRI-C

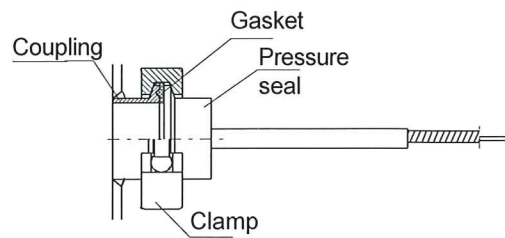

Type F
Flange-mounted pressure seal

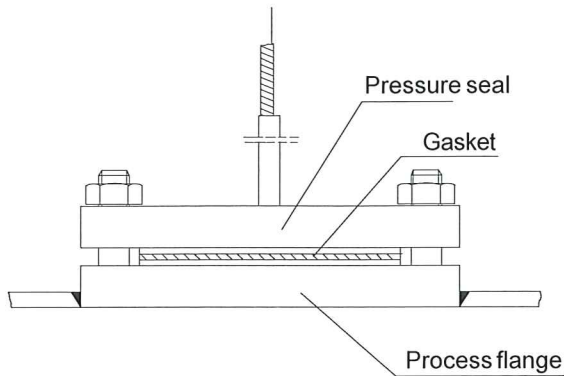

Type E
Flange-mounted with extension

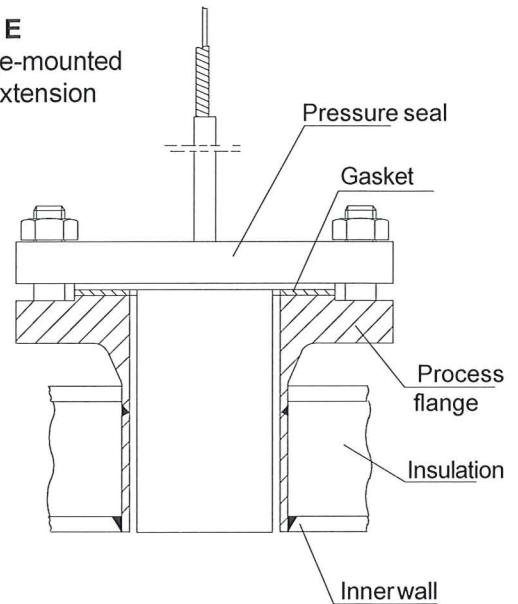

Type S
Mounted on Sandvik Clamp

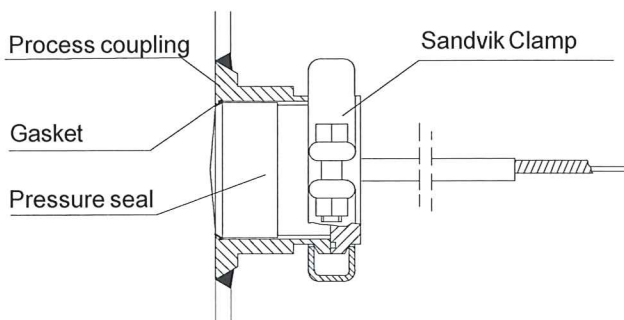

Type S - Coupling installation

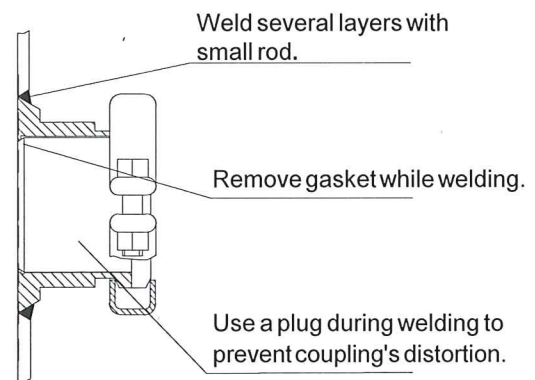

Type S - Mounting parts

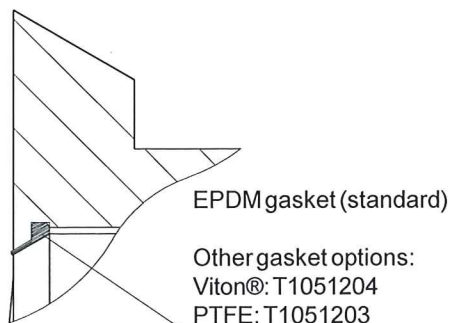

Type S - Plug

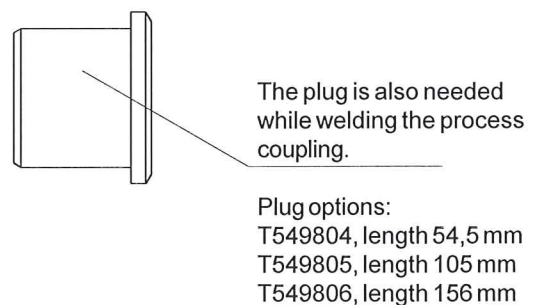

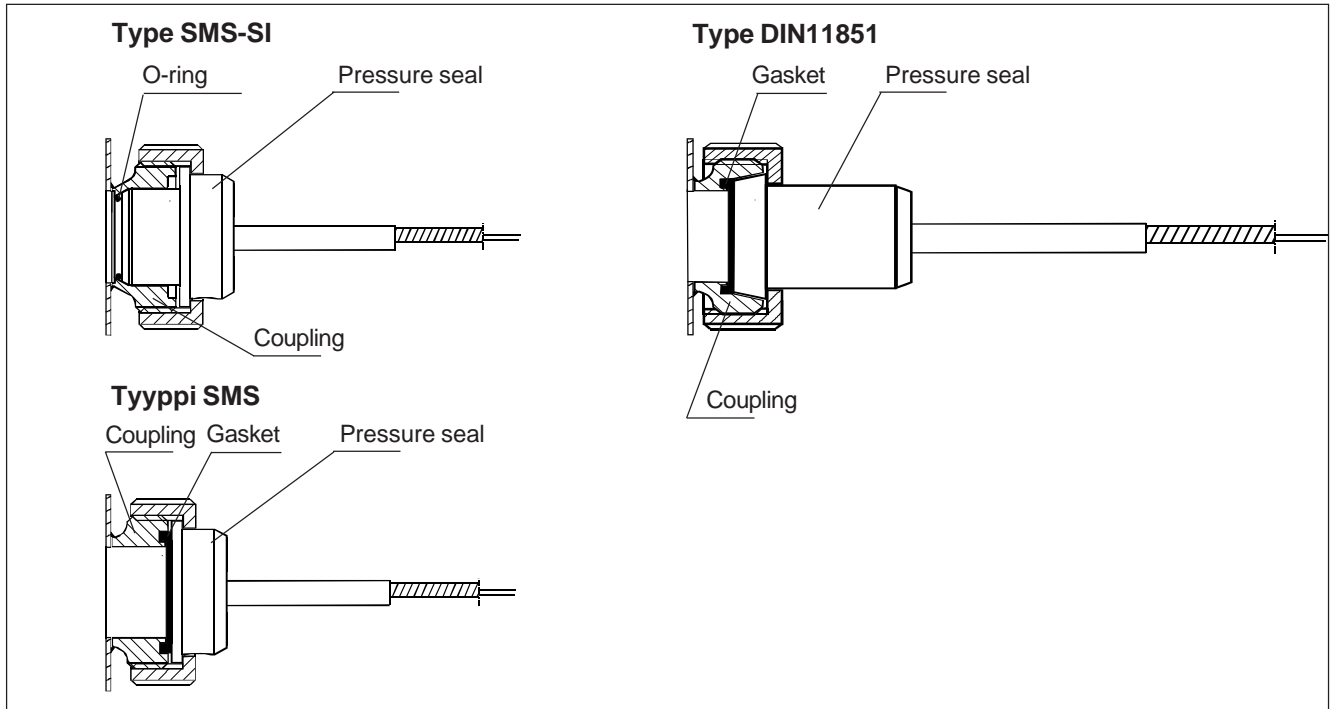

Specification example: **SATRON HPS KA23E0S10-M52IE0**

- Process connection type, sanitary DN25 DIN11851
- Material of body: EN 1.4404 (AISI316L)
- Diaphragm material: Hastelloy C-276 (EN 2.4819)
- Diaphragm thickness: 0.05mm
- No diaphragm coating
- Fill fluid: silicone oil
- Material of process gasket: EPDM
- No mounting parts
- Capillary type connection:
 - Seal on high pressure side of Pressure Transmitter
 - Capillary length 5m
 - Mounting bracket for transmitter, type mounting plate
 - Documentation: English
 - No material certification

Recommended minimum process pressure for vacuum applications

T _{proc.} °C	Minimum pressure for different fill fluids (kPa, abs.)	
	DC200 100 cSt	Inert oil
20	5	8
40	8	10
80	10	28
120	15	53
160	25	90
200	40	-

Hastelloy is the registered trademark of Haynes International.
Teflon is the registered trademark of E.I. du Pont de Nemours & Co.
Viton is the registered trademark of DuPont Dow Elastomers.

We reserve the right for technical modifications without prior notice.