

Installation and Setting-Up Instructions

Spare Parts List

**Contents :**

- 1 TECHNICAL DATA**
- 2 CONSTRUCTION AND OPERATION**
- 3 INSTALLATION**
- 4 SETTING-UP**
- 5 MAINTENANCE**

DOCUMENTS

Technical Specifications : G360

Installation and Setting-Up Instructions : G360AV

We reserve the right for technical modifications without prior notice.

PASVE® is the registered trademark of Satron Instruments Inc.

**Satron Instruments Inc.**

P.O. Box 22, FIN-33901 Tampere

Tel. +358 207 464 800

Telefax +358 207 464 801

www.satron.com, info@satron.com

1. TECHNICAL DATA

PASVE® BA is a ball-type mounting & service valve for SATRON VL and VDtL type pressure and differential pressure transmitters and SATRON HPS hydraulic pressure seals.

PASVE® BA makes it simple to disconnect the transmitter from the process for maintenance and cleaning, without stopping the process or draining the tank.

PASVE® BA is available in a manually operated type or equipped with a pneumatic actuator.

TECHNICAL SPECIFICATIONS

Transmitter connection

M45x2 female, seat accepts SATRON VL and VDtL type pressure and differential pressure transmitters and SATRON HPS hydraulic pressure seals.

Max. operating pressure/temperature

Pressure 40 bar, temperature 250 °C, (see the appended table).

Min. operating temp. -50 °C.

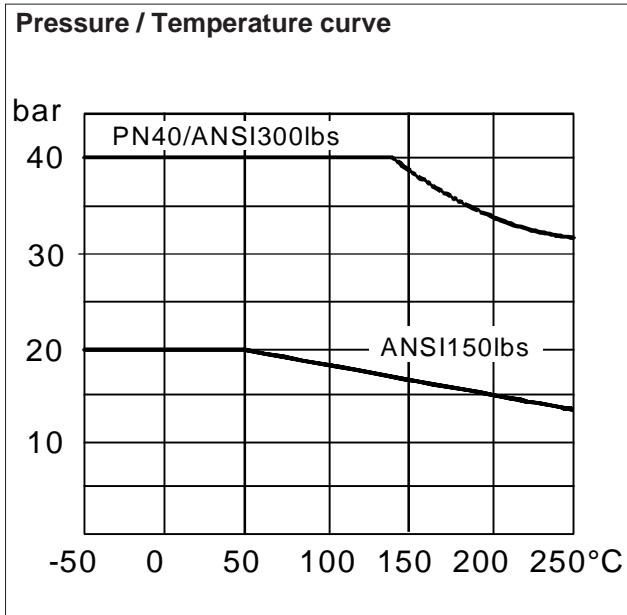

Surface temperature

Ambient temperature °C	Temperature class
70	T6
85	T5
120	T4

Materials

Wetted parts: AISI316L (EN 1.4404), AISI904L (EN 1.4539), Duplex (EN 1.4462), Hastelloy® C276 (EN 2.4819), 254 SMO®, Titanium.

Seals: PTFE or PTFE with carbon and graphite filling or PTFE 50%+AISI316 50% mixture.

Weight

PASVE BA C 4,3 kg, **PASVE BA P** 4,2 kg,

European Directive Information

ATEX directive (94/9/EC)

Satron Instruments Inc. complies with the ATEX directive.

European Pressure Equipment Directive (PED) (97/23/EC)

- Sound Engineering Practice

European Certification :

II 3 GD

EC DECLARATION OF CONFORMITY



Type of Equipment Mechanical Actuators and Valves
Brand Name Pistot, Parve
Type Designation Pistor 75/150, Pistor 75/300, Pistor 75/300 Special, Parve, ParvepH
Manufacturer Satron Instruments Inc., Luompolkka 1, 33000 Tampere, Finland Tel. +358 207 464 800. Fax. +358 207 464 881
We hereby declare that the equipment specified above is in conformity with the provisions of: Machines Directive (98/37/EC) incl. latest amendments: Conformity assessment procedure followed: Module A Conformity is verified by the manufacturer. Conformity is maintained by the use of good engineering practice. Production control follows the ISO9001:2008 regulations and includes required electrical safety routine tests. Pressure Equipment Directive (PED) (97/23/EC) Conformity Assessment procedure followed: Category 1 : Module A Conformity is verified by the manufacturer. Atmosphere Explosive Directive (AEx) (94/9/EC) incl. latest amendments with the application of the harmonized standards: ISO 13481-1:2000+ AC1900 Conformity assessment procedure followed: Category 3 : Module A Conformity is verified by the manufacturer.

Tampere 2009-05-20

Timo Blom, Managing Director

2. CONSTRUCTION AND OPERATION

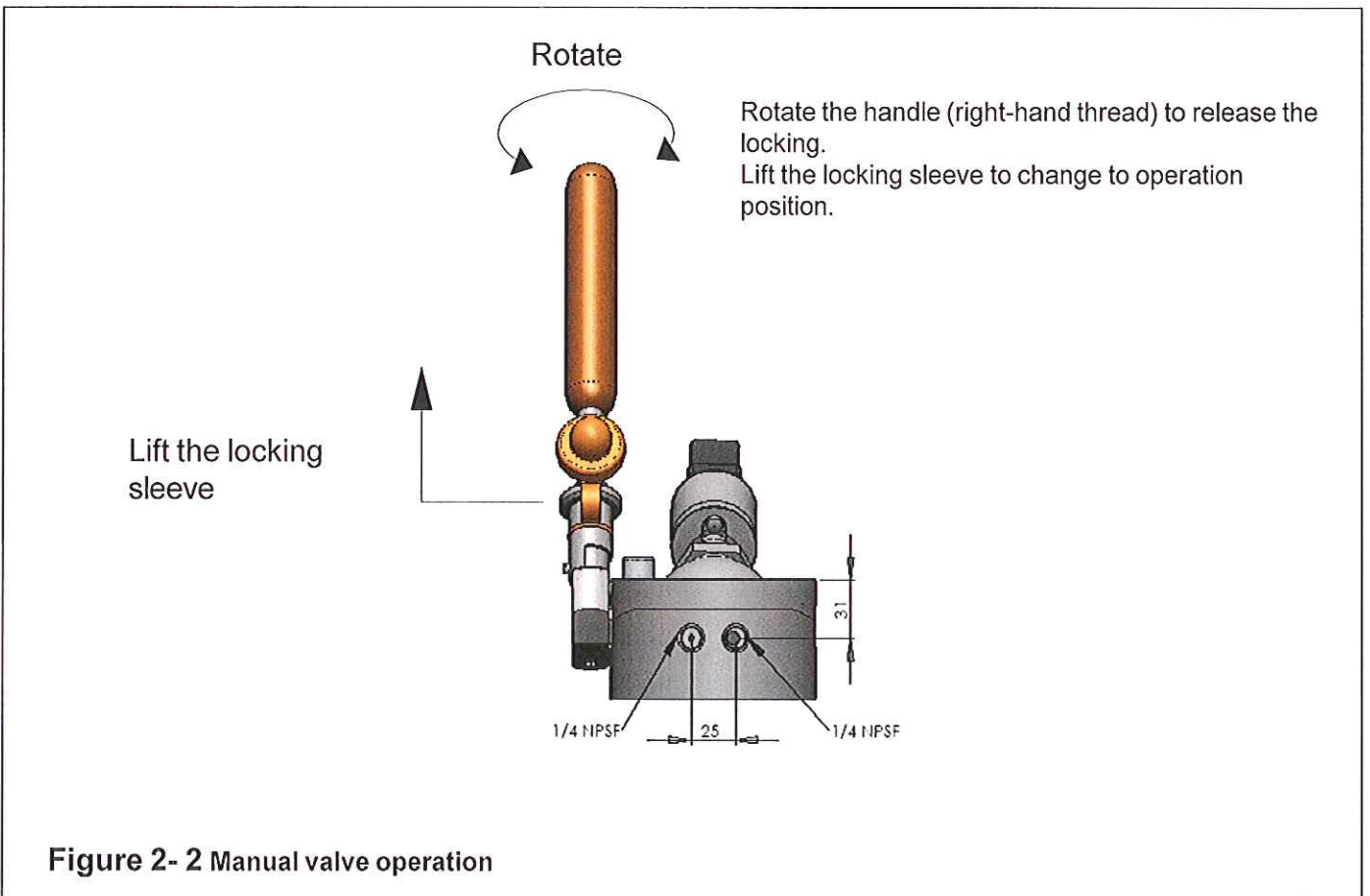
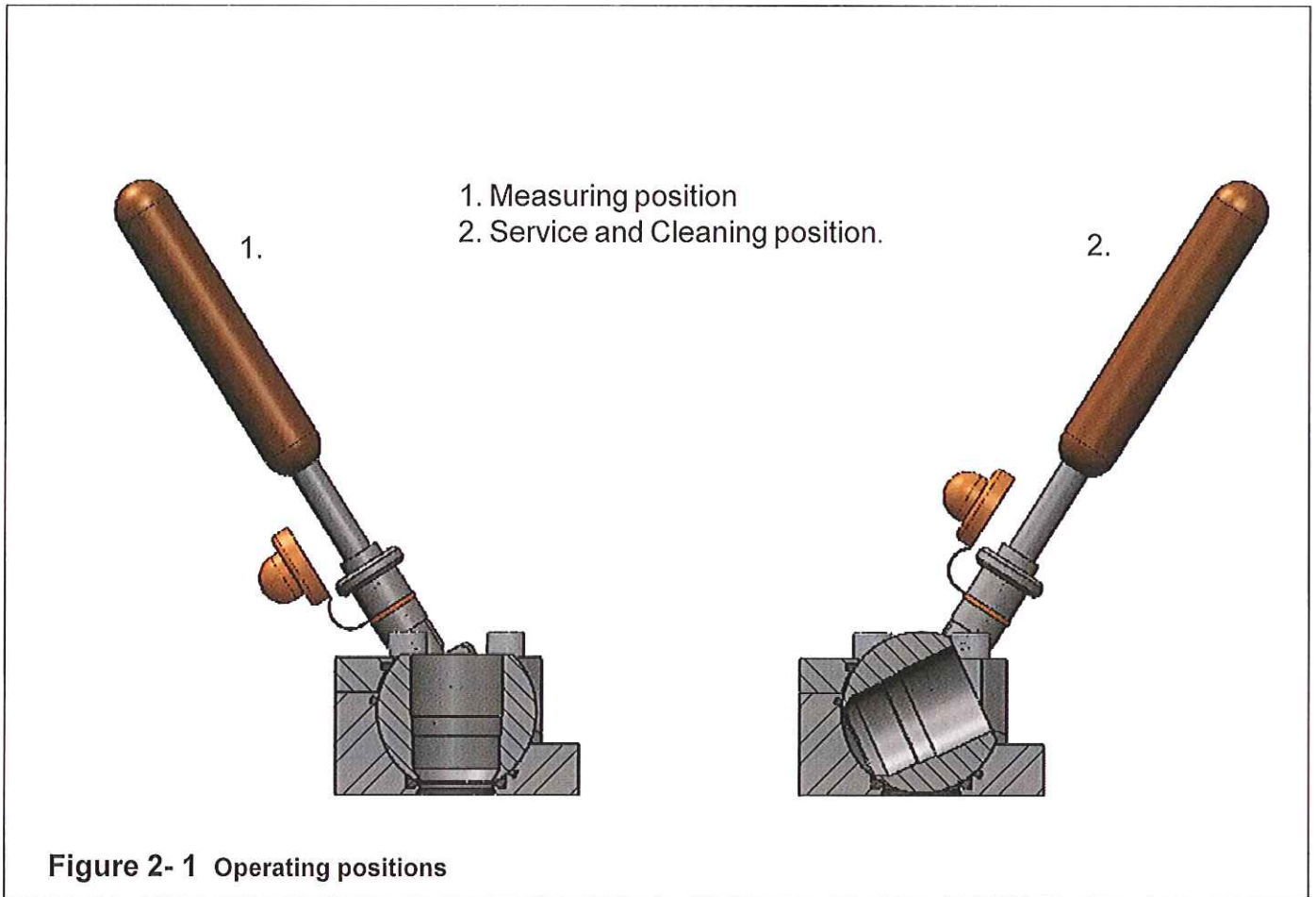

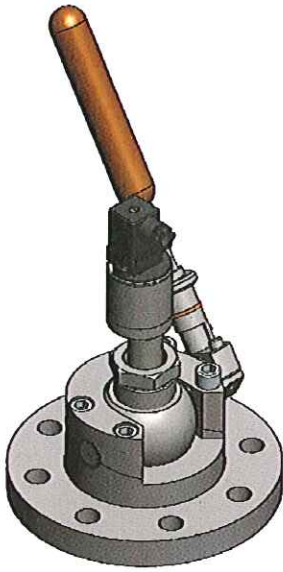

PASVEBAF
- Flange type
- Manually operated (MD)

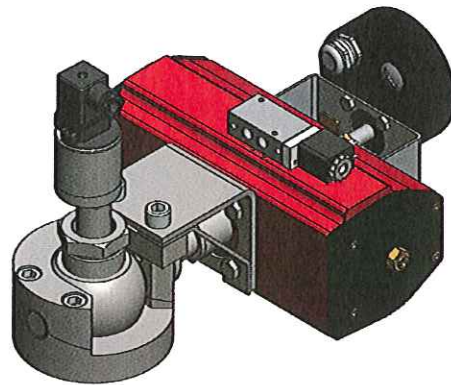

PASVEBAC
- Welded on container
- Double-action actuator (AD)

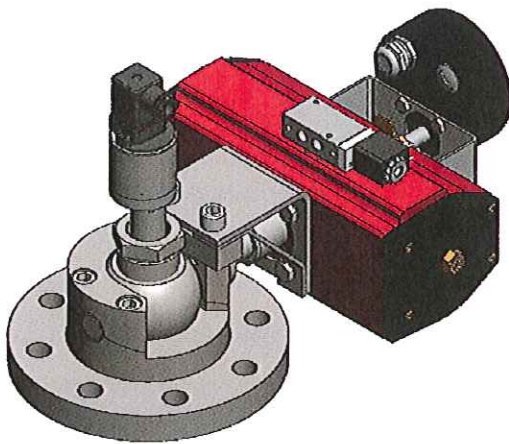

PASVEBAF
- Flange type
- Double-action actuator (AD)

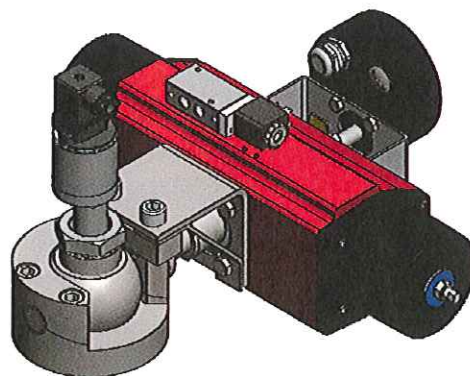

PASVEBAC
- Flange type
- Spring-return actuator (AS)

Dimensions (mm)

Manually operated

PASVE BAC

Welded on container

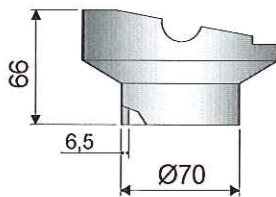
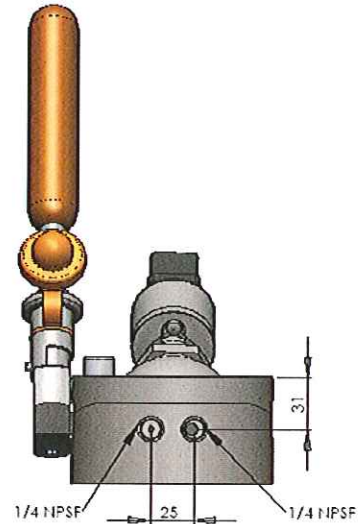
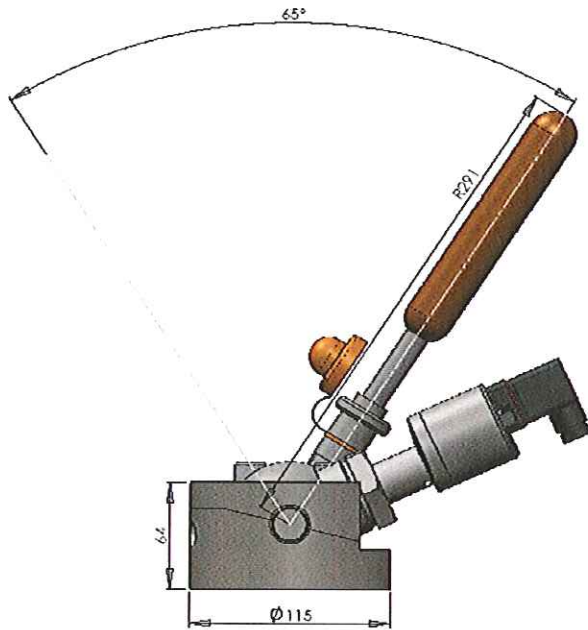

PASVE BAP
Welded on pipe

Flange (a)		ØD	Ød	A
Code	Type			
A	ANSI 3" 150 lbs	191	152.4	22
B	ANSI 3" 300 lbs	210	168.3	27
H	ANSI 4" 150 lbs	229	190.5	26
G	ANSI 4" 300 lbs	254	200	29
D	DN80 PN40	200	160	22
J	DN100 PN10/16	220	180	22
C	DN100 PN40	235	190	26
E	JIS10K 80	185	150	20
F	JIS40K 80	210	170	30

PASVE BAF-(a)
Flange type

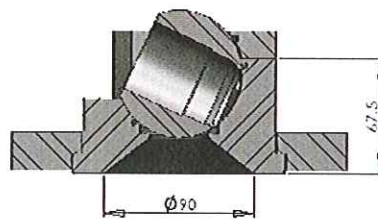
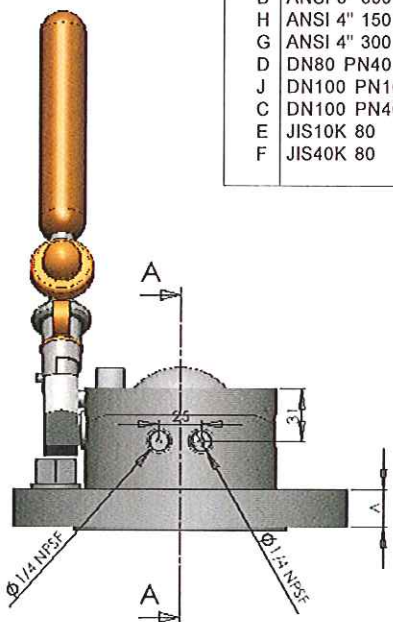

SECTION A-A

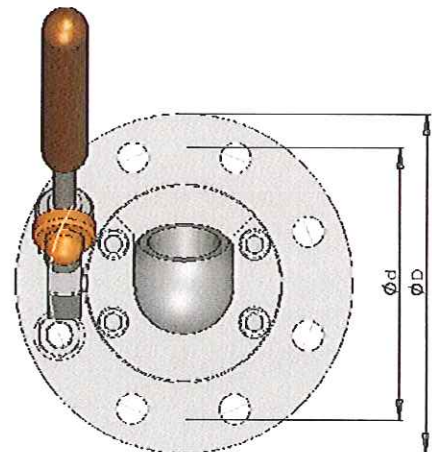

Dimensions (mm)

Automatic operated with actuator

PASVE BAC

- Welded on container
- Double-action actuator (AD)

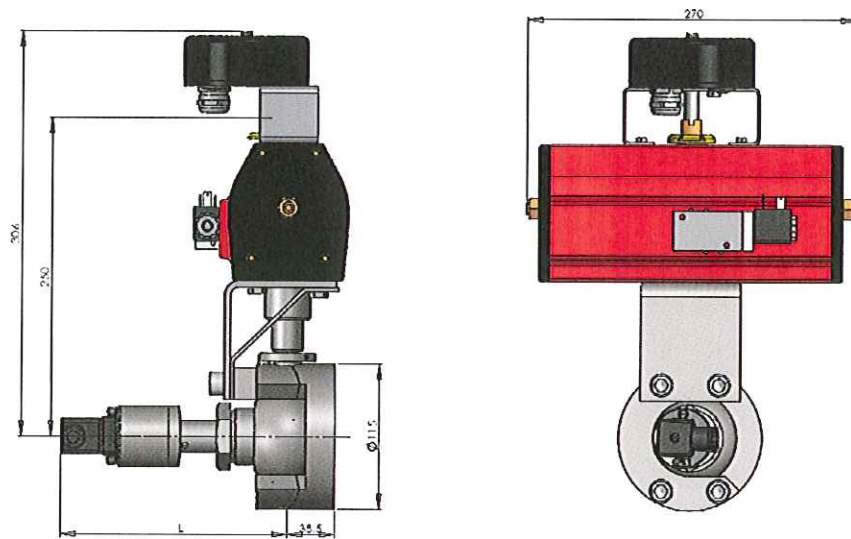

PASVE BAC

- Welded on container
- Spring-return actuator (AS)

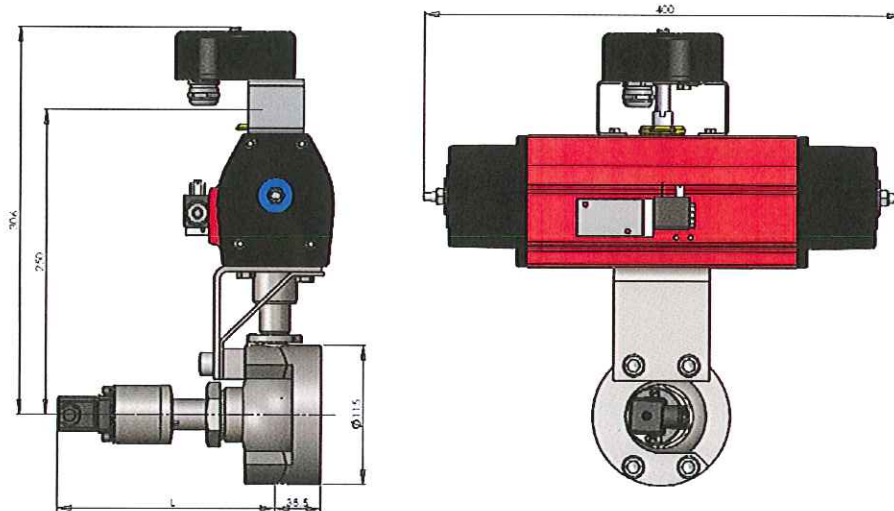

PASVE BAF

- Flange type
- Double-action actuator (AD)

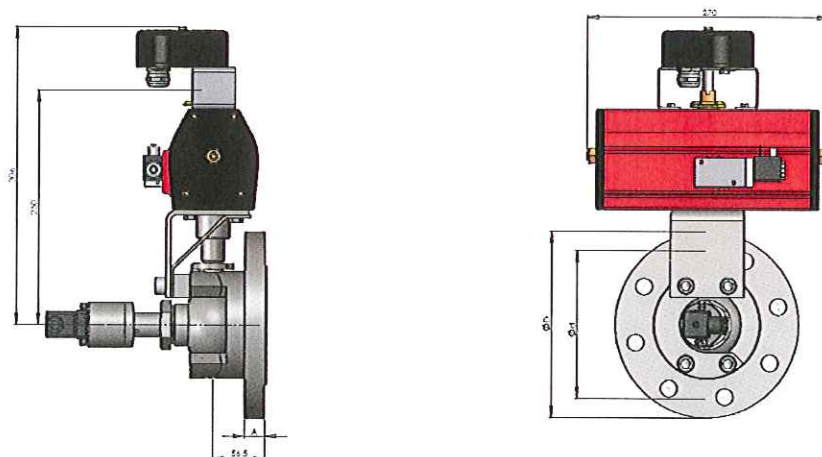

3. Installation

3.1 Mechanical installation

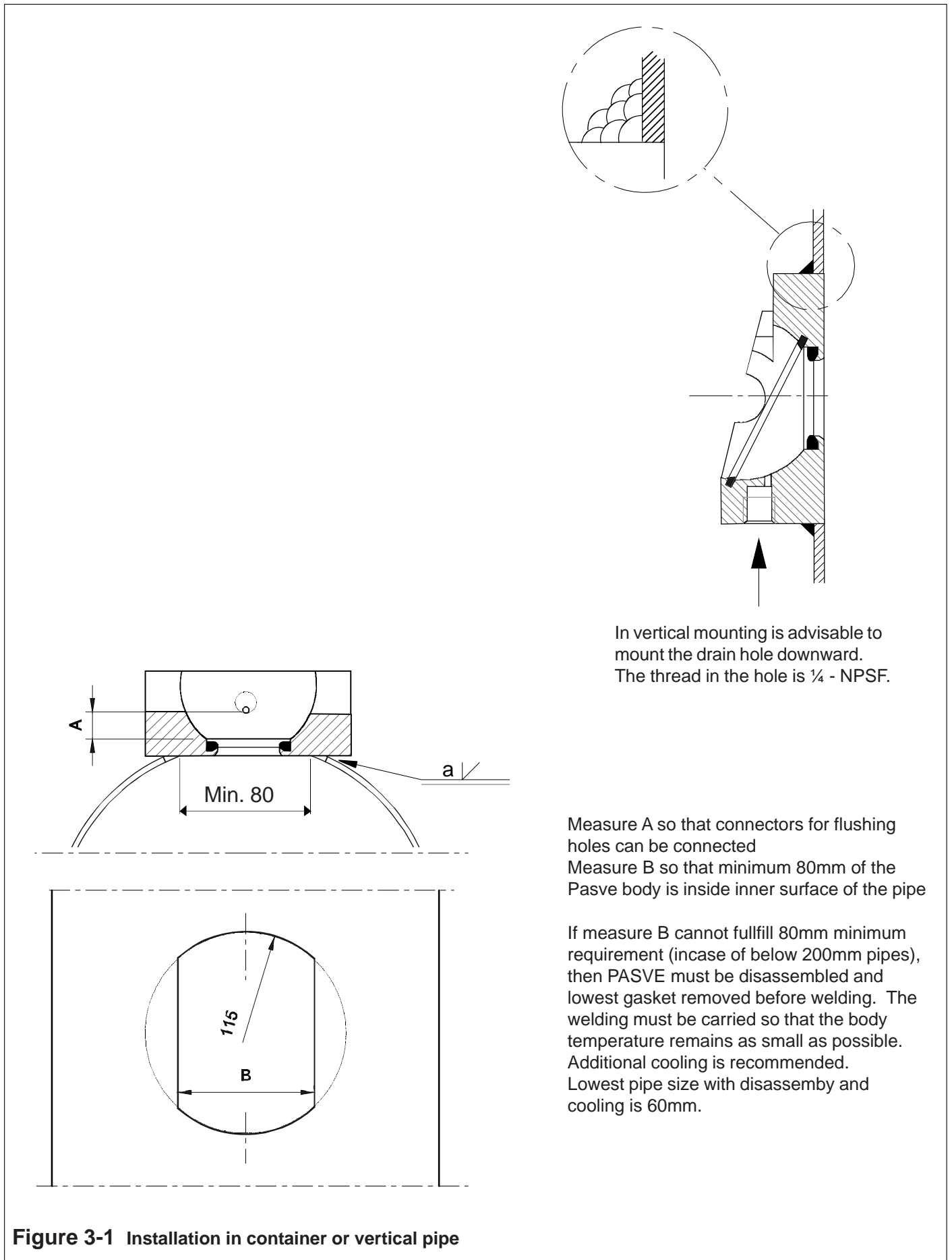
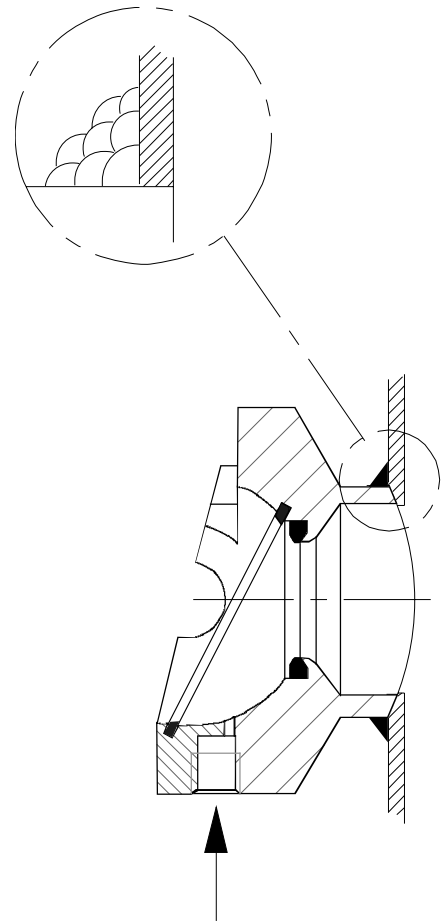
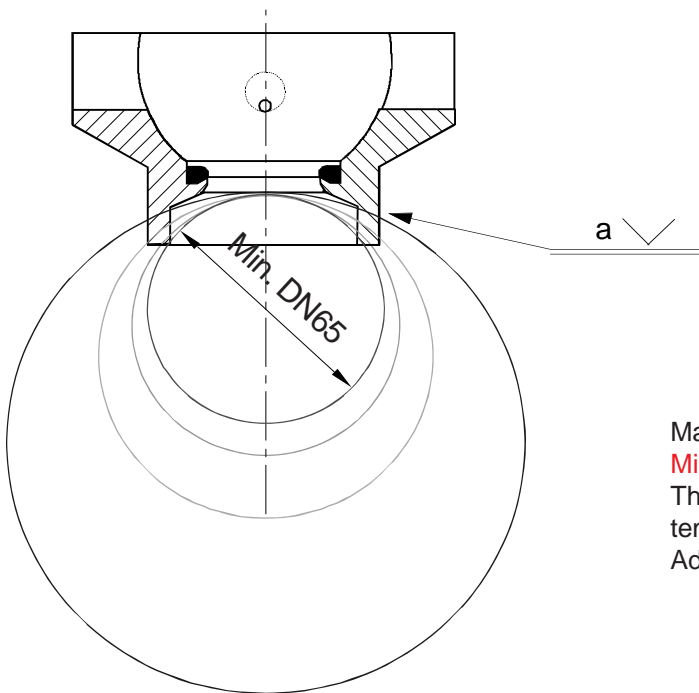

Figure 3-1 Installation in container or vertical pipe



In vertical mounting is advisable to mount the drain hole downward.
The thread in the hole is 1/4 - NPSF.



Machine the Pasve to the same diameter as the pipe.
Minimum pipe size is 70 mm.
The welding must be carried so that the body temperature remains as small as possible.
Additional cooling is recommended.

Figure 3-3 Install body P in the pipe

3.2 FLUSHING INSTALLATION

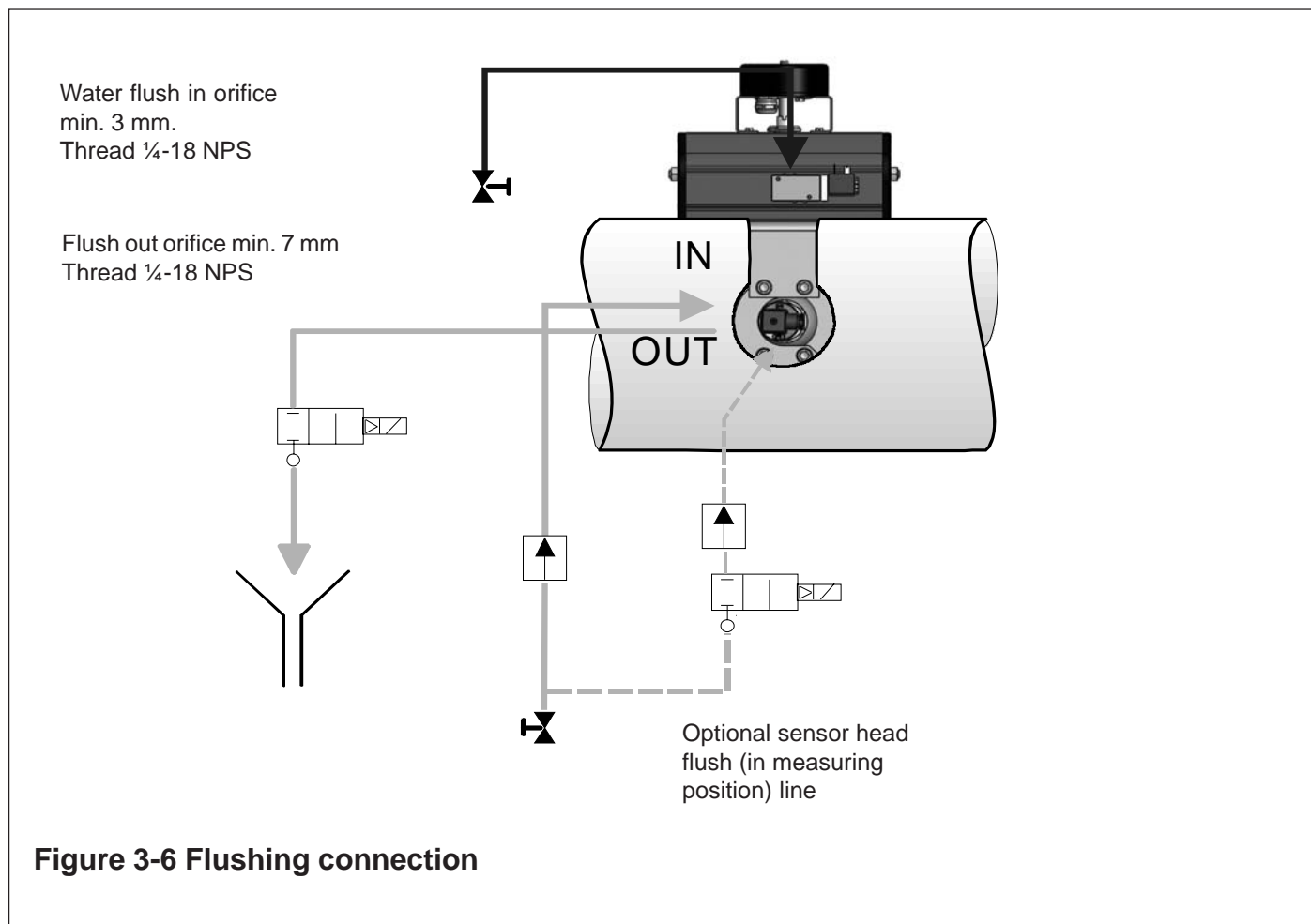

3.3 COMPRESSED AIR INSTALLATION

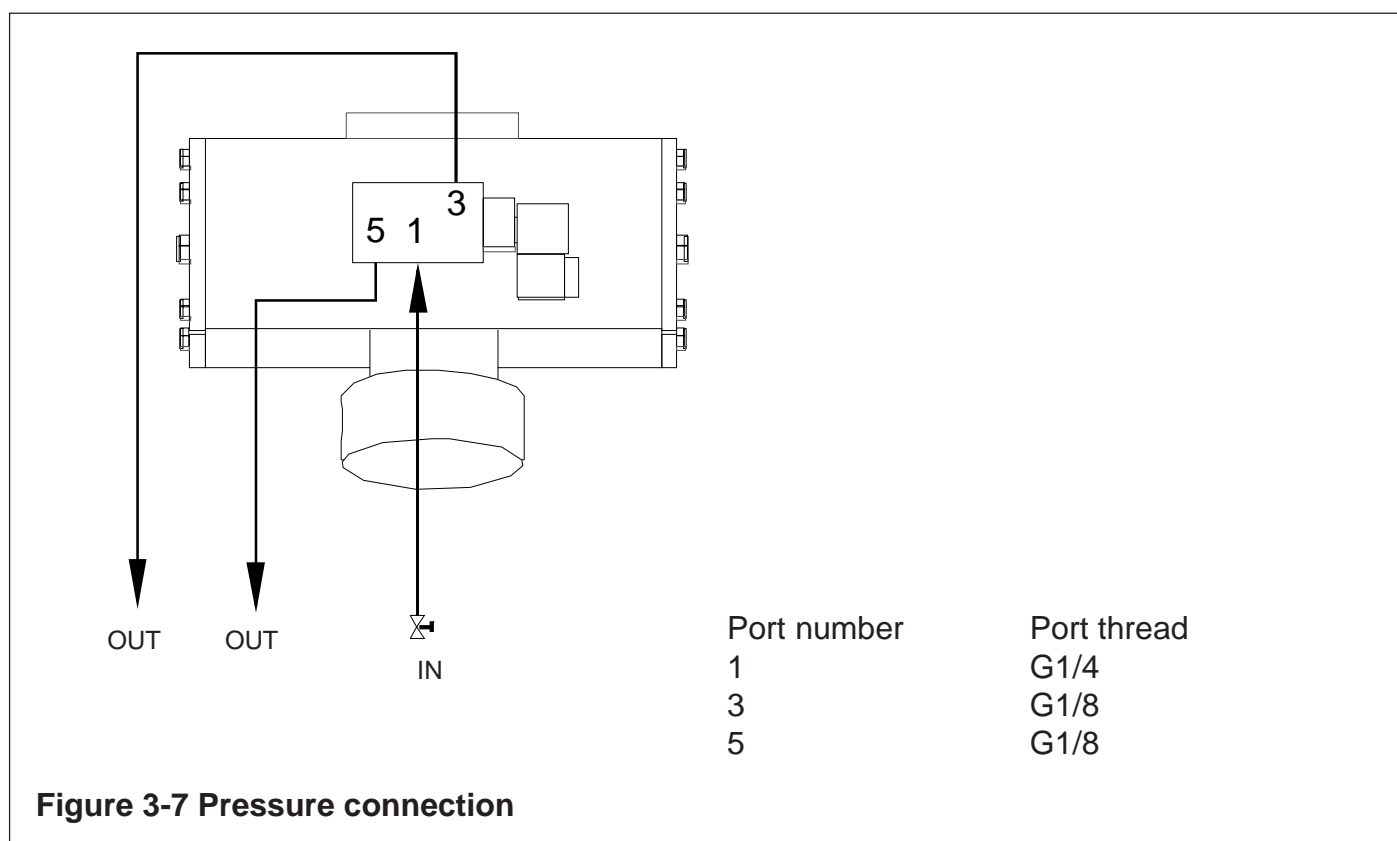

3.4 ELECTRICAL CONNECTION

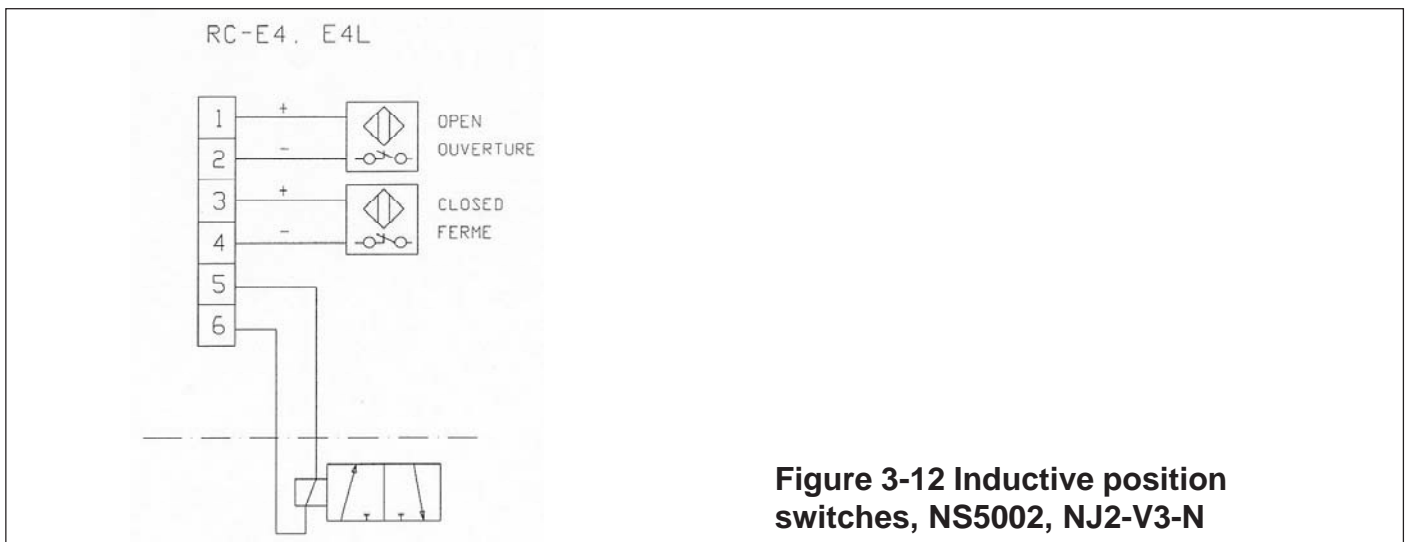
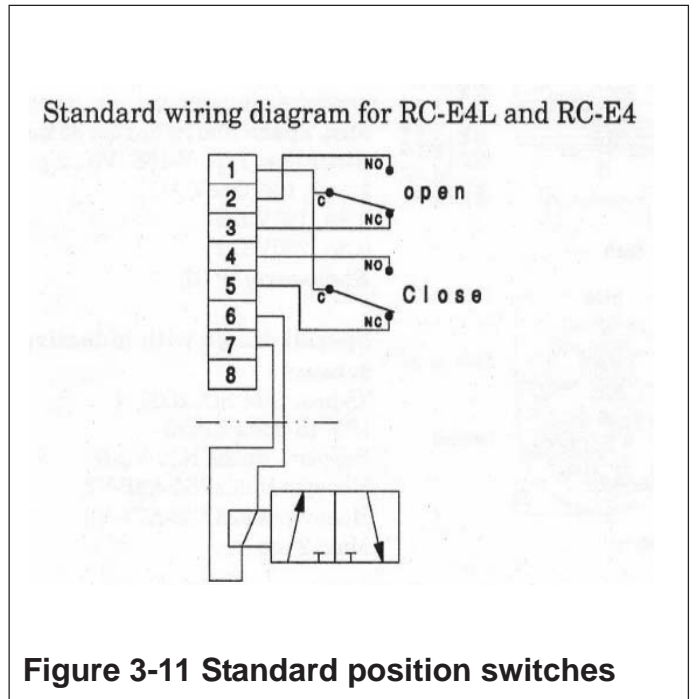
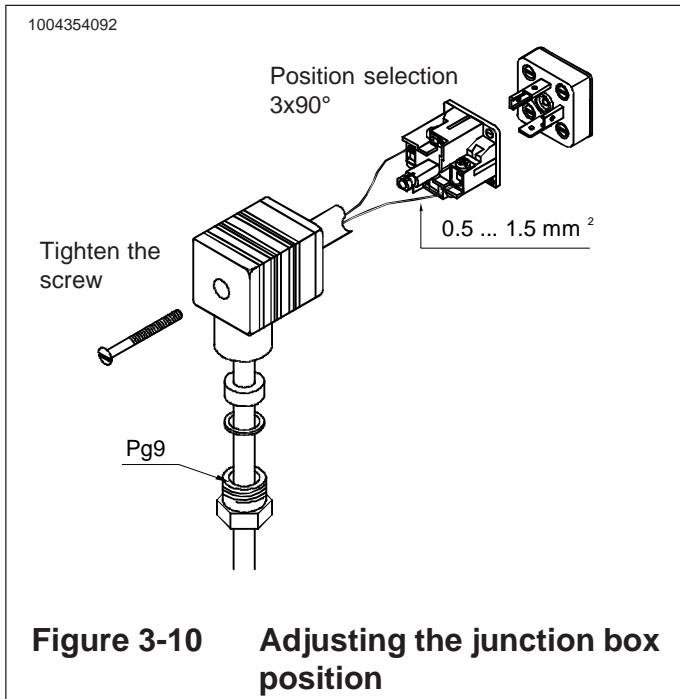
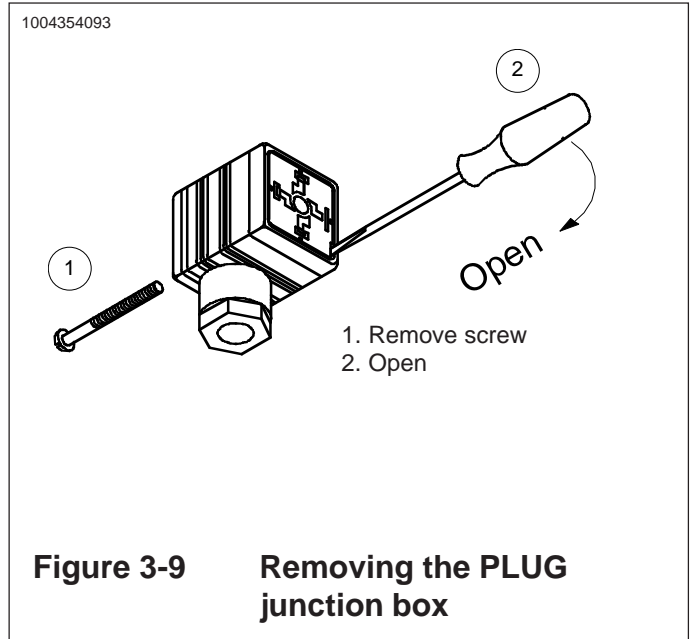
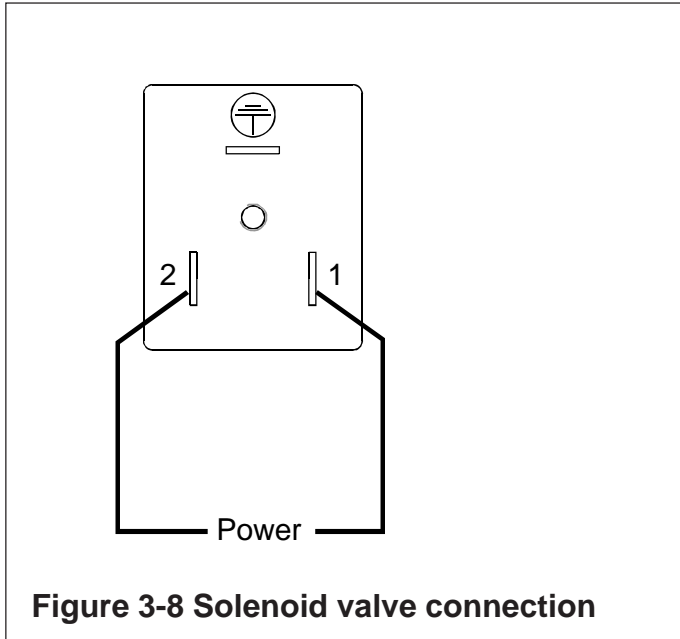



www.bernard-actuators.com

Type	Torque Nm	Closing time secs/ 90°	Motor single phase	P kW	In A	I _s A
OAB	80	6	230 V 50 Hz	0,03	0,6	0,9
OAB	80	6	230 V 50 Hz	0,10	1,2	1,7
OAP6	80	30 or 60	230 V 50 Hz	0,03	0,6	0,9
DA15	150	15 or 25	230 V 50 Hz	0,03	0,6	0,9

WIRING S2242-A

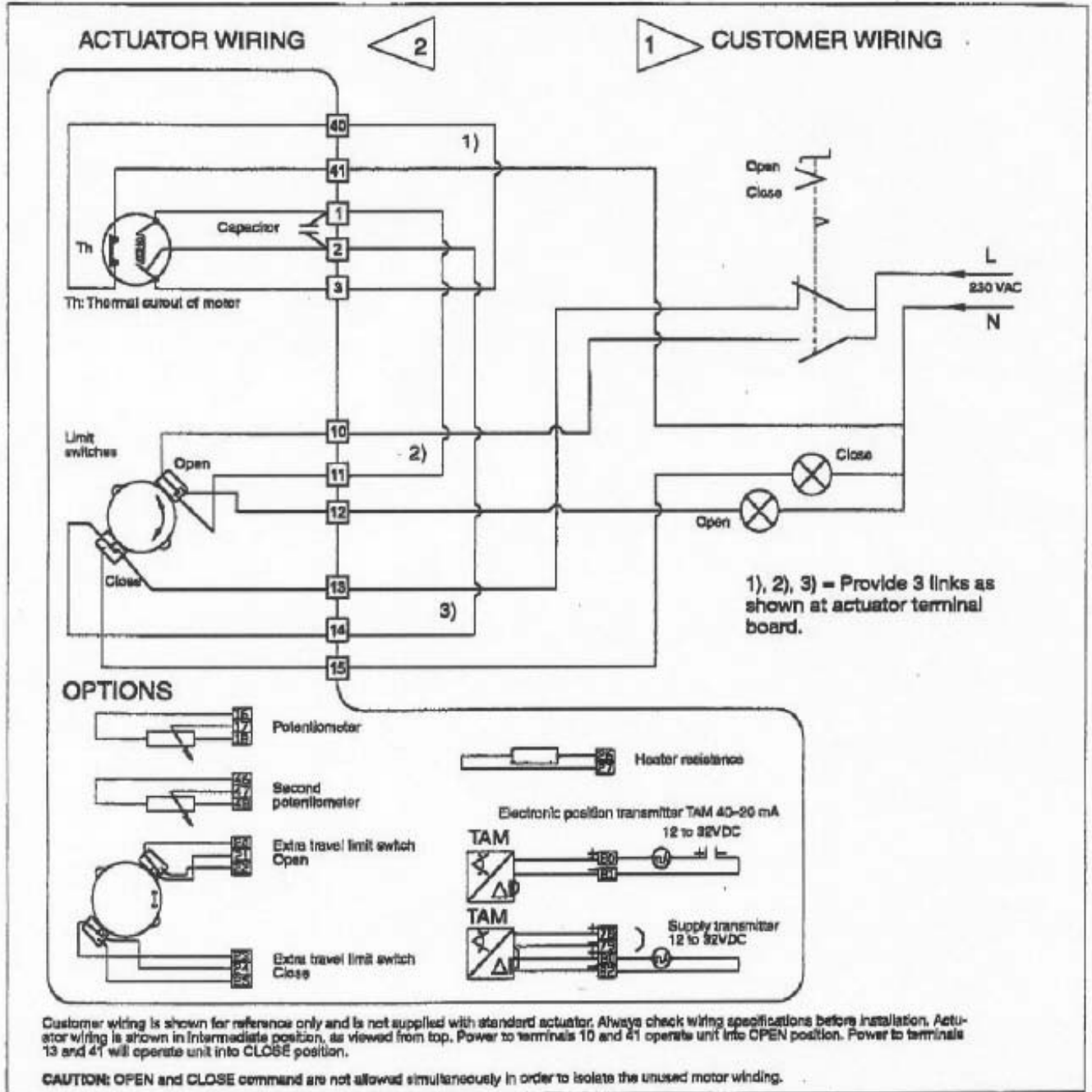

Figure 3-13 Electric actuator connection

4 SETTING-UP

Transmitter installation to Pasve

- Pasve must be in service/flushing position, manual valve **A** must be closed and solenoid valve **B** open.
- Install the transmitter to Pasve.
- Close solenoid valve **B** and open manual valve **A**.
- Turn Pasve ball to the measuring position.

Figure 4-1 Setting-up Pasve with flushing

Flushing the diaphragm of the transmitter in the Pasve

1. Turn PASVE ball to flushing position. (solenoid valve **B** is closed and manual valve **A** open.
2. Open solenoid valve **B** for flushing and the valve **A** must be open.
3. When the diaphragm is clean close the solenoid valve **B**, let the manual valve **A** to be open.
4. Turn PASVE ball to the measuring position.

Figure 4-2 The diaphragm of the transmitter flushing in the Pasve

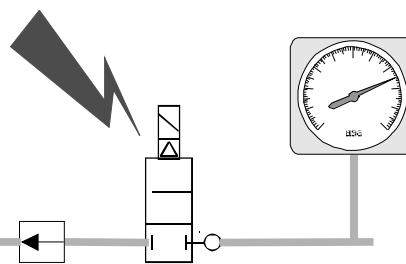
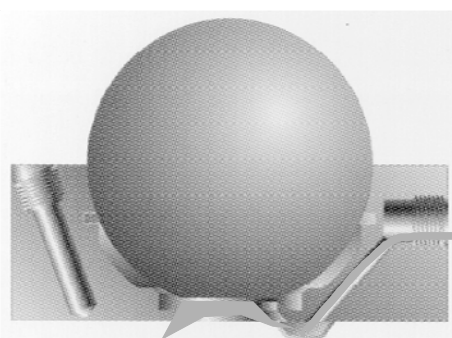

When the process side flushing is needed?

1. Cleaning and flushing of the diaphragm while the transmitter is in the measurement position.
2. Flushing the hollow of Pasve body for e.g. if there is possibly sedimented stuff.
3. Flushing the hollow of Pasve body for e.g. from dirty liquid before turn the ball.

Figure 4-4 Diaphragm of the transmitter process side flushing

5 MAINTENANCE

Replacing the seals

Required tools

- M12 Allen key
- piece of wood to press seal in groove
- sharp, thin screwdriver to remove old seal
- cleaning paper or cloth to clean the grooves

Procedure

1. If PASVE is connected to process, make sure that the container/pipe is empty and unpressurized and, when necessary, flushed.
2. Remove the sensor and valve ball (four M12 Allen screws). Make sure that the bearing parts do not drop off the shaft. When Pasve is equipped with an actuator then it is very important that the other screws will not be opened, because the actuator settings can otherwise be changed, see figure 5-1 part 18 or 24.
3. Remove old sealing with screwdriver. Be careful not to scratch the metal surfaces. Once removed, the old seals will be damaged and useless.
4. Clean the surface and sealing grooves carefully.
5. Place the bottom (smallest) seal in its groove. Correct alignment: the seal's shorter chamfer against the ball, see figure 5-2.
6. Press the seal with a finger as deep as possible in the groove. Then press the seal carefully home with a piece of wood. Since the final pressing requires the use of force, be sure to exert a uniform pressure on the piece of wood to avoid damaging the seal.
7. Check the seals visually: they should be evenly in their grooves without any visible damage.
8. Press new bearing strips and sleeves to the bottom of the shafts. Re-install the valve ball. Note mounting alignment, see the picture Mounting on the back. Grease the Allen screws and tighten them by turns (60 Nm).
9. Check the ball's movement and tightness. At first the ball will move quite stiffly, and moving the ball will require an additional lever arm and solid mounting (the valve must be firmly mounted either in the process or e.g. on a vice bench).

Other considerations:

The type equipped with actuator has two groove seals, one of which is installed on the bearing ring to balance the bearing. Cut from the seal away a piece which is as big as the hole in the bearing ring, see figure 5-1 part 26.

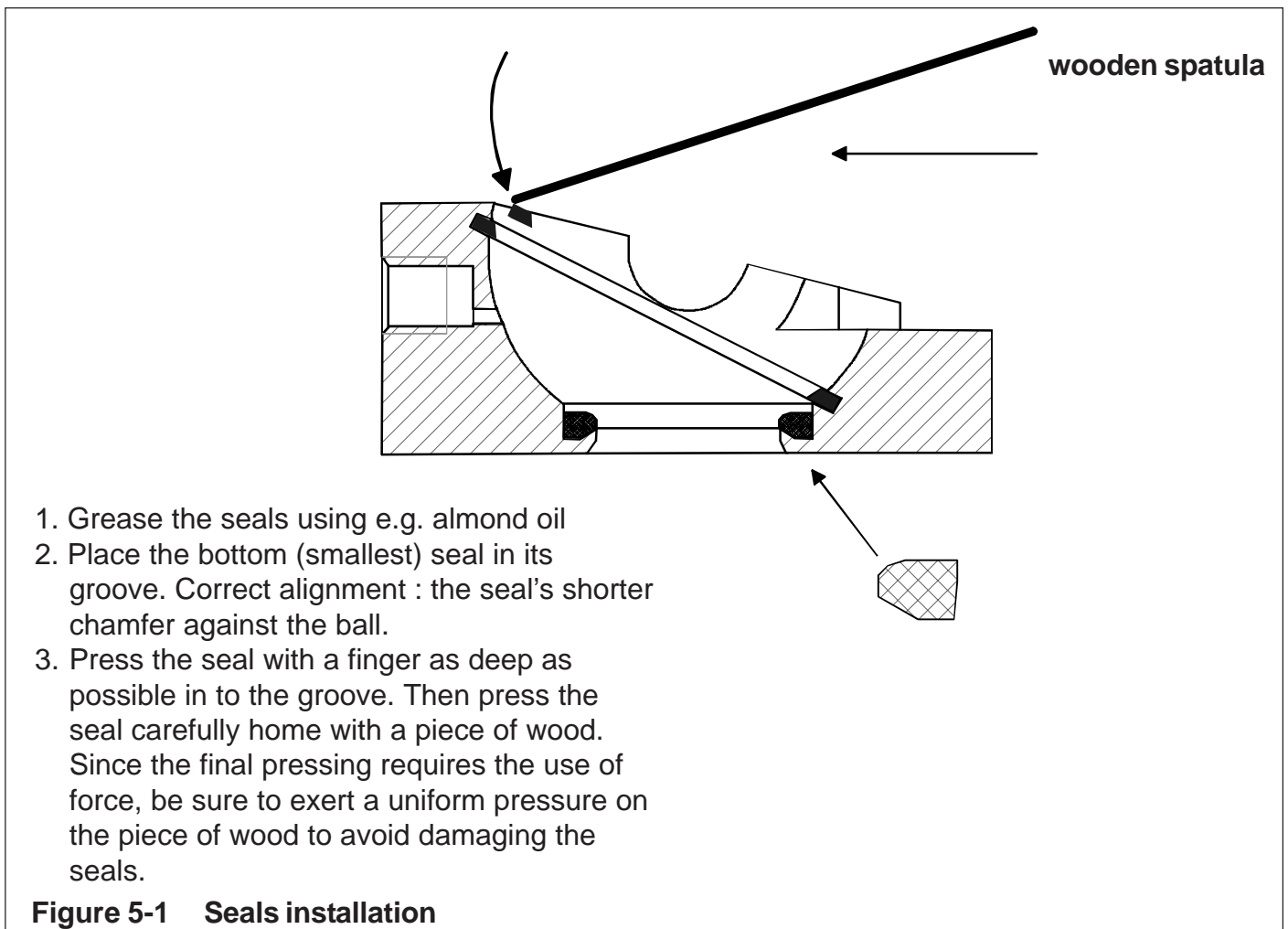

Part no.	Part name	Order code
1	Allen screw M4x6 SFS2219 A4	54426030
2	Lock body	T1015203
3	Pull-out screw	T550974
4	Retaining screw M4x6 DIN915 A4	53282403
5	Locking element 65 deg	T1015208
6	Pasve-spring	85547525
7	Lock screw	T547526
8	Pull-out sleeve	T550975
9	Protecting plug	44547518
10	Lever arm	44547539
Order code for locking piece assembly: (without lever arm, part no. 10)		
Locking piece assembly, 65 deg		T1015020

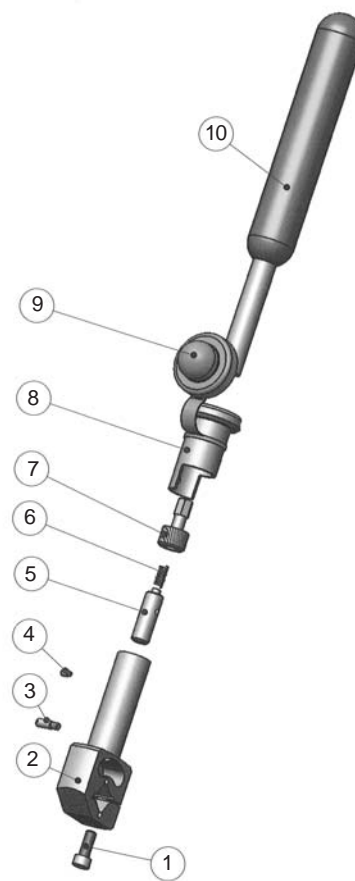

Figure 5-2 Exploder view and part list, locking piece assembly

Part no.	Part name	Order code
1	Body C	T1015201
1	P	T1015212
1	F	T1015211
2	Ball M45, AISI 316L	T1015207
3	Bearing strip	T547516
4	Bearing sleeve	T547529
5	Sealing ring 3 M45	T1015209
6	Sealing ring 1	80547532
7	Cylindrical pin 10x24 ISO6325 A4	57481326
8	Bearing ring M45	T1015202
9	Allen screw M12x40 SFS2219 A4	54428240
10	Allen screw M12x50 SFS2219 A4	54428245
Order code for Pasve mounting valve assembly: (without locking piece assembly and actuator assembly , material AISI316L)		
Pasve BAC200 Pasve BAP200 Pasve BAF0200		MBAC200 MBAP200 MBAF0200

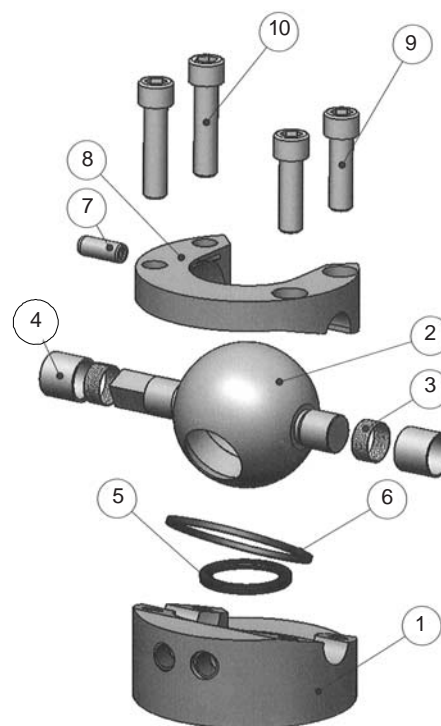

Figure 5-3 Exploder view and part list, Pasve BA mounting valve

Part no.	Part name	Order code
1	Retaining screw M4x6	53322400
2	Liikkeenrajoitin 65 deg	T1015210
3	Switch	T553106
4	Hex screw M8x20 A4	54220820
5	Brace	T552946
6	Brace	T552947
7	Position indicator stand. micro-switch	82920022
	Position indicator Namur-switch	82920028
8	Mounting parts for position indicator	82920019
9	Solenoid valve Lucifer 341N 01	82920031
10	- Coil 2110 220V 50Hz (2W) or - (Coil 488980 3D 230V50Hz (2W))	82920033
	- Coil 488980 6J 110V60Hz (2W)	82920034
	- Coil 488980 C2 24VDC (2.5W)	82920035
	EEx me II T5-coil:	
	- Coil 488980 3D 230V50Hz (2W)	82920037
	- Coil 488980 6J 110V60Hz (2W)	82920038
	- Coil 488980 C2 24VDC (2.5W)	82920040
	Solenoid valve EEx ia IIC T6	82920042
	- Coil 28 V DC 0.4 W EEx ia IIC T6	82920043
11	Actuator bracket	T552945
12	Allen screw M12x70 A4	54428247
13	Spacer	T551008
14	Actuator RC240 DA (double-action)	82920020
	Actuator RC240 SR (spring return)	82920021

Order codes for actuator assembly: (without position indicator, parts no. 7 and 8 and without coil, part no. 10)

Actuator RC240DA + mounting parts (65 deg)	T1015023DA
Actuator RC240SR + mounting parts (65 deg)	T1015023SR

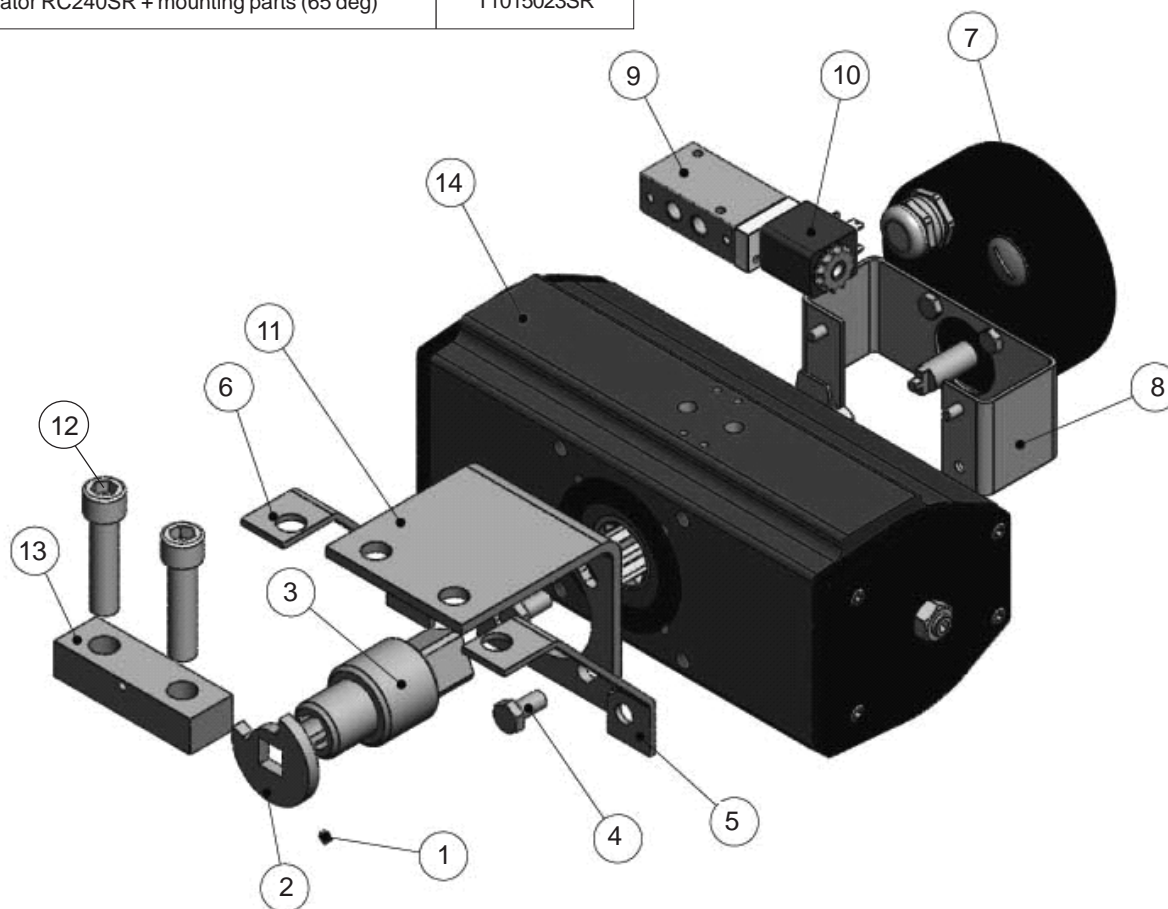
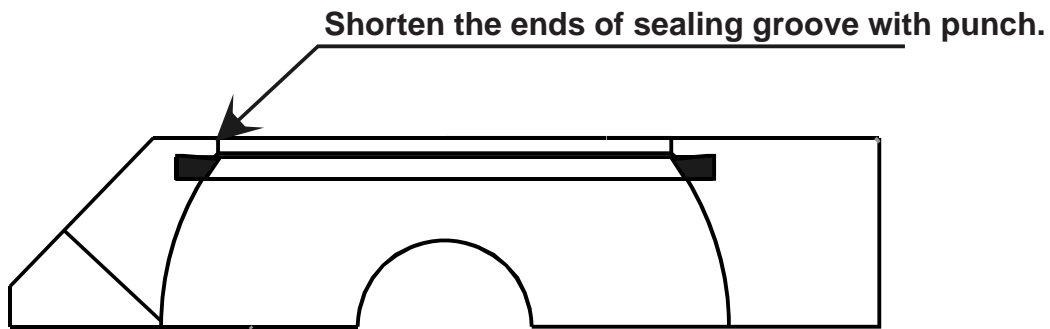
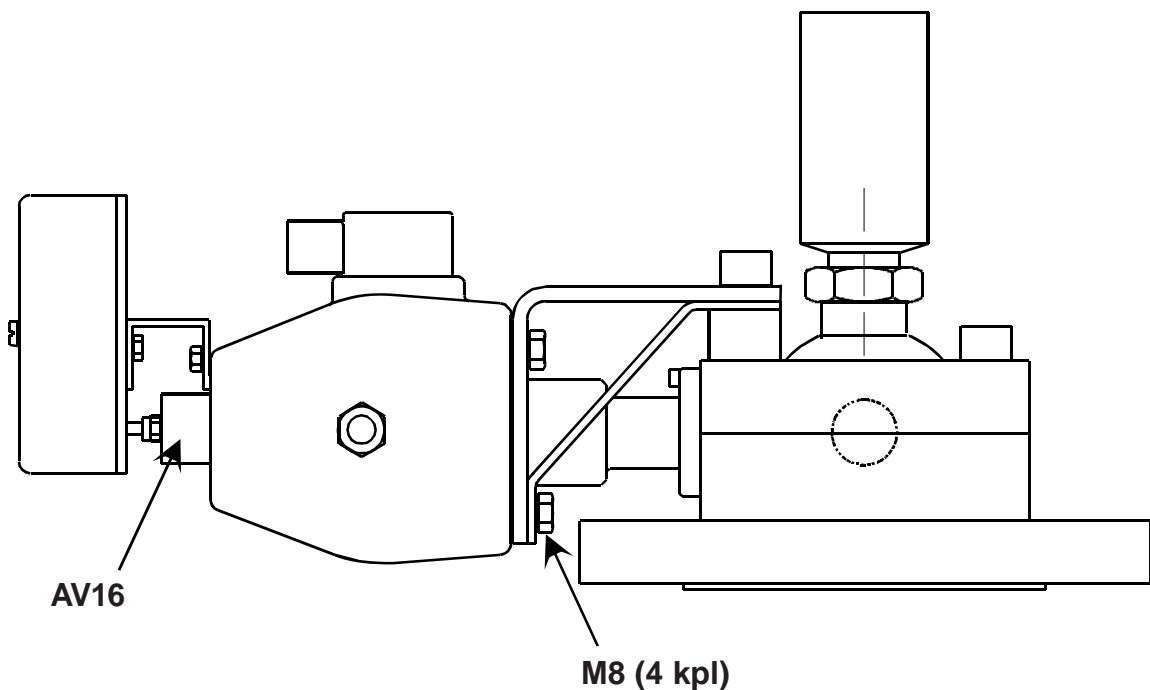

Figure 5-4 Exploder view and part list, actuator assembly



1. Cut from the seal away a piece which is as big as the hole in the bearing ring and set the seal.
2. Shorten the ends of sealing groove with the punch so the seal do not slide from the groove.

Figure 5-5 Back-up seal installation



1. Remove old actuator by opening screws M8 (4 pcs)
2. Fasten new actuator by screws M8.
3. Turn the valve to the measuring position.
4. Loosen screws M8 (4 pcs)
5. Turn the valve to the flushing position.
6. Tighten the screws M8 (4 pcs), torque 60Nm.

Figure 5-6 Changing the actuator



Satron Instruments Inc.

P.O. Box 22, FIN-33901 Tampere

Tel. +358 207 464 800

Telefax +358 207 464 801

www.satron.com, info@satron.com