

Nokeval

No 100211 v1.2

User Guide
Panel meter
models PME600 & PME610



Overview

Panelmeter PME600/PME610 is easy to use. Operatin voltage is 21..265 VAC/DC. Meter supports common temperature sensors thermocouple K, Pt100 and process signals 0..20 mA, 4..20 mA and 0..10 V. Meters settings menu structure is simple, so its easy to setup.

Model PME610 contains analog output 4..20 mA. Model PME600 contains 12V output for 2-wire transmitter.

Technical information

Prosess inputs:	0..20 mA, 4..20 mA and 0..10 V	Alarms:	High and Low alarm.
Display scaling:	-999...9999	Alarm reset:	Automatic or manual via front panel key
Resistance 4..20 mA:	70 Ω shunt resistor is active only when power is on and device is set to mA input	Hysteresis:	Adjustable. Shared with high and low alarm.
Resistance 0..10 V:	110 k Ω	Relays:	2. One for high alarm, one for low alarm. Closing contact
RTD:	Pt100	Relays direction:	Normal open
Range:	-200....+700 $^{\circ}$ C	Contact Rating:	3 A, 250 VAC / 30 VDC (res. Load)
Current:	0,3 mA	Indication lights:	In front panel
Thermocouple:	K	General features	
Range:	-150.... 1350 $^{\circ}$ C	Input filter:	Three samples continues average
mV-input:	-70...70 mV	Speed:	mV, V & mA: ~ 8,3 samples / sec Pt100 & TcK: ~ 3,4 samples / sec
Analog output (PME610):	4..20 mA	AD-converter:	24 bits
max. load:	650 Ω	Indication lights:	Alarms, setup mode
Scale:	Adjustable.	Display:	4-digits bright red LED digit height 14,5 mm
Galvanic isolation from inputs:	No	Operating voltage:	21-265 VAC/DC
Output for 2-wire transmitter (PME600):	12 V, 23 mA	IP Protection class for front panel:	IP65 with gasget
		Weight:	146 g

Sensor break in tcK or Pt100, appears hyphens (---) in the display and high alarm closing and low alarm opening.

INSTALLING

This chapter guide to install 1/8 DIN-size panelmeter PME600/PME610.

Panel installation

Panelmeter should be mount to panel cutoff according to below picture. Attach the meter with two holders supplied.

Dimensions

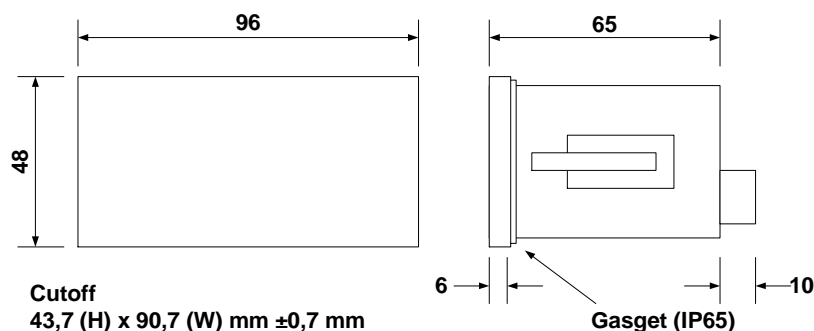

Wirings

Meter has three or four (depending the model) removable screw connector. One green 6-pin connector for input and one green 2-pin connector for mA output (PME610). One grey 4-pin connector for relays and one grey 3-pin connector for power supply. Green connector may used only with safety extra-low voltage. Analog output is not galvanic isolated from input. Shunt resistor for current input is internally connected only when power is on and input sensor is set to 0-20 mA or 4-20 mA.

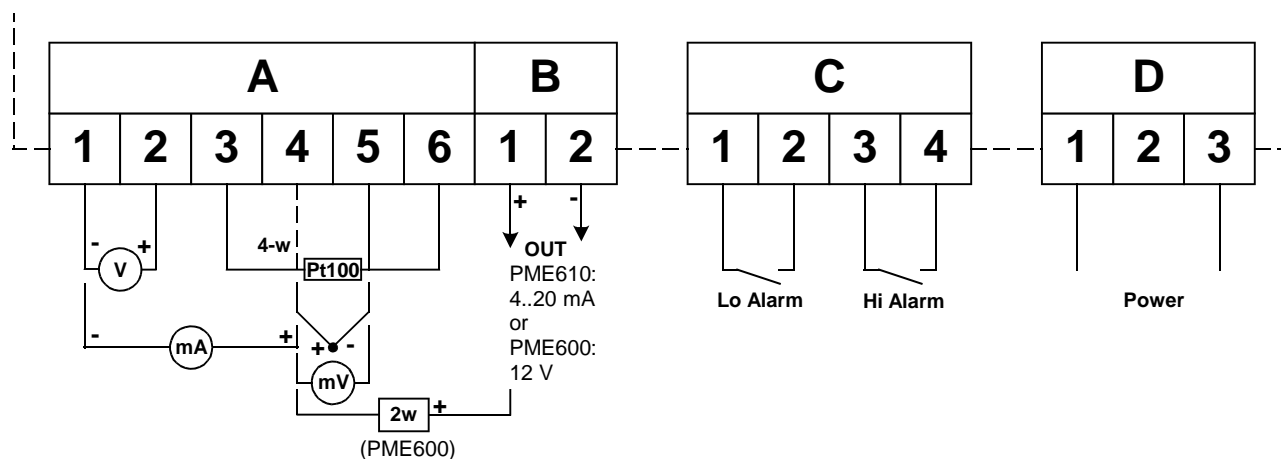

Operating voltage

Connect power supply to pins D1 and D3. No polarity. No ground needed. The meter has internal pre-fuse. If an external is used, it should be at least 500mA.

USER INTERFACE

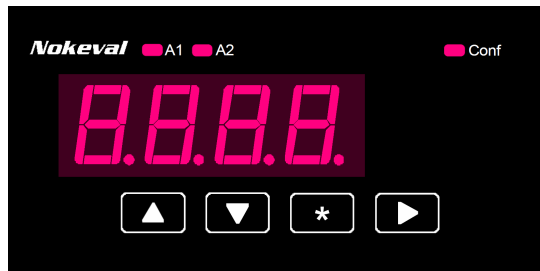

Front panel

There is two modes:

- Normal mode – Shows reading.
- Setting mode – For changing the settings.

After switching the power on, the userinterface is in normal state, indicating readings.

Indicator LEDs A1 (low alarm) and A2 (high alarm) indicate the state of alarms. Conf LED is lighting when user interface is in setting mode.

Manual reset with front panel ▼-key can be selected by choosing wider hysteresis than full span.

Setting mode

Entering

In the normal mode press *- and ▲-buttons simultaneously until conf LED start lighting.

Navigating

Within menu you can navigate up and down using the ▲▼-buttons.

Editing

Pressing the ►-button shows the value of the settings and allows editing it.

Most data types are edited simply with ▲▼-buttons and exited with *-button.

Floating point numbers are edited using the ▲▼►-buttons. Select the digit to be edited or the decimal point with ►-button and edit it with ▲▼-buttons. The first digit can be edited to a minus sign.

Exiting

When all done, exit from setting mode with *-button. Select ▲▼ Save (keep the changes) or Undo (discard the changes) and press ►.

Keylock

It is possible to prevent access to the setting mode by setting a jumper as shown :

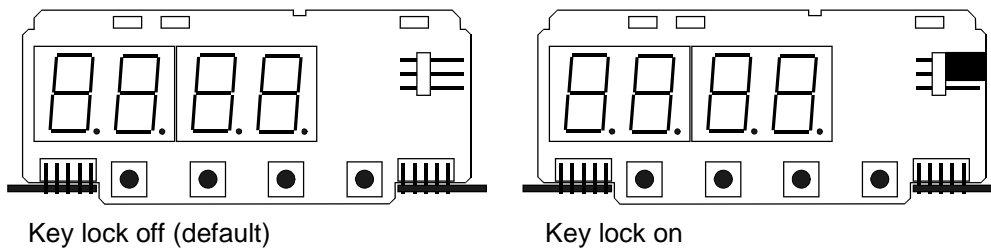

Flow diagram

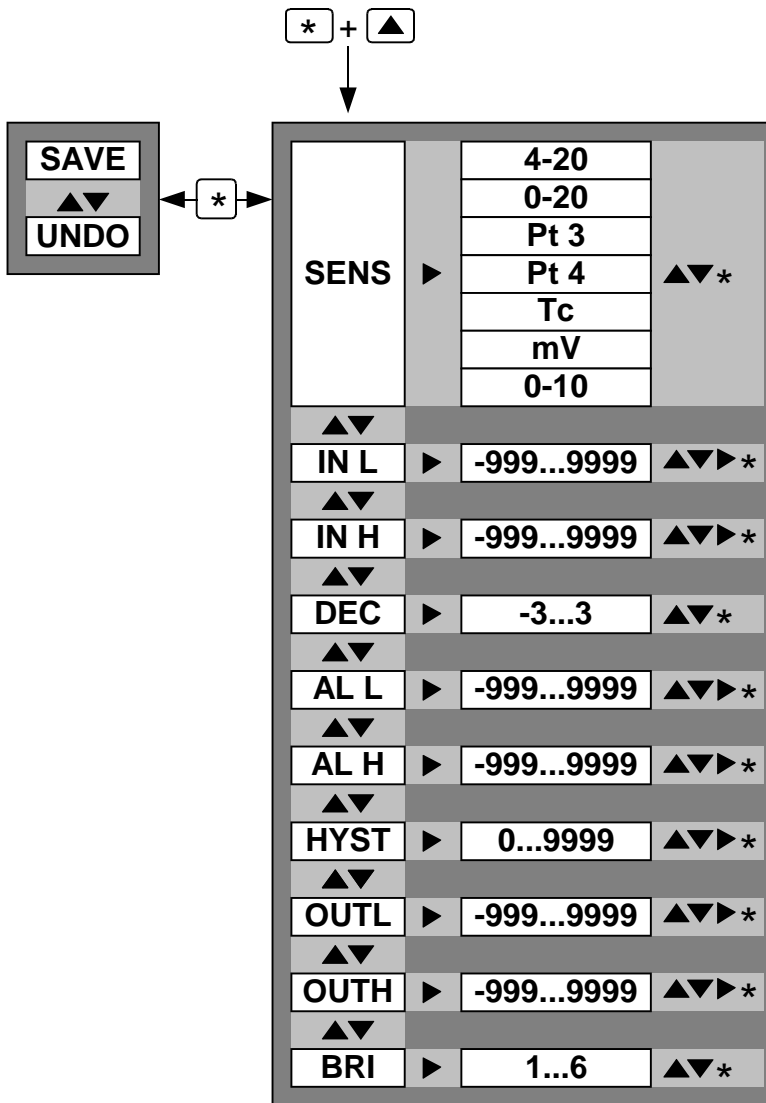

Input selection
 4-20 = 4...20 mA
 0-20 = 0...20 mA
 Pt 3 = Pt100 3-wire
 Pt 4 = Pt100 4-wire
 Tc = Thermocouple K
 mV = Millivolts
 0-10 = 0...10 V

Display scaling for V- and mA-inputs:
 Reading when input is in min. level.

Display scaling for V- and mA-inputs:
 Reading when input is in max. level.

Positive value: decimals.
 Negative value: rounding to zero

Low alarm level

High alarm level

Hysteresis level

Output scaling: Display reading
 corresponding 4 mA output.

Output scaling: Display reading
 corresponding 20 mA output.

Display brightness

Output settings OUTL and OUTH are visible only in model PME610.

Auto reset is a standard function. Manual reset with front panel ▼-key can be selected by choosing wider hysteresis than full span (Hi -Lo). For example: Input scaling is 0..100,0 i.e. full span is 100. Select hysteresis larger than 100 (9999) and you will have manual reset.