

Operating Manual

Dry Block Temperature Calibrator

PULSAR-80CU



INDEX

WARNING.....	3
1 - INTRODUCTION.....	4
1.1 - PURPOSE AND SUMMARY OF INSTRUCTIONS	4
2 - SCOPE OF SUPPLY	5
2.1 - NAME:	5
2.2 - TECHNICAL DATA:.....	5
2.3 - SERVICE (FUNCTION):	6
2.4 - QUANTITY:	6
2.5 - CONSTRUCTOR:	6
2.6 - N° OF CORRESPONDENT CATALOGUE SHEET:.....	6
2.7 - LIST OF FIRST EQUIPMENT ACCESSORIES:	6
3 - GENERAL RECOMMENDATIONS.....	7
4 - SAFETY INSTRUCTIONS	9
5 - PREPARATION OF OPERATION.....	10
5.1 - INSTALLATION.....	10
5.1.1 - Removal of packaging.....	10
5.1.2 - Positioning the calibrator	10
5.1.3 - Supply.....	10
6 - OPERATION PROCEDURE	12
6.1 - OPERATION DESCRIPTION	12
6.2 - DESCRIPTION OF INSTRUMENT	12
6.2.1 - Thermoregulator.....	12
6.2.2 - Main switch.....	12
6.2.3 - Carrying handle.....	12
6.2.4 - Heating resistance	12
6.2.5 - Equalising block.....	13
6.2.6 - Temperature sensors.....	13
6.2.7 - Safety thermostat.....	13
6.3 - START-UP INSTRUCTIONS	14
6.4 - USE OF THE FUNCTIONS.....	16
6.4.1 - Reading the external probes (only for model -2I).....	16
6.4.2 - Switch test (SW. ON SW. OFF).....	17
6.4.3 - Serial communication	17
7 - MAINTENANCE INSTRUCTIONS.....	17
7.1 - ROUTINE INSPECTIONS INSTRUCTIONS.....	17
8 - SEQUENCE OF MAINTENANCE.....	17
9 - TYPICAL FAULTS	18
10 - APPENDICES.....	19
10.1- REGULATION FRONT PANEL	19
10.2 - MICROPROCESSOR REGULATOR: CONTROL DESCRIPTION.....	25
10.3 - COMMUNICATION PROTOCOL RS232/C	26
10.4 - LIST OF SPARE PARTS	29
10.5- DECLARATION OF CONFORMITY AND CHECK REPORT	29
10.6 - DRAWING AND WIRING DIAGRAM	29

**WARNING**

Hazardous voltages are present in this electrical equipment during operation. Non-observance of the safety instruction can result in severe personal injury or property damage.

Only qualified personnel should work on or around this equipment after becoming familiar with all warnings, safety notices, and maintenance procedures contained herein. Only qualified personnel or our personnel should work on this equipment for maintenance operation.

The successful and safe operation of this equipment is dependent on proper handling, operation and maintenance.



Electrical and electronic equipments with this symbol cannot be thrown away in public dump sites. According to the EU directive 2002/96/EC, the European users of electrical and electronic equipment have the opportunity to return to the distributor or manufacturer used equipment purchasing a new equipment. The illegal disposal of electrical and electronic equipments is punished by pecuniary administrative sanction.

SYMBOLS BEING USED IN THIS MANUAL OR ON THE INSTRUMENT

CAUTION: HOT SURFACE OR PART



CAUTION: REFER TO ACCOMPANING DOCUMENTS



CAUTION: RISK OF ELECTRICAL SHOCK

Note:

In this manual: where not specified, the numbers in parentheses make reference to the annexed drawing.

1 - INTRODUCTION

1.1 - Purpose and summary of instructions

This manual contains instructions for use and maintenance of the family of temperature calibrators PULSAR.

MODELS:

PULSAR-80CU

The instructions reported in this manual, for the above-mentioned equipment, are those relevant to:

- * Start-up preparation
- * Operation description
- * Using of the equipment
- * Re-calibration procedure
- * Preventive maintenance
- * Typical faults and ways of their remedies

Users must observe all the usual safety rules out in this manual for own security and to avoid equipment failure.

2 - SCOPE OF SUPPLY

2.1 - Name:

- Portable Temperature Calibrator **LR-Cal PULSAR-80CU**, including accessories, as listed (reference to paragraph 2.7)

2.2 - Technical data:

Environmental range: temperature $+10 \div +45^{\circ}\text{C}$, R.H. max. 90%.

- Operative range : $50 \div 550^{\circ}\text{C}^{**}$
- Stability : $\pm 0.05^{\circ}\text{C}$ a 450°C^{**}
- Display resolution : 0,01/0,1 $^{\circ}\text{C}$
- Vertical uniformity for 60mm : $\pm 0,1^{\circ}\text{C}(@ 400^{\circ}\text{C})$
- Vertical uniformity for 120mm : $\pm 0,3^{\circ}\text{C}(@ 400^{\circ}\text{C})$
- Vertical uniformity for 180mm : $\pm 0,5^{\circ}\text{C}(@ 400^{\circ}\text{C})$
- Horizontal uniformity for two opposite holes of 6mm. : $0,1^{\circ}\text{C}(@ 250^{\circ}\text{C})$
- Heating rate : $9 \div 10^{\circ}\text{C}/\text{min.}^{**}$
- Cooling rate : $1 \div 3^{\circ}\text{C}/\text{min.}^{**}$
- Time for stability from 30 to 400°C : 40'
- Reading accuracy : $\pm 0,3^{\circ}\text{C}$ a 250°C
- Regulation & reading probe : Pt 100 class A din43760
- Auxiliary input : Pt100 and Tc J, K, N, R, S, E(only for Model 2I)
- Reading : $^{\circ}\text{C}$ or $^{\circ}\text{F}$ or K.
- Interface : RS 232
- Thermostat test : 12 Vcc.
- Temperature ramps : minimum $0,1^{\circ}\text{C}/1'$
- Power supply : 230V 50/60Hz
- Power : 1700VA.
- Mx input current : 6,7A
- Well size : $\varnothing 60 \times 270\text{mm}$
- Insert size : $\varnothing 59,5 \times 270\text{mm}$
- Dimensions : $170 \times 330 \times 400\text{ mm}$
- Weight of calibrator : 23Kg

- Customized test insert with drilled holes for best accuracy
- Structure in flanged plate with handle.
- Micro-processor operated temperature regulator.
- Safety thermostat with thermocouple.
- Switch test.
- Internal oven in stainless steel.
- Electronic control components thermally insulated.
- Forced air cooling system.
- Removable upper protection grid.
- Total absence of environmentally harmful cooling liquids.
- Socket with main cable and protection fuses.
- Display back light control.
- Electromagnetic compatibility : Emission EN50081-2
Immunity EN50082-2

NOTE: **The data marked with ** has been recorded at an ambient temperature of $20^{\circ}\text{C} \pm 3$, power supply $230\text{V} \pm 10\%$, with Pt100 $\varnothing 6\text{mm}$ inserted in the block.**
The above-mentioned data keep valid for one year after the issuing of the calibrating certificate; afterwards it is necessary to carry out the oven re-calibration.
Environmental range: temperature $+10 \div +45^{\circ}\text{C}$, R.H. max. 90%.

MICROPROCESSOR DATA

- * Display : 2 lines 20ch x line (3.2x5.5) back lighting.
- * Resolution : 0.01°C/0.1°C.
- * processor : 80C552
- * A/D converter : Σ - Δ 24 bits
- * E2PROM memory for recording parameters.
- * RS232 Single serial output.

2.3 - Service (function):

The portable temperature calibrator **LR-Cal Pulsar-80CU** has been designed for:

- Control & calibration of thermocouples, temperature sensors... , in the laboratory and in the field, in conformity with ISO 9000 standard.
- Thermal test on materials.

The calibrator has been designed to reduce the EMC effect in accordance with the harmonised regulation for residential, commercial, light industry and heavy industry.

N.B: Pulsar endowed with Windows™ Software is designed to:

- ◇ completely check the oven by PC
- ◇ automatically or manually calibrate many probes
- ◇ cyclically check temperature sensor long life or stress condition
- ◇ register and print results obtained according to ISO 9000 standards.

2.4 - Quantity:

- 1 piece.

2.5 - Constructor:

DRUCK & TEMPERATUR Leitenberger GmbH
Bahnhofstr. 33, D-72138 Kirchentellinsfurt, GERMANY

2.6 - N° of correspondent catalogue sheet:

PULSAR-80Cu

2.7 - List of first equipment accessories:

- Standard equipment
 - * PULSAR-80CU calibrator
 - * Electric power cable
 - * Fuse kit
 - * Thermostat testing connection cables
 - * Instructions manual
 - * Calibration certificate traceable to SIT
 - * Tool for removing inserts
- Accessories on request
 - * Special inserts available on request
 - * RS232 cable
 - * Software AQ2sp
- Order code:

PULSAR-80CU	STANDARD VERSION
PULSAR-80CU-2I	VERSION WITH 2 INPUTS
- Certification: all the instruments are supplied with final testing, stability and accuracy certification traceable to Accredia/DAkkS standards.

3 - GENERAL RECOMMENDATIONS

→ ATTENTION

The μ processor regulator has been configured in factory with the parameters suited to work in the respect of the technical specifications.

Don't change these parameters to avoid malfunction or breaking of the calibrator with risks of serious personal injury.

- Position of the probe:

To obtain the best results, follow the advises:

- Measure the diameter of the probe being checked.
- Check that the diameter of the hole in the calibration block is
 - ◊ 0.5mm for $\varnothing 4.5\div 8$ mm probes (max operative range 550°C)
 - ◊ 0.7mm for $\varnothing 8\div 12$ mm probes (max operative range 550°C)
 - ◊ 1mm for $\varnothing 12\div 17$ mm probes (max operative range 550°C)
 - ◊ Reduce this tolerance for max. operative range lower then 550°C
- If this is not possible, use the reduction wells with the above-mentioned tolerances (fig.1).
- Avoid using holes that are too accurate and do not force the probes into the block.
- Put the probe or the insert in the block only at ambient temperature; for reduction insert using the tweezer
- Insert the probe up to the bottom of the block: the sensitive element is in the optimal calibration zone (fig. 2).
- Calibration with a reference: take care to position the two probes, the standard one and the calibration one, at the same dept and as close together as possible (fig. 3).

Always verify the range of the probes to be calibrated before using; the maximum temperature of the probes should be higher then the internal temperature otherwise the probe could break

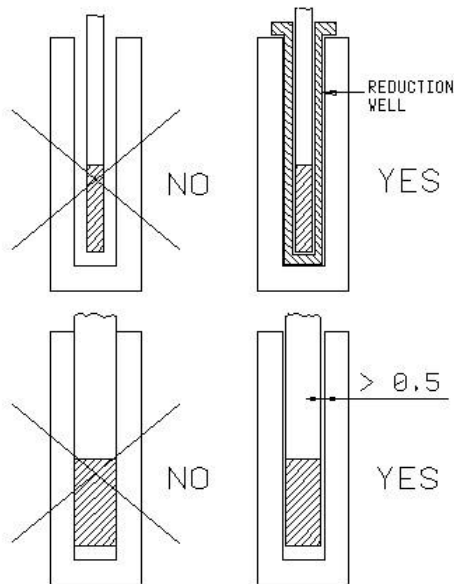

Fig.1

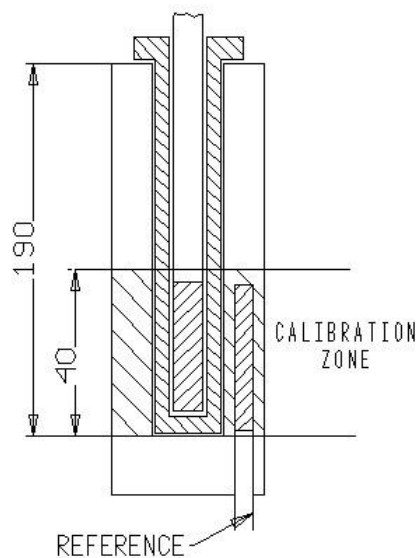

Fig.2

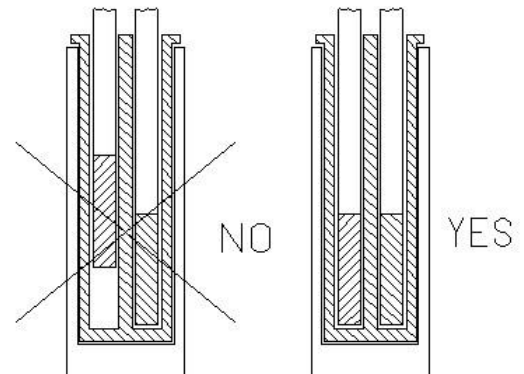

Fig.3

- Advice:

- The temperature difference is proportional to the difference between the diameter of the probe and the diameter of the hole.
- Do not insert the probe when the instrument has already reached the set temperature; thermal shock causes instability and breakage of the sensitive element.
- For the calibration of temperature transducer with special execution, call our technical office and ask for equaliser block with special drillings.

REMEMBER TO SET THE AMBIENT TEMPERATURE AND LEAVE COOL THE CALIBRATOR BEFORE SWITCHING OFF

4 - SAFETY INSTRUCTIONS

ATTENTION:



- Due to the fact that the calibrator is a portable instrument to be used in the field, it is very important to ensure that the socket has been earthen correctly when connecting it to the power supply.
- Carry out the maintenance and repair operation only with the equipment at ambient temperature and disconnected from the electric power.



- Due to the flow of hot air with heated oven, do not block the output of the fan (19)
- During the use of the calibrator, the upper protection grid may overheat.
- Don't touch the probe to calibrate when it's in the block.
- After using wait for the stabilisation at ambient temperature before returning the calibrator to its carrying case. Don't switch off the calibrator when it works at high temperature because the protection grid and the carpentry may overheat.



- If necessary remove the equalizer, always do it with the calibrator at ambient temperature.
- Never put any type of liquid inside the block.
- Don't change absolutely the configuration parameters
- Don't put anything on the top of the calibrator.
- **Do not connect any voltage higher then 5V to the input 4-5-15**
- Don't put fuel objet near the calibrator.
- use common sense any time.

The equipment adopt the following devices to protect operation from hazard:

- Max. temperature safety thermostat (10) to disconnect the heating system.
- Protection grid to avoid any contact with the internal oven.
- Protection fuses (3)
- Ground conductor.

5 - PREPARATION OF OPERATION



- Remove the calibrator from the packaging (5.1.1) and place it on a flat surface (5.1.2).
- Make sure that the instrument has been correctly earthen.
- Supply the oven with line 230V, 50Hz + earth (5.1.3).
- Insert the equalising block into the furnace: reference at the instruction on paragraph 5.1.4
- Before start the calibration read with attention the instruction manual, specially the paragraph 3: - General recommendation.

5.1 - Installation

5.1.1 - Removal of packaging

The calibrator is equipped with packaging suitable for transport and traditional shipping systems. Any damage caused during transport must be notified immediately to the carrier and a claim must be made.

5.1.2 - Positioning the calibrator

Position the calibrator in a safe clean place; leave enough space around the calibrator to allow the air to circulate well.

Use the tool (17) to introduce and remove the insert

****DANGER:** The calibrator is suitable for operating at high temperatures with the consequent danger of fire. Keep it away from any type of inflammable materials and, never put any type of liquid inside the block (reference to paragraph 4)

*** WARNING:** To avoid any smell in the room it is better to switch on the calibrator outside the room for the first time

5.1.3 - Supply

The calibrator runs on a voltage of 230 Vac (115V by request), 50/60Hz.

A 2.5mt. cable is supplied with the calibrator fitted with 2 conductors plus earth.

Make sure that the plant is earthen correctly before switching the instrument on.

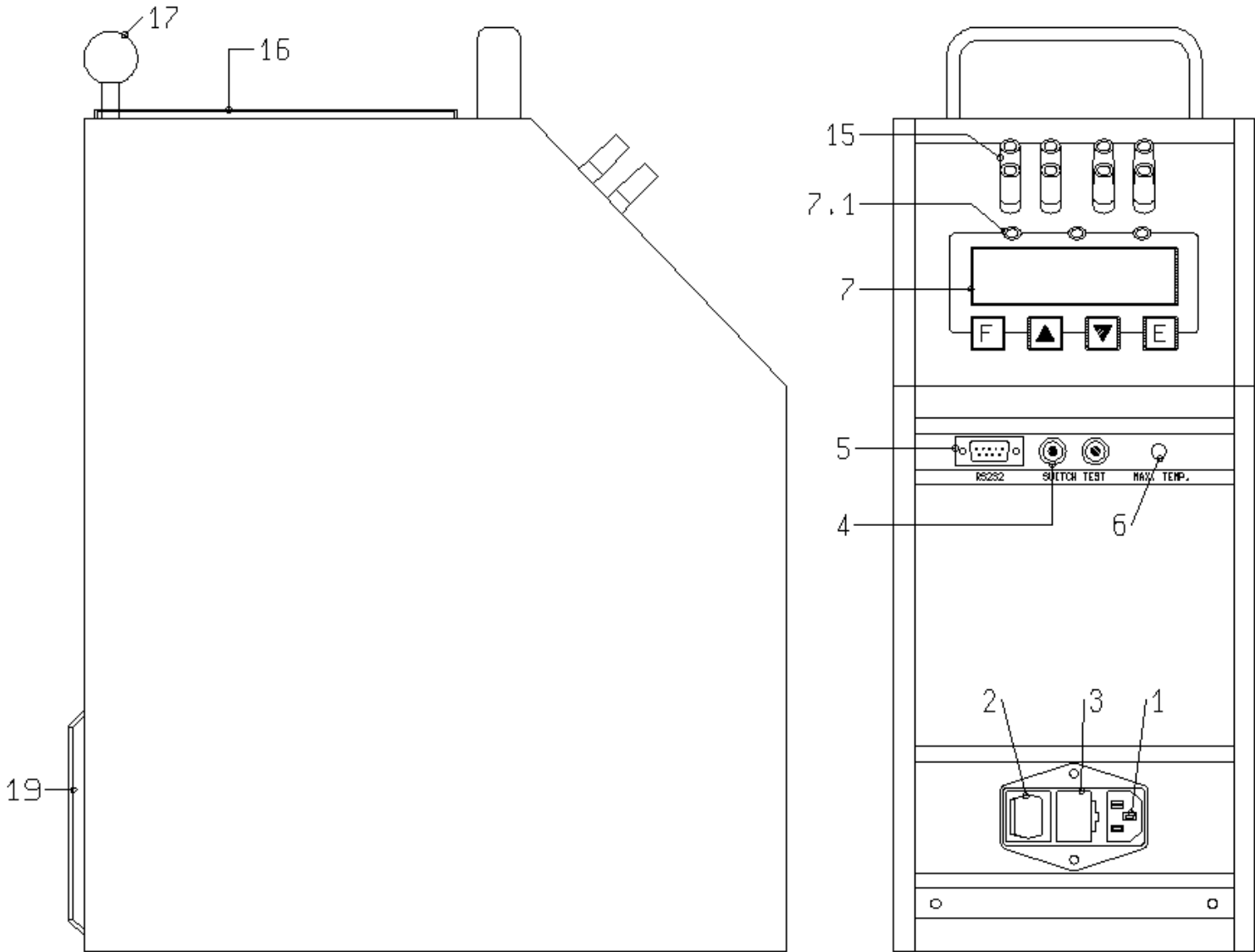

COMMAND LIST

POS.	DESCRIPTION
1	SUPPLY SOCKET
2	MAIN SWITCH
3	PROTECTION FUSES
4	SWITCH TEST BUSHES
5	RS-232 SOCKET
6	MX HEATING LIGHT
7	THERMOREGULATOR +DISPLAY
7.1	LED: HEATING – COOLING – SWITCH TEST
15	EXTERNAL PROBE INPUT (optional)
17	EXTRACTOR TOOL
19	FAN COIL

6 - OPERATION PROCEDURE

6.1 - Operation description

The **PULSAR** calibrator consist of an anticorodal block fitted with holes into which the sensors to be calibrated are inserted.

A heater element heats the block and an electronic controller with Triac output checks and regulates the temperature.

A fan mounted in the rear side generates a constant air flow that reduces the temperature of the case.

6.2 - Description of instrument

6.2.1 - Thermoregulator

The thermo-regulator (7) is a PID microprocessor, which can be set from 0 to 550°C.

- DISPLAY UPPER LINE: indication of the temperature measured inside the block.
- DISPLAY LOWER LINE: indication of the set point; external probes if selected, setting parameters .
- ▲ ▼ KEY: used to increment (decrement) any numerical parameter. The increment (decrement) speed is proportional to the time the key remains depressed.
- F KEY: allow access to the various parameters (repeatedly press), access to the various phases of configuration (press F + ▲).
- E KEY: allow confirming the set parameter.

The calibrator is endowed with eight terminals (optional) that can be set as Pt100 or Tc.

6.2.2 - Main switch

The main switch (2) is fitted with a socket for the voltage cable, the main switch and two fuses as for the following table:

Note: use only fuses F.1A- 5x20mm. All the electrical part is found below the main switch.

6.2.3 - Carrying handle

The calibrator is fitted with a carrying handle .

6.2.4 - Heating resistance

The resistance (13) is stainless steel made; the max. power is 1700W and it can reach temperatures approaching 600°C.

Bear in mind, however, that constant use at extreme temperatures reduces the life of the resistance itself. Limit the number of hours at which the resistance is used at maximum temperatures to the time required by the calibrator in order to prolong the life of the resistance.

6.2.5 - Equalising block

The function of the block is to make the temperature uniform on calibration zone.

If you want to fit the calibrator with a block with different holes we recommend that you should contact the technical support department who will check to see if it is feasible. This will avoid any unfortunate problems which might arise if the wrong tolerances are used. The equalization block is in aluminium, Aluminium-Bronze or Copper depending on the models; holes have been made on the inside to make it possible to fit various types of probes.

6.2.6 - Temperature sensors

The temperatures sensor used for regulating is a Pt100 and the temperature sensors used to protect the instrument is a thermocouple.. Both are inserted directly into the equalization block so as to supply a temperature value close to the real value in the block. There could, however, be some differences due to the tolerances of the sensors themselves.

6.2.7 - Safety thermostat

The calibrator is supplied with max. temperature safety thermostat (10) that disconnect the heating system. In case the thermostat intervenes:

- ◇ Waiting the cooling of calibrator: the temperature must decrease at least $60\pm 80^{\circ}\text{C}$ respect to maximum set point.
- ◇ Switch off the calibrator then switch on again a few second later on.
- ◇ If problem persist: disconnect the electrical cable to the oven and proceeding to repair of eventual faults (reference to paragraph 4); therefore switch on the oven. Consulting chapter 9 – typical faults – for any problems on the thermostat.

N.B.: the thermostat mounted on standard ovens has been calibrated in factory to intervene at 560 or 610°C $\pm 5^{\circ}\text{C}$ depending on the models.

6.3 - Start-up instructions

ATTENTION:

- The calibrator can only be used correctly if the user has a good knowledge of its basics.
- Before starting with the calibration following the instructions for the positioning of the equalising block (paragraph 5); carefully read paragraph 3 and 4.

To calibrate the probe it is possible to follow two ways: calibration with internal indicator (7), or calibration with external reference.

Calibration with the internal indicator (7):

Make reference to the temperature value of the display (7: fig 3).

It is opportune to refer the value to the test report to compensate the error of the display.

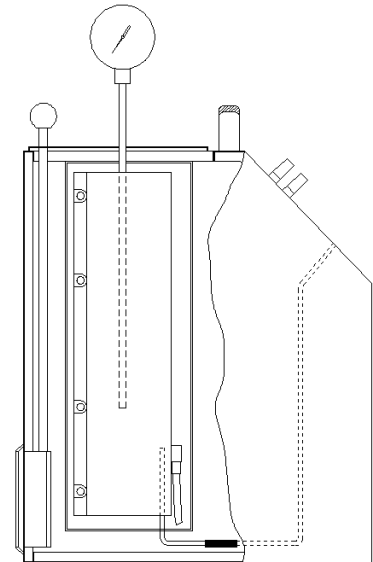

Fig.4

Calibration with external reference and reading on an external instrument:

Make reference to the temperature value of the external standard instrument inserted in the equalizer block and connected to an external instrument (Fig. 5). When possible: put the sensitive elements of the probes near and at the same dept (reference to fig.1-3-4).

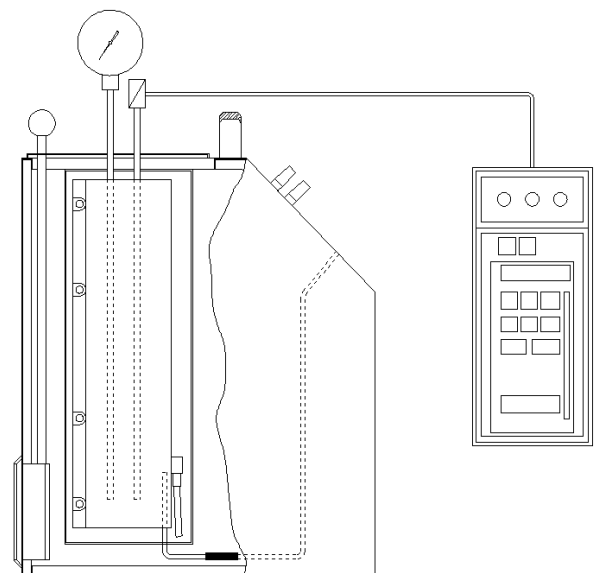

Fig.5

Before any calibration follow the general recommendation:

- Starting the calibration only at ambient temperature: thermal shock can break the sensitive element of the probe and cause harm to operator.
- To fit the equaliser block inside the oven: reference to paragraph 5.1.4.
- Put the probe to check into the equaliser block: reference to chapter 3 (fig 1-3).
- Push on the main switch (2) and waiting for the end of autotest procedure.
- Set the required temperature value on the set point following the instructions below:
 - ◇ Press the ▲ key to increment the set point value.
 - ◇ Press the ▼ key to decrement the set point value.
 - ◇ **Press the E key to confirm**
- Wait for the stabilisation of the oven before starting any calibration (symbol ÷ on the first line of the display).
- To working at different temperatures set the set point at the new value and wait for the stabilisation.
- When the set point is changed, the temperature read on the display and that measured in the block may not proceed at the same speed; this is because there are differences between the sensors used and the position of the same inside the block.
- The temperature indicated by display must not be considered as a reference temperature but only as a general indication of the temperature inside the block.
We suggest to insert a primary standard in the block; compare the measure with the values indicated by the standard.
Don't ever use the primary standard: it's possible to calibrate the instrument to more significant points, comparing the displayed temperature with the temperature of the primary standard.

AFTER TURNING ON AND SETTING THE FIRST SET-POINT WAIT AT LEAST 45 MINUTES BEFORE CONSIDERING STABLE AND UNIFORM THE TEMPERATURE OF THE THERMOSTATS INTRODUCED IN THE CALIBRATOR

ATTENTION:



- At the end of the calibration DO NOT remove the probe if it is still at high temperature. Always allow the calibrator to cool off with the probe still inserted in order to avoid thermal shock to the probe itself and harm to people or things.
- Before switch off the calibrator make sure that the temperature of the block is almost the same as ambient temperature.

Cooling:

To reduce the oven's temperature, change the set point and wait for the cooling.

REMEMBER TO SET THE AMBIENT TEMPERATURE AND LEAVE COOL THE CALIBRATOR BEFORE SWITCHING OFF

6.4 - Use of the functions

6.4.1 - Reading the external probes (only for model -2I)

It is possible to display one or two probes tied to the EXT and REF inputs.

The following probes can be connected:

1. THERMOCOUPLES TYPE J, K, R, S, N, E with automatic compensation of the terminal clamp temperature.
2. THERMAL RESISTANCE Pt 100 to 2, 3 or 4 wires.

- Connect the probe's wires to the clamps as it is indicated in the figures.
 - ◇ Thermocouple – connect the wires to the clamps 2-4 to make attention to the polarity; connect the clamps 1-3 as indicated. Reference to Fig. 6-A
 - ◇ Pt100 to 4 wires – connect the clamps 1-2-3-4 as indicated in Fig. 6-B
 - ◇ Pt100 to 3 wires – connect the wires to clamps 1-2-3; connect the clamps 3-4. Reference to Fig. 6-C
 - ◇ Pt100 to 2 wires – connect the wires to clamps 2-4; connect the clamps 1-2 & 3-4. In case of two wires connections remembers to us shortest wires possible. Refer to Fig. 6-D

- In order to read the external probe's temperature press the **F** key up to read SENSOR, select EXT or REF or EXT + REF then confirm with E key. Press the **▲** and **F** keys together to jump to the second level of the parameters, press **F** to read EXT SENSOR TYPE and REF SENSOR TYPE and press the **▼** and the **▲** keys to select the probe; the temperature will be displayed on the at the bottom of the display.
- Press the **▲** and **F** keys together to jump to the first level again , the temperature will be indicated on the bottom of the display.
- In order to read in the '°F' way, refer to the procedure explained in paragraph 10.1 till **Units°C/°F/K**; the conversion of the new scale will be carried out at once.

NOTE: The calibrator always thermally adjusts with the control probe situated inside the block.

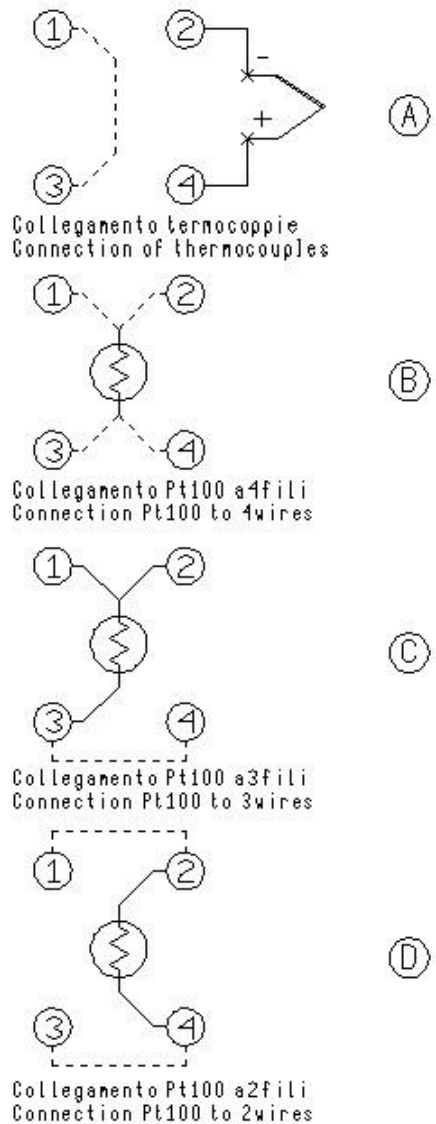

Fig. 6

MESSAGE OF ERROR OF THE EXTERNAL PROBES DISPLAY

The display in the case of connection or configuration errors indicates:

EST SENSOR FAIL : wrong connection or configuration of the EXT probe

REF SENSOR FAIL: wrong connection or configuration of the REF probe

SENSORS FAIL: wrong connection or configuration of the REF and EXT probes

6.4.2 - Switch test (SW. ON SW. OFF)

It is possible to control the intervention point of thermostats by the 'SWITCH TEST' function.

- Insert the sensor of the thermostat in the most suitable hole of the calibrator (refer to notes in paragraph 3).
- Connect the thermostat's electrical terminals to the bushes terminals (4).
- Turn the equipment on.
- Set the thermostat intervention temperature and check the release by the lighting of the indication light (7.3).
- The thermostat's release values are recorded. In order to display the recorded value, refer to the procedure explained in paragraph 10.1 till 'SW ON - SW OFF'.
- Press the ▲ and ▼ keys at the same time in order to reset the 'SW.ON - SW.OFF' values.
- Refer to paragraph 10.1 to set the ascent and descent ramps.

6.4.3 - Serial communication

On the front of the calibrator there is a 9 pole socket (5) connected to the thermo-regulator, which enables the calibrator to be completely controlled by a PC (reference to fig.7). The standard adopted RS-232 (contact the technical department for the communication number).

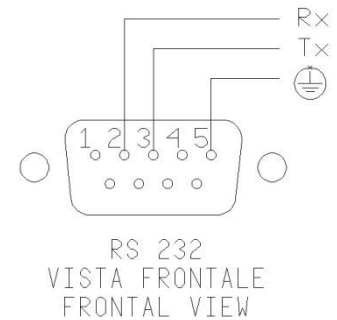

Fig.7



The external PC must conform to the IEC950 standard.

7 - MAINTENANCE INSTRUCTIONS

7.1 - Routine inspections instructions

- Check that the holes of the calibrator are cleaned, any liquid or oil inside the hole could make oxides or dirty during the use at high temperature.
- Check once a year the calibration date. Frequency of calibration is depending to the use of instrument; however we suggest to calibrate the instrument every year.
- To re-calibrate the instrument is necessary to have a standard temperature instrument, the software 'CALIBRA' and follow the instructions of the software or alternately follow the instructions of item 10.1.

8 - SEQUENCE OF MAINTENANCE

- Not applicable

9 - TYPICAL FAULTS



Before carrying out these operations the instrument must be disconnect from the electricity supply; the equaliser block must be at ambient temperature.

N°	FAULT DESCRIPTION	FAULTY COMPONENT OR FUNCTION	METHOD FOR REMOVAL
1	The calibrator does not work when the power cable is connected and the main switch is turned on.	<ul style="list-style-type: none"> - The fuse (3) is cut off. - The power cable is cut off. - The main switch is faulty. 	<ul style="list-style-type: none"> - Replace the fuses. - Replace the power cable with a similar one. - Replace the cup socket (1-3)
2	The fuses (3) are triggered when the power cable is connected and the main switch is turned on.	<ul style="list-style-type: none"> - The power card is faulty. 	<ul style="list-style-type: none"> - Replace the power card.
3	The control panel is working properly but the temperature does not increase.	<ul style="list-style-type: none"> - The thermoregulator (7) is faulty. - The static relay on the supply card (11) is faulty. - The heating element is cut off. - The safety thermostat (10) has been triggered. 	<ul style="list-style-type: none"> - Replace the supply card. - Replace the thermoregulator. - Replace the heating resistor - Reset the thermostat (ref. to 6.2.8)
4	The display indicates a different temperature from the one measured in the block.	<ul style="list-style-type: none"> - The probe (9) is faulty. - The thermo regulator (7) is faulty. 	<ul style="list-style-type: none"> - Replace the probe. - Replace the thermo regulator.
5	The temperature does not stop at the value of the point that has been set.	<ul style="list-style-type: none"> - The supply card (11) is faulty. 	<ul style="list-style-type: none"> - Replace the supply card.
6	The temperature does not decrease to the set value as quickly as it should.	<ul style="list-style-type: none"> - The thermo regulator (7) is faulty. - The cooling fan (6) is faulty. 	<ul style="list-style-type: none"> - Replace the thermo regulator. - Replace the fan
7	The display indicates "Overrange" or RTD failure	<ul style="list-style-type: none"> - The control probe (9) is cut off or is in short circuit. - The thermo regulator (7) is faulty. 	<ul style="list-style-type: none"> - Replace the thermocouple. - Replace the thermo regulator
8	The alarm lamp (6) light on	The safety thermostat has intervened	Wait until the temperature decrease than try to switch off and on again. If the fault persists to repair the equipment
9	The upper grid and/or the carpentry are very hot	<ul style="list-style-type: none"> - The fan (19) is blocked - The fan is faulty 	<ul style="list-style-type: none"> - Remove the obstruction - Replace the fan

10 - APPENDICES

10.1- Regulation Front Panel

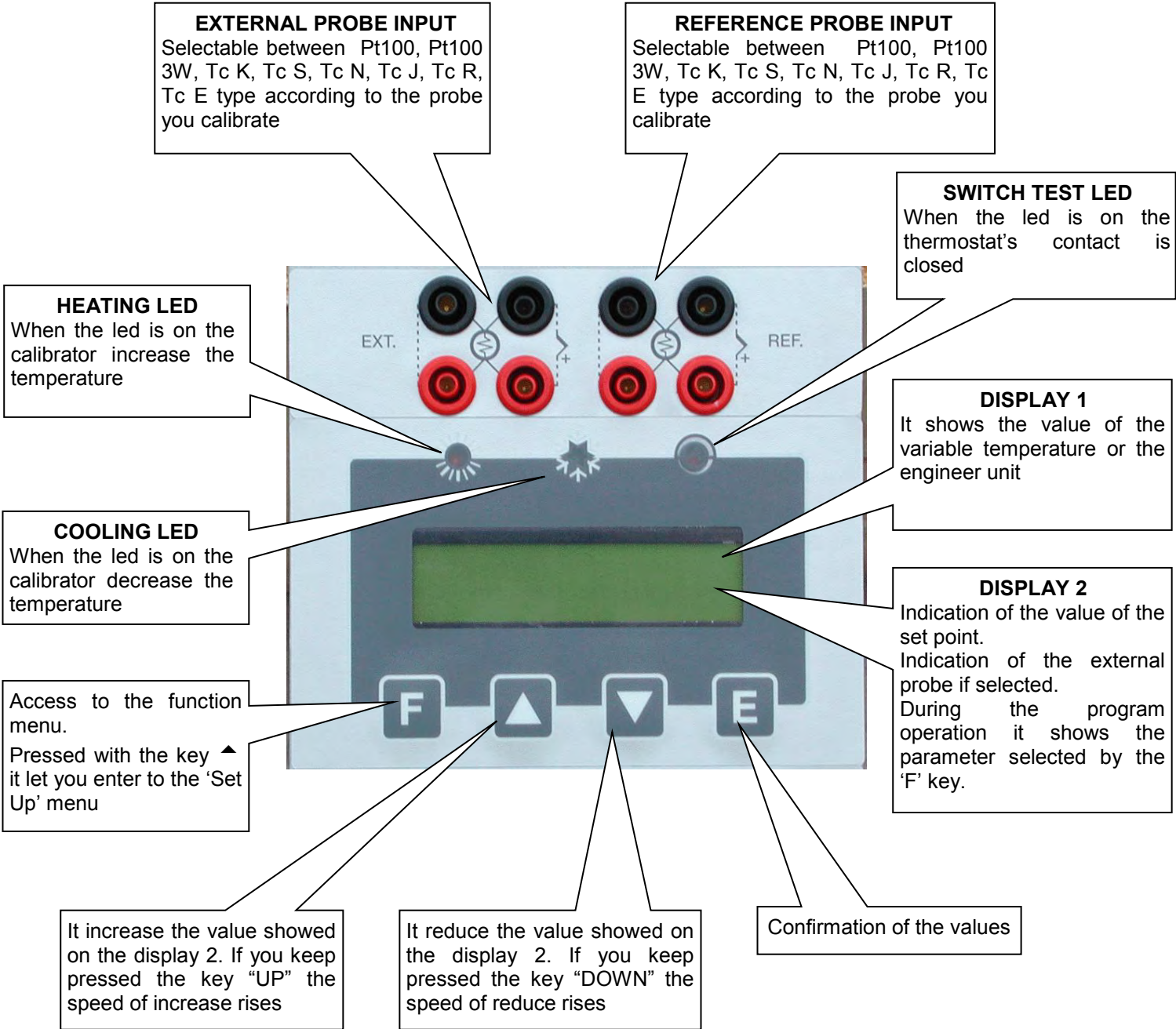

DESCRIPTION OF REGULATOR'S MENU

The calibrator has three menu levels(see image 10.2):

at the first level there are the functions for the continuous usage,

at the second level there are more specific functions for the regulation of the calibrator,

at the third level there are the typical functions for each calibrator and the calibration procedures.

1st MENU LEVEL

PRESS THE **F** KEY TO STEP THROUGH THE MENU

- **SP**

SET POINT: temperature set which the oven has to reach following technical specifications, press the **▲** or **▼** key to adjust the set point and press **E** key to accept new the new value.

- **SP2**

SET POINT2: temperature set which the oven reaches with the set gradient and the ongoing launched ramp procedure, press the **▲** or **▼** key to adjust the set point and press **E** key to accept new the new value.

- **GRAD**

GRADIENT: set point variation speed during the change from one temperature value to the SP2 value, press the **▲** or **▼** key to adjust the set point and press **E** key to accept new the new value.

The set gradient must be negative for descent ramps.

NOTE: gradient values to be set must be lower than the ones stated in the technical data, at point 2.2 (cooling grad. max.: -7°C/min.; heating grad. max. 18°C/min).

- **RAMP**

Ramp procedure enabling/disabling.

Select ON or OFF by the **▲** or **▼** key and press **E** key to accept; the oven will reach the set SP2 temperature with the set gradient, starting from the same temperature as the one with which the ramp has been confirmed. The starting temperature does not depend on the Set Point temperature.

If a negative ramp is set put the gradient is left positive and/or the SP2 is higher than the current temperature, the little over will not accept the ramp start and an alarm will begin running.

When the ramp is on, the display will show the word "**Ramp:.....**" followed by the Set Point value on the second line of the text. The Set Point value will reach the speed related to the set gradient.

When the block temperature reaches the SP2 set temperature, the oven will produce an alarm and the ramp procedure will be automatically set off; the SP2 value will be considered as the new set point value and the oven will be steadily set at that temperature.

During the ramp process, the derivative parameter will not be considered.

RAMP PROCEDURE EFFECTIVE EXAMPLE

Let's say that the set temperature is the ambient one and that it is necessary to reach 400°C with a gradient of 2°C/min.

- Press the **F** key and set **SP2** to 400°C using the **▲** or **▼** keys. Press the **E** key to accept.

- Press the **F** key and set **GRAD** to 1°C/min using the **▲** or **▼** keys. Press the **E** key to accept.

- Press the **F** key and set **RAMP** to **ON** using the **▲** or **▼** keys. Press the **E** key to accept.

After pressing the E key to confirm the ramp start, the oven temperature will ascend with the set slope.

Of course, there will be some oscillations at the beginning since the ramp slope will not be suitable but they will stop in a short time and then the oven temperature will follow the ramp's set point.

- **RIS. 0.1/0.01**

Display reading resolution; Press the **▲** or **▼** key to select 0,1 or 0,01 and press **E** key to accept.

- **SW. ON**

Switch on; displays the temperature at which the thermostat connected to the terminals "SWITCH TEST" is closed.

- **SW. OFF**
Switch off; it displays the temperature at which the thermostat connected to the terminals "SWITCH TEST" is open. The value is reset each time the power supply fails or by pressing the two "▲ ▼" keys at the same time. The value is updated every time that the contact closing is detected.
- **SENSOR (OFF/EXT/REF/EXT+REF)**
This parameter allows enabling the reading of sensors on the auxiliary inputs:
OFF no input is enable to read the sensors' value.
EXT the four terminals of the input EXT are enabled to read the sensor tied to them, whose value is indicated at the bottom of the Display.
REF the four terminals of the input REF are enabled to read the sensor tied to them, whose value is indicated at the bottom of the Display.
EXT+REF the eight terminals of inputs 1 and 2 are enabled to read the sensors tied to them, whose value is indicated at the bottom of the Display.

2nd MENU LEVEL

PRESS THE **F + ▲** KEYS AT THE SAME TIME TO ACCES THE SECONDARY MENU.

PRESS THE **F** KEY TO STEP THROUGH THE MENU.

PRESS THE "**F + ▲**" KEYS AT THE SAME TIME OR WAIT FOR ABOUT 20 SECONDS TO COME BACK THE PRIMARY MENU

- **P.B.**
Value of the Proportional Band expressed in percentage of the value of the end of the scale. Proportional band means the length of time in the measure field within which there is the variation of the regulation probe exit alarm and therefore the adjustment of the heating element power.
- **T.I.**
Integral Time value expressed in seconds. The integrating action cancel the error between the chosen set point and the temperature reached only by the proportional action. Integral time means the length of time necessary to the integrative action to double up the proportional action
- **T.D.**
Derivative Time expressed in seconds. When there is a step variation of temperatures, the derivative action induces an greater initial adjustment, so that the oven will have a greater power than it usual has due to the proportional and integral action only. Since the error keeps existing, the derivative action reduces the impact giving the integrative action the task of reducing the error.
- **EXT SENSOR TYPE: J, R, S, N, K, E, Pt100, Pt100 3wires**
This parameter allows selecting the kind of sensor read by the display and connected to the four Ext. terminals.(item 6.4.1)
- **Units °C/°F/K**
This parameter allows selecting the temperature measuring unit. By selecting "**°C**" all temperatures will be expressed in Celsius degrees; by selecting "**°F**" all temperatures will be expressed in Fahrenheit degrees.
- **Def. Par. ON/OFF**
Default Parameter; this function allows choosing to set the thermoregulator with the P.B., T.I., T.D. parameters either as a default or as a customisable adjustment. By selecting the "**OFF**" parameter and confirming by the "**E**" key it is possible to modify the adjustment parameters, which will keep operational even if the calibrator is turned off. By selecting the "**ON**" key (followed by the confirmation by pressing the "**E**" key) the adjustment values will be set on the default ones recorded by the manufacturer, and therefore not allowing to be changed. By turning the calibrator off the parameter will set on OFF but the default parameters will be kept recorded.
- **REF SENSOR TYPE: J, R, S, N, K, E, Pt100, Pt100 3wires**
This parameter allows selecting the kind of sensor read on the display and connected to the four REF. Sensor terminals.(item 6.4.1)

- **KEY**

This is the key to step the third menu level. Press \blacktriangle or \blacktriangledown key to set the number recorded in the "**ACCESS KEY**" parameters at the third menu level, and press "F" + \blacktriangle keys at the same time (*it is not necessary to confirm the choice by pressing the E key*) to step to the third menu level. The acceptable values are from 1 to 99: **the default set value is 2. If you lost the access key remember that it is possible to have the number by reading the register 13 (item 10.3)**

3rd MENU LEVEL

MENU THAT CAN BE SELECTED BY PRESSING THE "F + \blacktriangle " KEYS AT THE SAME TIME WHEN THE **KEY** PARAMETER IS REACHED AT THE SECOND LEVEL AND WHEN THE SET VALUE CORRESPONDS TO THE RECORDED ONE.

PRESS THE **F** KEY TO STEP THROUGH THE MENU.

PRESS THE "F + \blacktriangle " KEYS AT THE SAME TIME OR WAIT FOR ABOUT 20 SECONDS TO COME BACK THE PRIMARY MENU

- **ACCESS KEY**

Access key; numerical value from 1 to 99 that enables passing to the third parameter level. **The default value is 2**

- **BAUD RATE**

Data transmission speed from the computer. Values are from 2400 to 19200 (**default value is 9600**).

- **ADDRESS**

Communication address. The value of this parameter is necessary to communicate from the computer to many instruments. The admitted values are from 1 to 32 and once the value is set by using the \blacktriangle or \blacktriangledown keys it is necessary to confirm the choice by the **E** key

- **S/N**

Equipment serial number. It is set by the manufacturer and cannot be changed by the user.

- **Board S/N**

Serial number of the board. It is set by the manufacturer and cannot be changed by the user.

- **MAX. SET.**

Maximum value of the Set Point. It is set by the manufacturer and cannot be changed by the user.

- **MIN. SET.**

Minimum value of the Set Point. It is set by the manufacturer and cannot be changed by the user.

- **WAIT**

initial waiting procedure. If the value "0" is set, when it is started up, the calibrator immediately run to the last set point value chosen after turning off. If the value "1" is set, when it is started up, the calibrator goes on the waiting position and the **SP** flash. It is necessary to press any key in order to move it from the waiting position and to choose the desired Set Point value. It is possible to set the WAIT value only by the serial communication.

- **REV. SOFTWARE**

Internal software's release number.

- **SENSOR TYPE**

It indicates the type of the internal probe.

- **STAB:**

It indicates the swinging value of the temperature, which has been set to see on the Display the symbol of the oven \div steadiness. The symbol light on when the temperature is stable for over 6 minutes.

- **Cal_chnl:**
Chooses the channel to be calibrated. It can assume three values: **INT**, **EXT**, **REF**. Press the ▲ or ▼ key to select **INT**, **EXT** or **REF** and press **E** key to accept

- **P1:**
First Calibration point. Press the ▲ or ▼ key to set the value read with the standard thermometer and press **E** key to accept

- **P2:**
Second Calibration point. Press the ▲ or ▼ key to set the value read with the standard thermometer and press **E** key to accept.

- **CAL: INT (Y/N):**
This writing can have three different configurations.

CAL: INT (Y/N)	if Cal_chnl is set on INT
CAL: EXT (Y/N)	if Cal_chnl is set on EXT
CAL: REF (Y/N)	if Cal_chnl is set on REF

Press the ▲ or ▼ key to set **Yes** or **Not** and press **E** key to accept.

EXAMPLE OF RE-CALIBRATION

The appliance can have a complete or partial re-calibration yearly or when chosen by the user. Calibration can be carried out using CALIBRA ED200 software or directly on the keyboard of the appliance. The calibration of the INTERNAL probe is done by adjusting the internal probe at two points of the range using a standard thermometer. The calibration of the EXTERNAL and the REFERENCE inputs is done by adjusting the inputs of the controller at two points of the range using a mV/ohm standard generator.
The calibration is possible only by setting the temperature in °C.

CALIBRATION OF THE INTERNAL PROBE

The purpose of re-calibration is to correct the error between the temperature indicated and the value of a standard thermometer.

To calibrate the internal probe it is necessary to have a standard thermometer with precision greater than that of the appliance and then to follow the instructions:

1. Insert the standard thermometer probe in the temperature bath or in the most suitable hole of the calibrator.
2. Choose two calibration points depending on the appliance range or the field where one wishes to carry out calibration. For example the points 0 and 120°C are recommended for the QUARTZ.
3. Set the first calibration point and wait for the appliance to be stable (see symbol ⇄)
4. Enter the third menu level (see instructions) and select Cal_chnl= INT. Press E to confirm.
5. Press F to select P1, press the ▲ or ▼ key to set the value read with the standard thermometer and press **E** Key to accept. Confirmation is indicated by the symbol * which appears on the display after about 5 seconds.
6. Return to the first menu level and set the second set point. Then wait for the appliance to be stable (see symbol ⇄).
7. Enter the third menu level (see instructions) and select P2, press the ▲ or ▼ key to set the value read with the standard thermometer and press **E** Key to accept. Confirmation is indicated by the symbol * which appears on the display after about 5 seconds.
8. Select **CAL: INT** set **Yes** and confirm by pressing **E** key . Calibration begins. The procedure takes a few seconds, at the end of which there is a Beep.

CALIBRATION OF THE **EXT + REF** INPUTS with a signal calibrator

The purpose of the re-calibration is to correct the EXT and REF inputs error together.

To calibrate the two inputs, it is necessary to have a Pt100 calibrator and/or a thermocouples calibrator depending on what is to be calibrated.

Calibration of the EXT input automatically reproduces the same calibration on the REF input:

1. On the second menu level, select the type of EXT input to calibrate (Pt100, Tc K, Tc J, Tc N, TcR, Tc S, Tc E) following the instructions in the manual. Press E key to confirm.
2. Enter the third menu level (see instructions) and press the ▲ or ▼ key to set Cal_chnl= **EXT**. Press E to accept.
3. Choose two calibration points depending on the appliance range or the field where one wishes to carry out calibration. (For example 0 and 450°C for PT100, 200 and 800°C for the thermocouples).
4. Connect the signal generator to the EXT input, generating the first calibration value. See the instructions for the connection.
5. Select P1 and press the ▲ or ▼ key to set the first value (for example 0°C). Press E Key to confirm. Confirmation is indicated by the symbol * which appears on the display after about 5 seconds.
6. Generate the second calibration value with the signal generator. See the instructions for the connections.
7. Select P2 and press the ▲ or ▼ key to set the second value (for example 450°C). Press E Key to confirm. Confirmation is indicated by the symbol * which appears on the display after about 5 seconds.
8. Select **CAL: EXT** Set **Yes** and confirm pressing E Key. The procedure takes a few seconds. At the end there is a Beep.

CALIBRATION OF THE **REF** INPUT with a with probe connected

This operation adapts the value indicated by the REF input to the value indicated by the probe connected to it, compensating its errors.

To carry out the calibration it is necessary to connect the probe to the REF terminals and to have a standard thermometer

1. Connect the probe to the **REF** input following the instructions in the manual.
2. Insert the probe in the suitable hole in the appliance.
3. Insert the standard thermometer in the appliance.
4. Set the first calibration point and wait for the appliance to be stable (see symbol ÷)
5. Enter the third menu level (see instructions) and select Cal_chnl= **REF**. Press E key to accept.
6. Select P1 and press the ▲ or ▼ key to set the value read with the standard thermometer. Press E key to accept. Confirmation is indicated by the symbol * which appears on the display after about 5 seconds.
7. Return to the first menu level and set the second set point. Then wait for the appliance to be stable (see symbol ÷).
8. Enter the third menu level (see instructions), select P2 and press the ▲ or ▼ key to set the value read with the standard thermometer. Press E Key to accept. Confirmation is indicated by the symbol * which appears on the display after about 5 seconds.

Select **CAL: REF** Set **Yes** and confirm pressing E Key. Calibration begins. The procedure takes a few seconds. At the end there is a Beep.

10.2 - Microprocessor regulator: control description

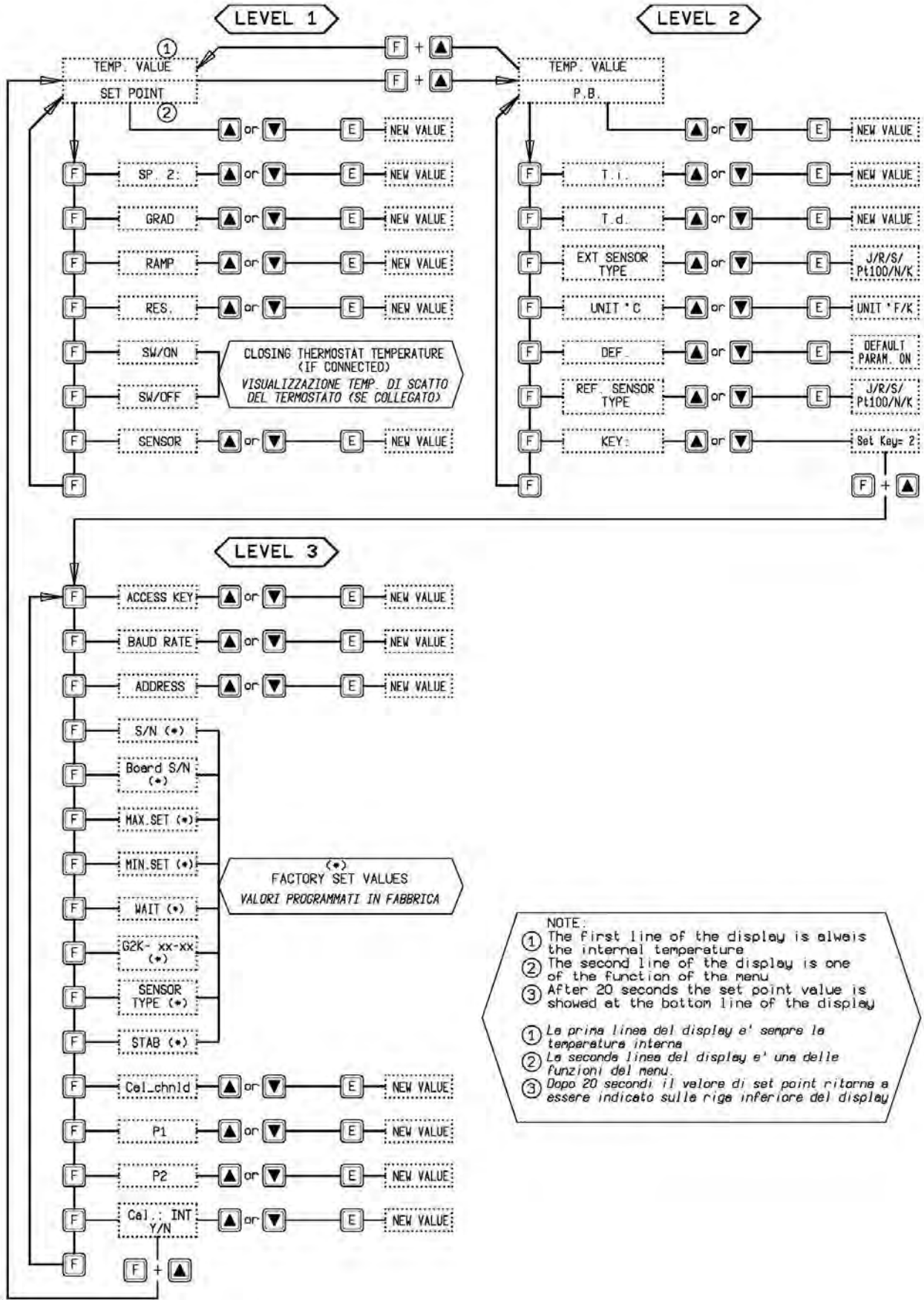

10.3 - Communication Protocol Rs232/C

General characteristics:

Baud Rate: 9600 Parity: No
N. Bit: 8 Bit of stop: 1

The communication runs in half duplex way which means that is transmission and reception could not be contemporaneously present.

The regulator replies only after receiving command; it never replies itself.

The command and reply are ASCII character string, as detailed forward. The communication program will be able to convert ASCII to decimal to extract numeric values. The default address is 1.

Baud rate: 2400, 4800, 9600 e 19200 baud, the Default value is 9600; the other parameters are standard.

VARIABLES AVAILABLE IN READING	
0	Set point
1	Ramp ON/OFF
2	Set point 2
3	Gradient
4	Resolution
5	Prop. Band
6	Integral time
7	Derivative time
8*	Sensor input selection
9	Title
10***	Units (°C/°F/K)
13	Access key
14	Baud rate
15	Address
16	Serial number
18	Mx. set point
19	Min. set point
21	Wait ON/OFF
22	Switch on temperature
23	Switch off temperature
24	Version
25**	Ext. Sensor type
26**	Ref. Sensor type
28	Stability range
29	Symbol of steadiness
100	Temperature
105	Ext. temperature
106	Ref. temperature

VARIABLES AVAILABLE IN WRITING	
0	Set point
1	Ramp ON/OFF
2	Set point 2
3	Gradient
4	Resolution
5	Prop. band
6	Integral time
7	Derivative time
8*	Sensor input selection
9	Title
10***	Units (°C/°F/K)
13	Access key
15	Address
25**	Ext. Sensor type
26**	Ref. Sensor. type

* 8* Sensor input selection	
1	Correspond to the INTERNAL probe
2	Correspond to the INTERNA+EXT probe
3	Correspond to the INTERNA+REF probe
4	Correspond to the INTERNA+EXT +REF probe

** 25/26** Ext. Sensor type/ Ref. Sensor type	
0	Correspond to the Pt 100 4 wires
1	Correspond to the N thermocouple
2	Correspond to the K thermocouple
3	Correspond to the J thermocouple
4	Correspond to the R thermocouple
5	Correspond to the S thermocouple
6	Correspond to the Pt100 3 wires
7	Correspond to the E thermocouple

*** 10***Units (°C/°F)	
0	Correspond to the °C
1	Correspond to the °F
2	Correspond to Kelvin temperature

* the variable 8 is available only for the models **LR-Cal** SOLAR-2I-X; the value of the variable corresponds to the table.

** the variable 25/26 is available only for the models **LR-Cal** SOLAR-2I-X; the value of the variable corresponds to the table.

*** the value of the variable 10 corresponds to the table.

Each commands string are ASCII character succession.

First is \$ character; the next must indicate the instrument address (default 1) and than is the command (4 characters).

Possibility:

RVAR (data reading)
WVAR (data writing)

The ultimate part of string is depending of a type command. The character (cr) concludes the sequence

DATA READING:

Example 1) reading of the Set Point (0 variable):

the command string is: **\$1RVAR0_<cr>**

Each characters means:

\$	beginning of message
1	instrument address
RVAR	reading command
0	number of the variable to read (see the table of the "VARIABLES" on the previous page)
_	space
<cr>	end of message

the response string is: ***1_110,0** (110,0 is only for example)

The character <cr> concludes the message.

Command to read the temperature of an external probe (index 25):

Example 2) reading of the EXT sensor (105 variable):

the command string is: **\$1RVAR105_<cr>**

the response string is: ***1_123,4** (123,4 is only for example)

The character <cr> concludes the message.

The response does not include the measure unity, to read the unity read the variable 10:

the command string is: **\$1RVAR10_<cr>**

the response string is: ***1_0 for °C**

the response string is: ***1_1 for °F**

DATA WRITING:**FLOAT VARIABLES**

For writing you use the command WVAR.

Examples 1) writing of the Set point to 132,5°C

If the unity of measure of the temperature is already °C it is enough to write the SET POINT (see the table of the "VARIABLES" on the previous pages).

the command string is: **\$1WVAR0_132,4<cr>**

Each characters means:

\$	beginning of message
1	instrument address
WVAR	writing command
0	number of the variable to read (see the table of the "VARIABLES" on the previous pages)
_	space
132,4	numerical value of a data with the character . to separate the decimal part of the number
<cr>	end of message

At reception of the command, the answer of the instrument is:

*1<cr>

This string shows the recognition of the command.

If the unity of measure of the temperature is not °C You should write first the variable 10 UNITS to 0(see the table of the "VARIABLES" on the previous pages).

INTEGER VARIABLES

We have just shown the procedure for the writing of a float data.

The variables 1, 4, 8, 10, 25, 26 have two or more states (for example, the resolution by tenth or hundredth of °C) and to activate them it is necessary to assign to the variable number the number corresponding to that one which should be set, according to the table indicated below:

1	Ramp	ON = 1	OFF = 0			
4	Resolution	0.1°C = 0	0.01°C = 1			
8	Sensor input selection	INT = 1	INT+EXT = 2	INT+REF = 3	INT+EXT+REF = 4	
10	Units	°C = 0	°F = 1	K=2		
25	Ext. Sensor type	0 = Pt 100	1 = Tc N	2 = Tc K	3 = Tc J	4 = Tc R
		5 = Tc S	6 = Pt 100 3 wires	7 = Tc E		
26	Ref. Sensor type	as for the variable 25				

Example 1: the variable 1 corresponds to the activation of the ramp. If you want to set it to ON in order to activate the ramp, you should assign the value 0, otherwise the value 1.

the command string is: **\$1WVAR1_0<cr>**

Example 2: the variable 8 corresponds to the activation of the sensor reading which can be connected to the bushes of the external inputs. If you want to read the thermocouple K connected to the Ref. input, you should set the variable 26 to the number corresponding to the type of sensor which you want to read (2 for the thermocouple K) and then set the variable 8 to 3.

the command strings are: **\$1WVAR26_2<cr>** **\$1WVAR8_3<cr>**

Do likewise for the other variables.

10.4 - List of spare parts

(Numerical references related to the enclosed drawings)

1-3	FILTERD INPUT SWITCH	3SCH283106
3	FUSES	5X20 10A
3.1	VARISTOR - DIAM. 20	3MRC20D391
5	RS-232 INPUT	3ICIDSUB09PS
6	LIGHT	3RSC3693267
7	TERMOREGULATOR + DISPLAY	4ED20048
8	PT100	3DC065
10	SAFETY THERMOSTAT + TCK	4ED10085-6V + 3DC2417
11	CONTACTOR	3ABBB63010220
12	SUPPLY CARD***	4020-99-DS-F
13	HEATING RESISTOR	ø80xh.300 1600W 230V LC400 3RCAFZSK466A005
15	AUXILIARY INPUT PROBE(OPTIONAL)	4ED20011
17	INSERT EXTRACTOR	2D1049
18	POWER CABLE	3NEP5942AW
19	FAN 230V-50/60Hz	3PPS-3956
20	STATIC RELAY	4GFRGQ2548D11
21	THERMOSTAT	3RSC339724

*** included only in the serial number lower than L210 12

10.5- Declaration of conformity and check report

The declaration of conformity CE is at the end of the English manual, the test report is included with the calibrator

10.6 - Drawing and wiring diagram

The drawings are at the end of the English manual.

"Declaration of conformity"

DRUCK & TEMPERATUR Leitenberger GmbH
Factory: Bahnhofstr. 33, 72138 Kirchentellinsfurt, Germany

Declares that the: **THERMOSTATIC CALIBRATOR PULSAR-80-CU**
is conforms with the requirements of the following European directive:

- Low voltage directive 2006/95/CE
- EMC directive 2004/108/CE

and that it has been designed in accordance with the following harmonised regulation:

- EN 61000-6-3 emission.
- EN 61000-6-2 immunity.
- EN 61010-1/61010-2-010 safety requirements for electrical equipment

The conformity with the above-mentioned requirements is certified by affixing the CE Mark on the product.

DRUCK & TEMPERATUR Leitenberger GmbH



i.V. Gerd Broglie

