

RMD680 8/16-channel universal input transmitter and multiplexer with serial output RS-485

- Process inputs: 0/4..20mA, -20..+20mA, 0..10V, -10..+10V
- mV input range: -100..+100mV
- Thermocouples: B,C,D,E,G,J,K,L,N,R,S,T
- RTD sensors: Pt100, Pt1000, Ni, Cu, KTY83
- Resistance input range: 0..40000 ohm
- 1 analog output 0/4..20 mA or 0..10V, channel selection with digital inputs or min/max value
- 2 alarm relays, with common alarms
- Display on front panel
- Programming with front panel keys or with serial interface RS-485
- Modbus RTU and Nokeval SCL serial protocols
- Power supply 24 VDC, galvanically isolated from inputs



Multichannel transmitter RMD680 has been designed for applications where lots of inputs have to be measured and transferred economically either to PC or PLC. Transmitter has 16 input channels, which can be programmed individually for different sensors. Measurement rate is 12 channels per second. Measurements can be read either by serial interface RS-485 using Modbus RTU or Nokeval SCL protocol or with one analog output. Up to 32 devices can be connected to the same serial bus without repeaters. It takes 30ms to read all channels from one device, thus 512 channels can be read in less than second. When analog output is used, output channel is selected with a 4-bit digital input. Transmitter has also 4-bit digital input for en-

abling its analog output thus total channel count can be increased to a maximum of 256 channels by connecting mA outputs of several devices in parallel. This way all channels from one device can be read in less than one second. Every channel can be configured totally individually. Channel inputs are differential thus channels don't affect on each other. Transmitter has two alarm relays, that can work as common alarms: if any channel passes alarm limit, the relay activates. Device can be configured either with front panel keys or with serial interface using Mekuwin configuration software. Transmitter is compatible with WinX and PromoLog data-acquisition software and any third party software with Modbus communication.

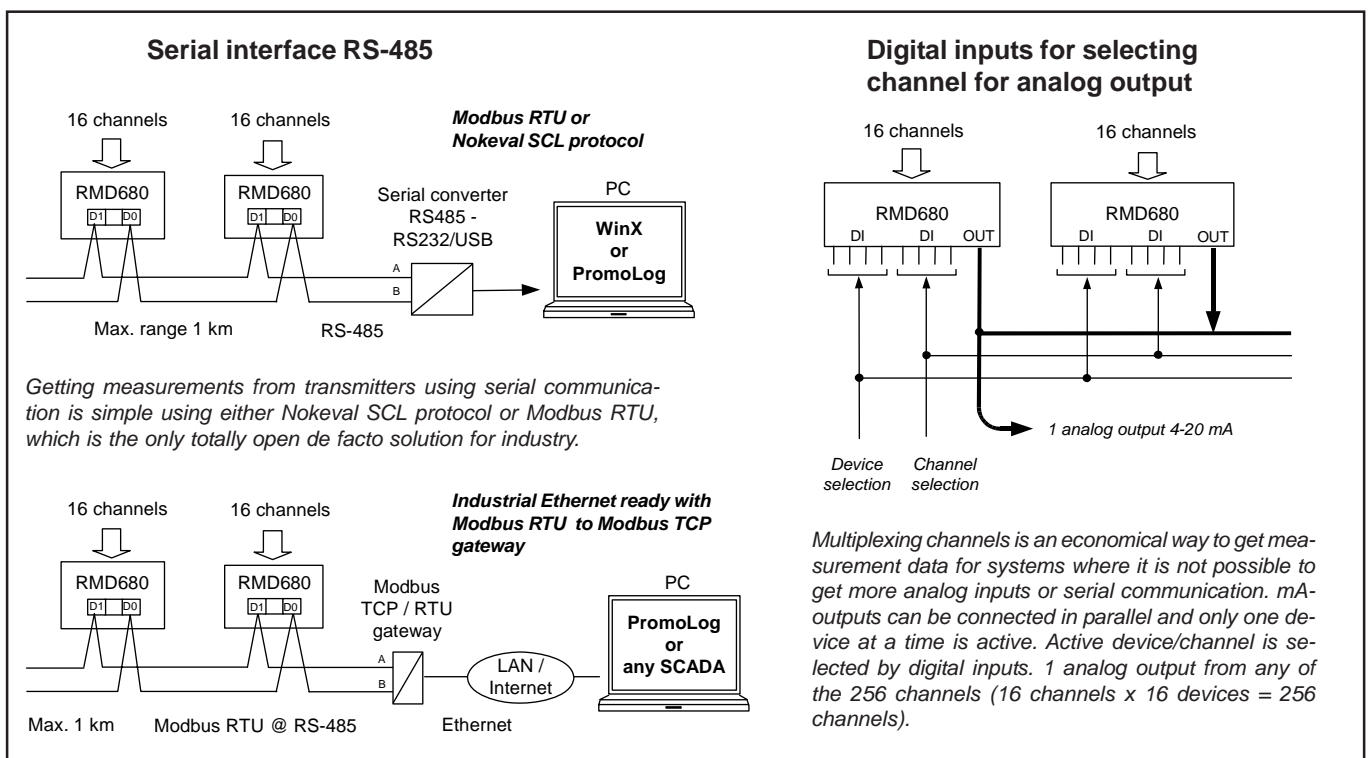

Technical specification:

RTD sensors:

Sensors	Pt100, Pt1000 or Ptxxx (xxx = selectable)
Range	-200..+700°C
Accuracy (Pt100)	0.05% of reading + 0.25°C
Temperature coefficient	0.02°C / °C
Sensor connection	3-wire
Measurement current	0,25 mA, multiplexed
Sensor error correction	Adjustable for each channel

Sensors	Ni100 or Ni100 (xx = selectable)
Range	-60..+180°C
Accuracy	0.05% of reading + 0.25°C
Sensors	Cu10 or Cuxx (xx = selectable)
Range	-200..+260°C
Sensor	KTY83
Range	-55..+175°C

Thermocouples:

Sensor	Range	Linearization error
B	400..1800°C	±0.3°C
C (W5)	0..2300°C	±0.5°C
D (W3)	400..1800°C	±1.0°C
E	-100..900°C	±0.2°C
G (W)	1000..2300°C	±2.0°C
J	-160..950°C	±1.0°C
K	-150..1370°C	±0.5°C
L	-150..900°C	±0.5°C
N	0..1300°C	±0.1°C
R	0..1700°C	±0.5°C
S	0..1700°C	±0.5°C
T	-200..400°C	±1.0°C

Accuracy 0.05% of reading + 1°C + linearization error
 Line resistance effect < 1 kΩ, no effect
 Cold junction error 0.02°C/°C

Process inputs (freely scalable):

mA-inputs	0/4..20mA, ±20mA
Accuracy	0.008mA
Input resistance	about 70Ω

V-inputs	±1V, 2.5V(-1..+2.5V), ±10V
Accuracy	0.05% of reading + 0.01V
Input resistance	>500kΩ (1, 2.5V), >1 MΩ (10V)

Other inputs (freely scalable):

mV-inputs	±55, ±100mV
Accuracy	0,1% of reading + 0.01mV
Input resistance	>1 MΩ

Resistance inputs	0..400 Ω / 4 kΩ / 40 kΩ
Accuracy	1% of FS

Serial interface:

Connection	RS-485 (2-wire)
Protocols	Modbus RTU, Nokeval SCL and Meku
Baud rate	1200, 2400, 4800, 9600, 19200, 38400, 57600
Bits	SCL:8N1 Modbus: 8E1, 8O1, 8N2
Reaction time	SCL: < 40ms Modbus: < 4ms
16 channel read	SCL: 110ms Modbus: 30ms @ 38400
Maximum range	1000 m

Alarms:

2 alarm relays, max 250VAC, 2A resistive
 General alarms selectable

Digital inputs:

Output- and/or display channel selection
 4 bits for device address, 4 bits for channel
 0/4-20mA and 0-10V (freely scalable)
 Accuracy 0.05%, resolution 12 bits
 mA output load 600Ω
 Reaction time <40 ms after channel change

Analog output:

Accuracy 0.05%, resolution 12 bits
 mA output load 600Ω
 Reaction time <40 ms after channel change

Programming:

With serial interface RS-485 (PC) Meku protocol or directly with front panel keys

General information:

Channel count 16 input channels, differential input
 Digital display 5 digit red LED display, height 7.5 mm and 2 digit channel display
 Galvanic isolation Input / Output 1 kV / 1 min
 Measurement rate 12 (25 at maximum rate) channels / s
 AD resolution 16 bits (±32767)
 Differential input mV in: -0.15..+0.95V V,mA in: -1..3V

EMC immunity EN 61326
 EMC emissions EN 61326 class B

Operating temperature -10..60 °C
 Storage temperature -30..+70 °C
 Humidity 0..95 % non condensing
 Enclosure material Plastic Lexan 940 / Noryl VO 1550
 Installation DIN-rail, 35 mm
 Terminals connectors Detachable, 1.5 mm²
 Weight 320g
 Power supply 24 VDC ±15 %, <100 mA

How to order: RMD680-16-24V

Model _____
 8 or 16 channels _____

Options:

Configuration software MekuWin (PC software)
 USB-RS485 converter DCS770

Connections and dimensions:

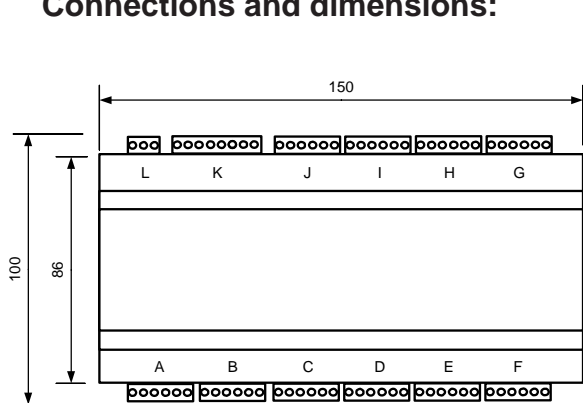

Every 6 pin connector has two channels. Connection diagram shows only first and last channel pairs.

