

SHM40 Structural Humidity Measurement Kit

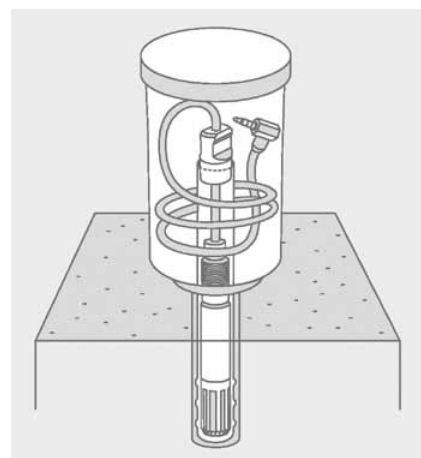

A borehole in concrete and a measurement probe HMP40S inserted in it.



Snapping a connector to the indicator HM40 to read the measurement results.

Vaisala HUMICAP® Structural Humidity Measurement Kit SHM40 offers an easy and reliable solution for humidity measurements in concrete and other structures.

Concrete dries unevenly and is usually drier on the surface, consequently it is important to measure beneath the surface conditions. The borehole method provides information about the humidity profile under the surface. In this method, a humidity probe is left in the borehole until the humidity in the hole has reached an equilibrium state and the stabilized values can be read.

SHM40 Is All You Need for Borehole Humidity Measurement

The Vaisala HUMICAP® Structural Humidity Measurement Kit SHM40 is an ideal solution for the borehole method. The starter kit is comprised of an HMP40S probe, HM40 indicator and accessories for the borehole method in a weather-proof case, optimized for use in harsh and humid construction sites. Additional accessories for the SHM40 can be used to prepare a moisture measurement hole in fresh concrete. Pre-formed holes eliminate the need for drilling and the risk of damaging

heating elements or tubing embedded in the concrete.

Easy Measurement with Multiple HMP40S Probes and Quick Connectors

HMP40S measurement probes are interchangeable. The probes connect easily to the HM40 indicator with a snap-on connector enabling convenient use of multiple probes with one indicator. The measurement data can be displayed in numeric, statistic or graph views.

Features or Benefits

- Easy to use
- Truly interchangeable measurement probes
- Durable
- Accurate measurement data in numeric, statistic or graph views
- Conforms to ASTM standard F2170
- IP65 classified measurement probe and case

Standard Contents of SHM40

- HM40 indicator with adapter
- 1 piece HMP40S RH&T probe with a cable
- 12 pcs plastic tubes (19266HM)
- 12 pcs rubber plugs (233976)
- 3 pcs protective covers with lid (19268HM)
- NIST traceable certificate
- Weather-proof carrying case with a shoulder strap

Technical Data

HMP40S Probe

Relative Humidity

Measurement range	0 ... 100 %RH
Accuracy (incl. non-linearity, hysteresis, and repeatability):	
temperature range	0 °C ... +40 °C
0 ... 90 %RH	± 1.7 %RH
90 ... 100 %RH	± 2.5 %RH
temperature range	-40 °C ... 0 °C and +40 °C ... +80 °C
0 ... 90 %RH	± 3.0 %RH
90 ... 100 %RH	± 4.0 %RH
Factory calibration uncertainty at +20°C (68°F)	± 1.5 %RH
Humidity sensor	HUMICAP® 180R
Stability	± 2 %RH over 2 years

Temperature

Measurement range	-40 °C ... +80 °C
Accuracy over temperature range:	
0 ... +40 °C	± 0.2 °C
-40 ... 0 °C, +40 ... +80 °C	± 0.4 °C
Temperature Sensor	Pt1000 RTD 1/3 Class B IEC 751

General

Operating temperature range for probe	-40 °C ... +80 °C
Probe weight with standard cable	31 g
Probe housing material	stainless steel
Probe filter and sensor protection	membrane filter with chrome coated ABS plastic
Cable material	Wire PVC / jacket PU
Cable connector	TRRS male 3.5 mm
Probe housing classification	IP65
Borehole diameter needed	16 mm
Measurement depth with standard accessories	min. 30 mm, max. 90 mm

HM40 Indicator

Operation temperature range for indicator	-10 ... +60 °C
Storage temperature range	-30 ... +70 °C
Weight	
Indicator with adapter	240 g
SHM40 case with standard content	3.7 kg
Indicator materials	PC/ABS blend, acrylic display lens
Indicator adapter materials	Nickel plated brass and plastic overmolding
Indicator housing classification	IP54
Mechanical drop endurance	1.0 m without the probe

Power-up time	< 3 s
Alkaline batteries	2 x AA sized, 1.5V (LR6)
Operation time (Alkaline batteries)	typical 100 hours (without backlight)
Calculated variables	Td, Tw, a, x, h
Menu languages	English, German, French, Finnish, Spanish, Swedish, Chinese (simplified), Russian, Japanese
Display	LCD (140 x 160 pixels)
Electromagnetic compatibility (EMC)	European Union directive EN61326-1 for portable equipment

Accessories and Spare Parts

HM40 indicator with adapter and cable probe	HM40S
RH&T probe with cable	HMP40S
HM40 indicator with adapter	HM40SINDI
Quick connection adapter	HM40SADAPTER
Cable for RH&T probe	HMP40SCABLE
Long cable (2.7 m) for RH&T probe	HMP40SCABLE2
Plastic tube set (12 pcs)	19266HM
Rubber plugs (12 pcs)	233976
Protective cover with lid (3 pcs)	19268HM
Weather-proof carrying case with SHM40 filling	233815
USB recharger for HM40 indicator batteries	229249SP
Plastic grid with membrane filter for HMP40S probe	DRW010525
ACCESSORIES FOR WET CONCRETE	
Plastic flange set (12 pcs)	26529HM
Long rubber plug for wet concrete (12 pcs)	26530HM

Dimensions

Dimensions in mm

