

SPH10/20 Static Pressure Heads for Minimizing Wind Induced Error

Wind induced effects are one of the main sources of error when measuring barometric pressure. Variations due to strong and gusty wind can be overcome by using a static pressure head to 'filter out' the effect of dynamic pressure.

The Vaisala Static Pressure Head Series SPH10/20 are designed to minimize the errors caused by wind. The wind tunnel tested structure is both horizontally and vertically symmetrical. This design ensures reliable barometric pressure measurements in all weather.

Ideal for outdoor installations

Vaisala's static pressure heads are available in two models: the Vaisala Static Pressure Head SPH10 is a basic version, and the Vaisala Static Pressure Head SPH20 is a heated version for reliable operation in snowy and icy conditions. The warmed SPH20 contains a thermostat that switches on the warming power at temperatures, where the risk of icing may occur.

Composed of ultraviolet stabilized PC plastics and offshore aluminium, the

SPH10/20 static pressure heads are durable and weather resistant.

The SPH10/20 protects against rain and condensed water, thus preventing capillary condensation of a water column in the pressure channel which results in pressure error. The drain holes in the lower plate allow rain and water to flow out. The static pressure heads have internal netting which prevents insects and debris from blocking the pressure channel.

Carefree maintenance

The SPH10/20 static pressure heads are easy to install and disassemble, service and clean – even at the installation site. Vaisala BAROCAP® Digital Barometer PTB210 can be installed directly on top of the SPH10/20 static pressure heads. Other barometers can be connected to the heads with pressure tubing. SPH10 and SPH20 are a perfect pair for all Vaisala barometers. They ensure an accurate and reliable measurement in all weather conditions.



The SPH10/20 is easy to install and connect. In the picture, a SPH10 is connected to a PTB210 barometer.

Features/Benefits

- Minimizes wind induced error
- Easy-to-clean
- Reliable barometric pressure measurement in all weather
- Easy-to-install
- Wind tunnel tested structure

Technical data

General

Operating temperature	-60 ... +80 °C (-76 ... +176 °F)
Weight	
SPH10	800 g
SPH20	1360 g
Material	PC plastic, offshore aluminium
Mounting	with 2 bolts (M6 X 20 mm min)
Hose connection	barbed fitting for 4 mm I.D. hose or Rp1/4 thread (parallel)

SPH20

Electrical connections	M12 connector
Power supply	factory setting 12 V changed connection 24 V
Thermostat switching temperature	
On	+4 °C (±3 °C) +39.2 °F (±4.4 °F)
Off	+13 °C (±3 °C) +55.4 °F (±4.4 °F)
Power consumption during heating	70 W

Dimensions

Dimensions in mm

SPH10

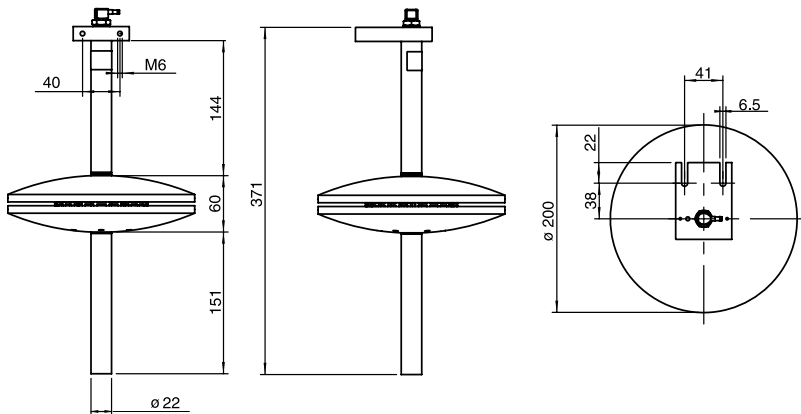

SPH20

