



Features

- Temperature accuracy up to 0.1 °C (0.18 °F)
- Temperature measurement range -70 ... +180 °C (-94 ... +356 °F)
- Modbus RTU over RS-485
- Plug & play compatible with Indigo™ series of transmitters
- Traceable 2-point calibration certificate (calibration points at +20 and +70 °C (+68 and +158 °F))

Vaisala Temperature Probe TMP1 is designed for demanding temperature measurements in industrial applications such as pharmaceutical industry and calibration laboratories, where accuracy and robustness are essential.

Flexible Connectivity

The probe is plug and play compatible with Vaisala Indigo™ series of transmitters, or it can be used as a standalone digital Modbus RTU transmitter over RS-485 serial bus. For easy-to-use access to field calibration, device analytics, and configuration functionality, the probe can be connected to Vaisala Insight™ Software (for Windows® 7, 8.1 and 10: see www.vaisala.com/insight).

Vaisala Indigo™ Product Family

Indigo transmitters offer a variety of connectivity options through analog signals or digital outputs, configurable relays, and wireless (WLAN) configuration interface, providing a suitable solution for all industrial humidity measurements. The cable

length between the probe and transmitter can be extended to up to 30 meters. For more information, see www.vaisala.com/indigo.

Relative Humidity Measurements in High Humidities

When the TMP1 probe is connected to a control system in parallel with HMP7 Relative Humidity and Temperature Probe, it is possible to have relative humidity measurement in actual process temperature while using probe heating in the relative humidity probe. Probe heating helps to avoid condensation in situations where the dew point temperature of the process is close to the ambient temperature.

When the humidity probe is heated above dew point temperature, condensation can be avoided and the relative humidity in the actual process temperature can be back-calculated based on the true process temperature measurement received from TMP1.

Services You Can Count On

Each probe is manufactured and individually calibrated in Vaisala's world-class facility in Finland. The traceable factory calibration certificate is included also in electronic format in the probe.

The interchangeable probes minimize the downtime associated with maintenance. Validate and maintain the accuracy by calibrating the instrument on the field or use the easy and thorough calibration service in Vaisala's service facilities in Helsinki, Boston, Beijing and Tokyo.

Technical Data

Measurement Performance

Sensor	Pt100 RTD Class F0.1 IEC 60751
Measurement range	-70 ... +180 °C (-94 ... +356 °F)
Accuracy at +23 °C (+73.4 °F) ¹⁾	±0.1 °C (±0.18 °F)

¹⁾ Defined against calibration reference

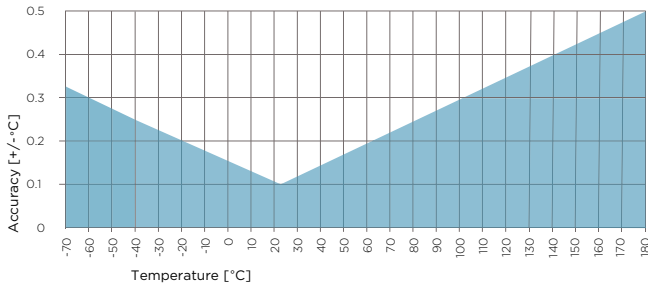

TMP1 Temperature Measurement Accuracy over Full Range (Including Non-Linearity and Repeatability)

SI Traceable Calibration

Uncertainty of temperature calibration ±0.1 °C (±0.18 °F) at +23 °C (+73.4 °F) (k = 2)

Operating Environment

Operating temperature range for probe body	-40 ... +80 °C (-40 ... +176 °F)
Operating temperature range for probe head	-70 ... +180 °C (-94 ... +356 °F)
Operating environment	Suitable for outdoor use
IP rating	IP66
Electromagnetic compatibility	Complies with EMC standard EN61326-1, Industrial Environment

Inputs and Outputs

Operating voltage	15 ... 30 VDC
Current consumption	10 mA typical
Digital output	RS-485, non-isolated
Default serial settings	19200 bps N 8 2
Protocols	Modbus RTU
Output parameters	Temperature, water vapor saturation pressure

Mechanical Specifications

Connector	M12/5
Weight	224 g (7.9 oz)
Materials	
Probe	AISI316L
Probe body	AISI316L
Cable jacket	FEP

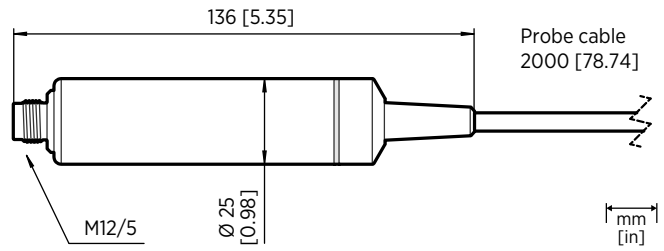

Probe Body Dimensions

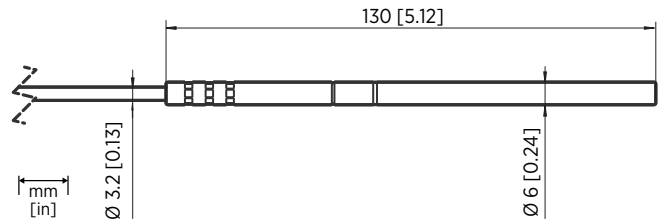

TMP1 Probe Head Dimensions

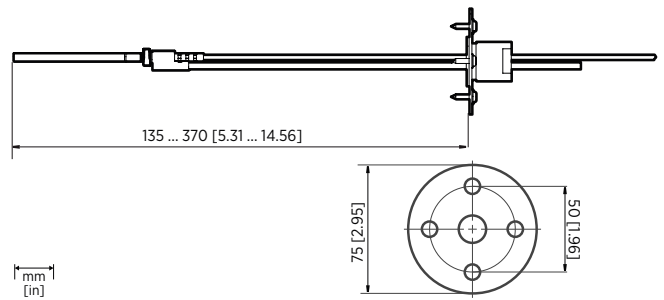

Optional Duct Kit 215003 Dimensions

Accessories

Transmitters

Indigo 200 Series	See order form
-------------------	----------------

Connection Cables

Connection cable to Indigo (1 m)	INDIGOCABLE1M
Connection cable to Indigo (3 m)	INDIGOCABLE3M
Connection cable to Indigo (5 m)	INDIGOCABLE5M
Connection cable to Indigo (10 m)	INDIGOCABLE10M
Open wires 1.5 m	223263SP
Open wires 10 m	216546SP
Open wires and 90° plug	244669SP
Flat cable 1 m M12/5	CBL210493SP
USB PC connection cable ¹⁾	242659

Accessories

Duct installation kit for T probe	215003
Swagelok for 6 mm probe 1/8" ISO thread	SWG6ISO18
Swagelok for 6 mm probe 1/8" NPT thread	SWG6NPT18

¹⁾ Vaisala Insight software for Windows available at www.vaisala.com/insight