

SATRON VDU differential pressure transmitter belongs to V-series transmitters. SATRON VDU differential pressure transmitter is used from 0-1.4 kPa to 0-3 MPa ranges. It is a 2-wire transmitter with HART® standard communication. In pressure measuring applications SATRON VDU diff. pressure transmitters are used for measuring the pressure of clean, sedimenting, crystallizing and sticking materials. The transmitter's sensor is piezoresistive. The rangeability is 25:1.

TECHNICAL SPECIFICATIONS

Measuring range and span

See Selection Chart.

Zero and Span adjustment

Zero elevation: Calibrated span is freely selectable on the specified range. This can be made by using keyboard or HART®275 communicator.

Damping

- Time constant is continuously adjustable 0,01 to 60 s.

Temperature limits

Ambient: -30 to +80 °C
Process: -30 to +125 °C
0 to +200 °C (temp. code **H**)
Shipping and storage: -40 to +80 °C.
Operating temperature of display: 0 to +50°C (does not affect operation of the transmitter)

Pressure limits Min. and max. process pressure: See the appended tables.

Volumetric displacement

< 0.5 mm³/max. span (in both sensors)

Output 2-wire (2W), 4-20 mA, user selectable for linear, square root, inverted signal or the transfer function (16 points) specified by the user

Supply voltage and permissible load

See the load capacity diagram;
4-20 mA output: 12 - 35 VDC.

Humidity limits

0-100 % RH; freezing of condensed water not allowed in reference pressure channels.

PERFORMANCE SPECIFICATIONS

Tested in accordance with IEC 60770: Reference conditions, specified span, no range elevation, horizontal mounting; AISI316L diaphragm, silicone oil fill.

Accuracy

±0.2 % of calibrated span
(span 1:1-7.5:1 / max. range).
On the measuring ranges 7.5:1-25:1:

$$\pm[0.02+0.024 \times \left(\frac{\text{max. span}}{\text{calibrated span}}\right)]\% \text{ of calibrated span}$$

Special accuracy types **BA** and **DA** : (Temperature effect on +20 to +70 °C) ±0,15 % of calibrated span, only process connections **BA** and **DA** / temperature effect code **S**, for spans 1:1-7,5:1).

¹⁾ Parts in contact with process medium

On the measuring ranges 7,5:1-25:1:

$$\pm[0.01+0.007 \times \left(\frac{\text{max. span}}{\text{calibrated span}}\right)]\% \text{ of calibrated span}$$

(incl. nonlinearity, hysteresis and repeatability)

Long-term stability

±0.2 % / max. span / year

Temperature effect

- on -20 to +80 °C range

Zero and span error:
±0.3 % of max. span.

- on 0 °C to +200 °C range

(process temperature code **H**)
±2 % of max. span, VDU6
±4 % of max. span, VDU4, VDU5

Temperature effect

- on +20 °C to +70 °C,

process connections **BA** and **DA**
Zero and span error:
±0.15 % of max. span, code **S**

Mounting position effect

Zero error < 0.32 kPa, which can be calibrated out.

Vibration effect (IEC 68-2-6: FC):

±0.1 % of measuring range/
2g/10 to 2000 Hz
4g/10 to 100 Hz

Power supply effect

< ±0.01 of calibrated span per volt

Insulation test voltage

500 V rms 50 Hz

CONSTRUCTION AND CALIBRATION Materials

Diaphragm ¹⁾: AISI316L (EN 1.4435), Duplex (EN 1.4462), Hast. C276 (EN 2.4819), CoNi-alloy, Titanium Gr2 (EN 3.7035), Nickel or Tantalum.

Coupling ¹⁾: AISI316L (EN 1.4404), Duplex (EN 1.4462), Hast.C276 (EN 2.4819) or Titanium (EN 3.7035)

Other sensing element materials: AISI316, AISI303.

Pressure limits

Maximum process pressure

Transmitter type	Max. overload pressure, MPa	Pressure class
VDU3	0.25	PN40
VDU4	0.3	PN40
VDU5	1.5	PN40
VDU6	7.5	PN100



Filling fluid: Silicone oil, food industry oil or inert oil

Enclosure class IP66

Electronics housing:

AISI303/316, Seals: nitrile rubber and Viton®, Nameplates: Polyester

Calibration

For customer-specified range with 1 s. damping. (If range is not specified, transmitter is calibrated for maximum range.)

Process connections

See Selection Chart
Process couplings: See Selection Chart and installation instructions or technical specification: Couplings for Transmitters **G150**.

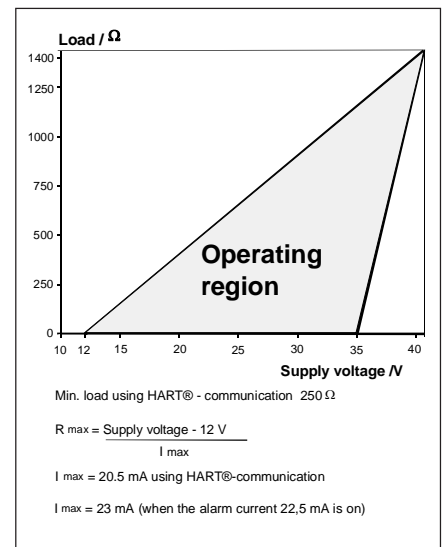

Minimum process pressure

T _{proc.} °C	Minimum pressure for different fill fluids (kPa, abs.)	
	DC200 100 cSt	Inert oil
20	5	8
40	8	10
80	16	28
120	21	53

Electrical connections

M20x1.5, 1/2-NPT ; screw terminals for 0.5 to 2.5 mm² wires and with PLUG connector, connector type DIN 43650 model AF; Pg9 gland for cable; wire gross-section 0.5 to 1.5 mm².

Product Certifications

European Directive Information

Electro Magnetic Compatibility (EMC directive 2004/108/EC)

All differential pressure transmitters
European Pressure Equipment Directive (PED) (97/23/EC)

All Differential Pressure Transmitters:
- Sound Engineering Practice

Weight

Mounting type	Weight / kg				
	Extension code				
	0	2	4	6	
Flange	DN50	8.8	10	10.5	11
	DN80	13.5	15.8	16	16.8
SA (Sandvik)	-	8.2	10.6	12.8	
Tx (Tri-Clamp)	2.4	-	-	-	
PA (PMC 1")	1.8	-	-	-	
BA, VA, WA	1.8	-	-	-	
UA, VB, WB	2.6	-	-	-	
G1...G4	2.5	-	-	-	

Dimensions (mm)

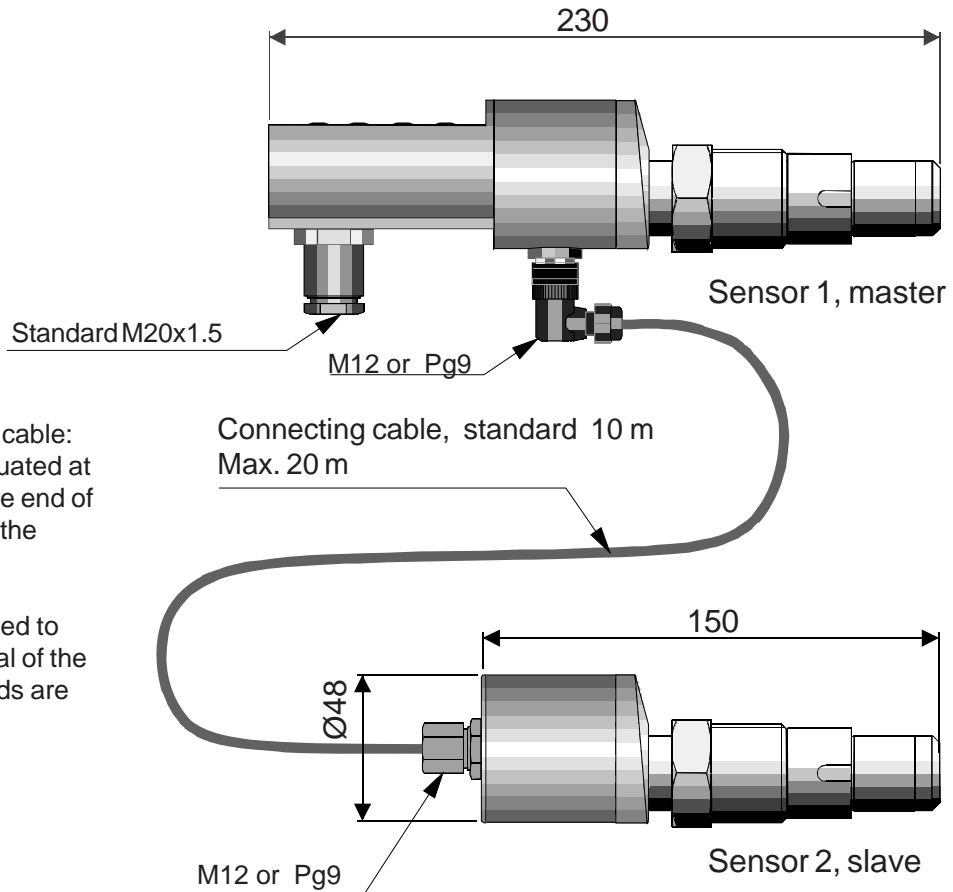

Dimensions (mm)

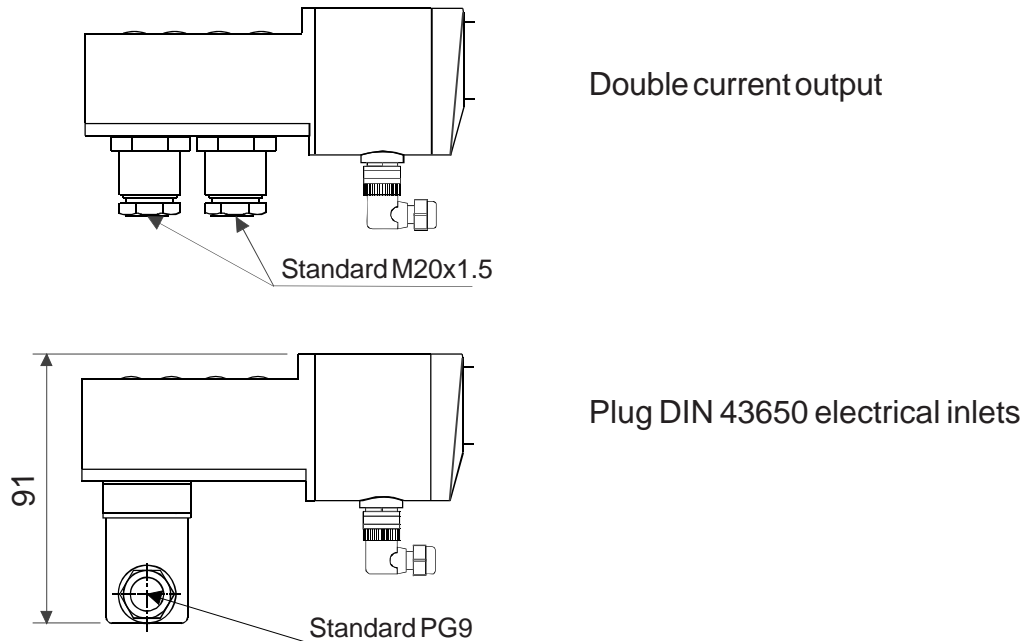

Dimensions (mm)

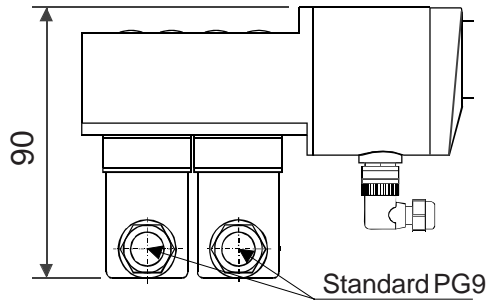

Double current output with
plug DIN43650 connector

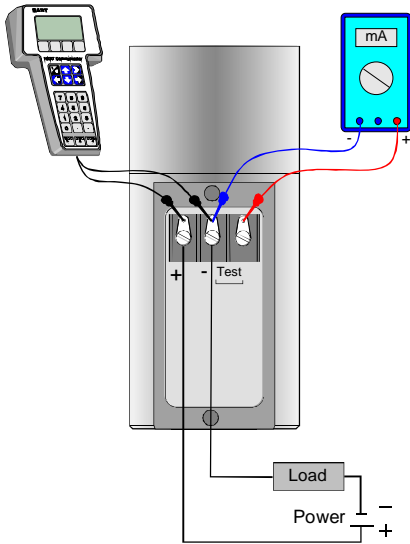
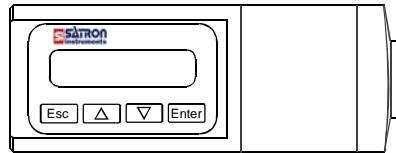

Wiring one current output

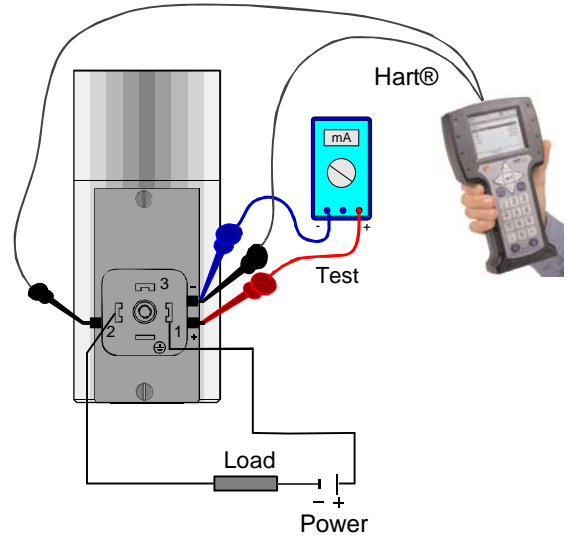

Wiring one current output, plug DIN43650 connector

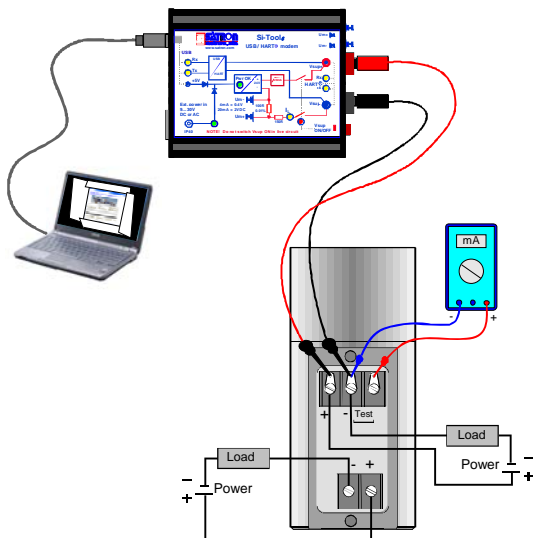

Wiring double current output

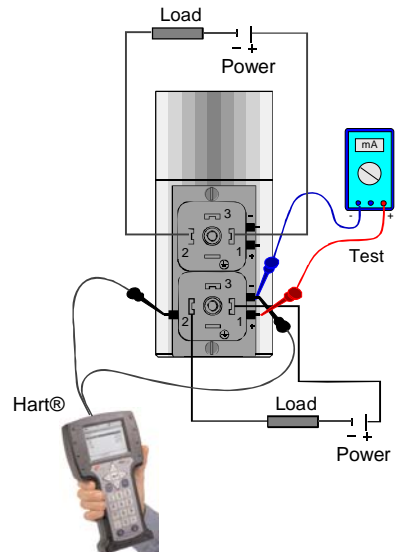

Wiring double current output, plug DIN 43650 connector

Dimensional drawings (dimensions in mm)

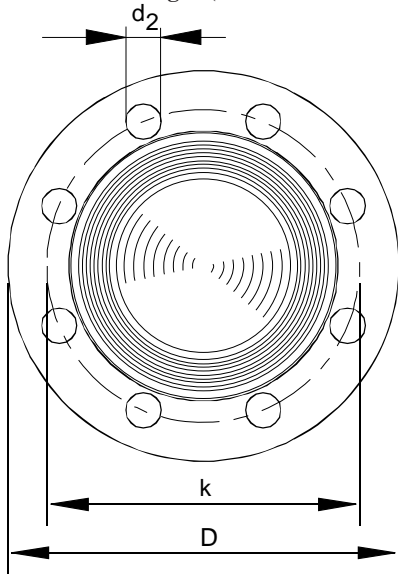

Sensor 1 (master) 275
Sensor 2 (slave) 190

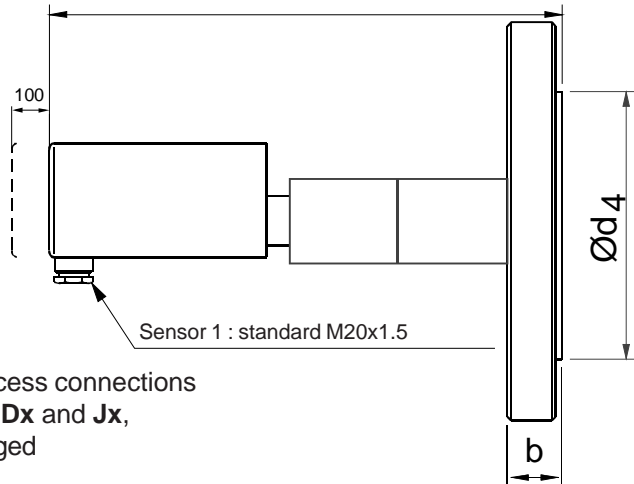

Process connections
Ax, Dx and Jx,
flanged

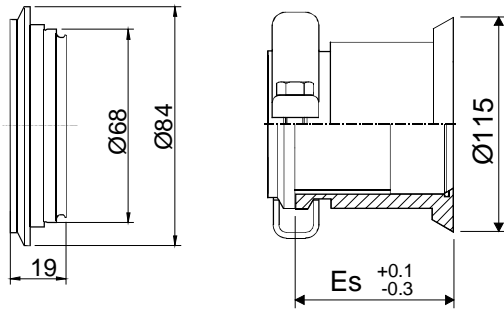

Process connection **UA**,
- Tuchenhagen DN50/40
(Varivent®)

Process connection **SA**,
- Sandvik-clamp

Sensor 1 (master) 225
Sensor 2 (slave) 145

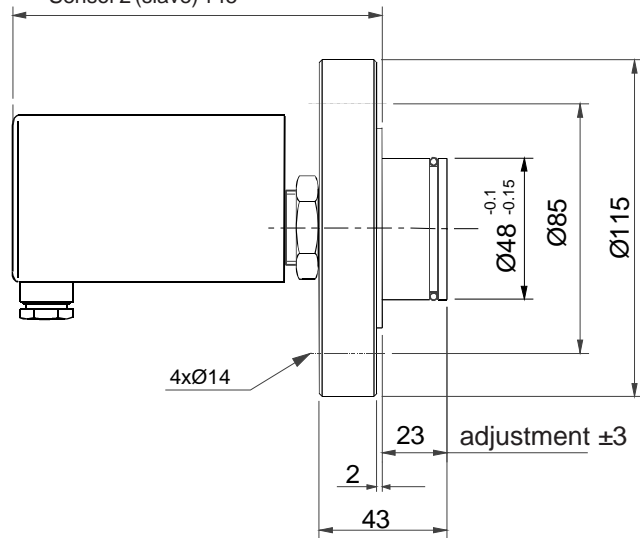

Process connection **DA**, DN25 PN40 flange with
extension, process temperature max. +125°C

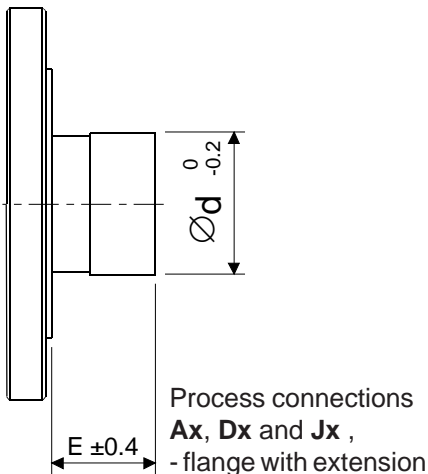

Process connections
Ax, Dx and Jx ,
- flange with extension

Code	E +0.4 -0.4	Es +0.3 -0.2
0	0	-
1	23	-
2	51	54,5
4	102	105
6	152	156

FLANGE SIZE	Flange dimens.			Holes			Extens. Ød -0.2
	b	D	Ød ₄	pcs	d ₂	k	
ISO DN25 PN40	18	115	68	4	14	85	48
ISO DN50 PN40	20	165	102	4	18	125	51
ISO DN80 PN40	24	200	138	8	18	160	73
ISO DN100 PN40	24	235	162	8	22	190	73
ANSI 1" 150 lbs	15	108	51	4	16	79.4	-
ANSI 1" 300 lbs	18	124	51	4	20	88.9	-
ANSI 2" 150 lbs	23	152	92	4	20	120.6	51
ANSI 2" 300 lbs	25	165	92	8	20	127	51
ANSI 3" 150 lbs	26	191	127	4	20	152.4	73
ANSI 3" 300 lbs	31	210	127	8	23	168.3	73
ANSI 4" 150 lbs	26	229	157	8	20	190.5	73
ANSI 4" 300 lbs	34	254	157	8	23	200	73
JIS 10K-50	16	155	96	4	19	120	51
JIS 40K-50	26	165	105	8	19	130	51
JIS 10K-80	18	185	126	8	19	150	73
JIS 40K-80	32	210	140	8	23	170	73
JIS 10K-100	18	210	151	8	19	175	73
JIS 40K-100	36	250	165	8	25	205	73

Dimensional drawings (dimensions in mm)

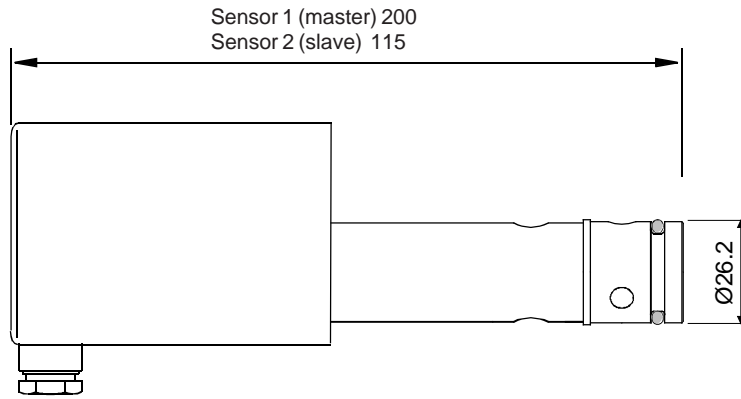

Process connection **PA**
- PMC 1"

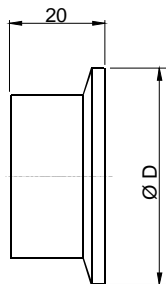
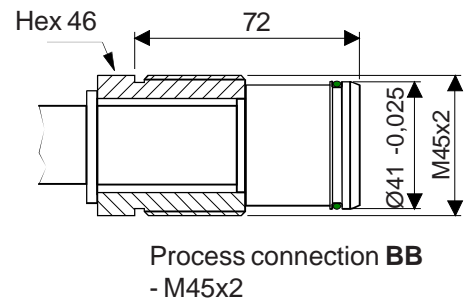
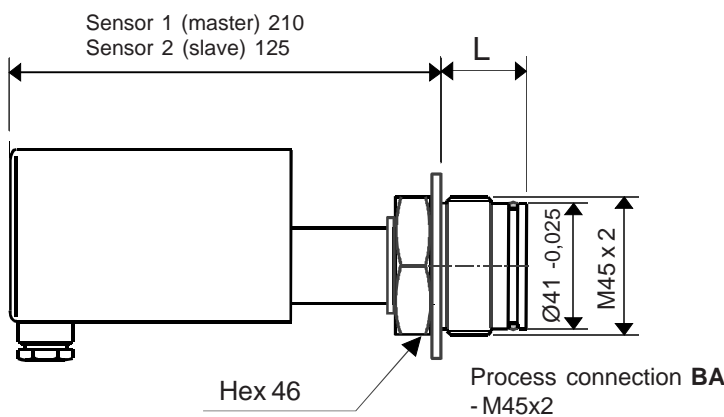

Process connections **TA , TB and TC**
- Tri-clamp DN38 ... 63,5

DN	ØD
38	50.5
51	64
63.5	77.5

BA - extension code	L
0	28,5
2	51
3	72
4	102

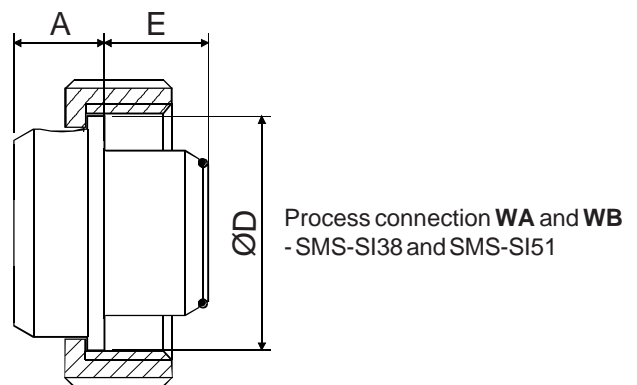
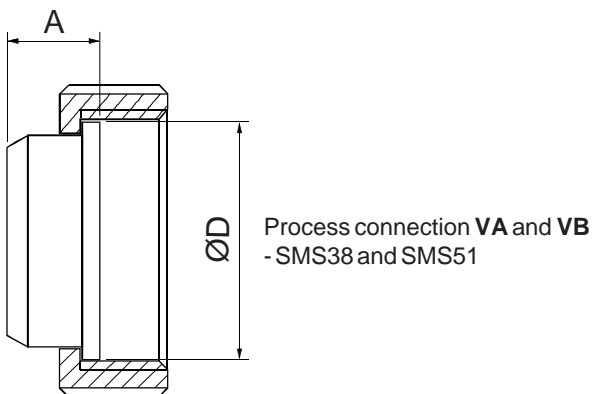

Size	Dimensions		Thread
	ØD	A	
38	54	21	Rd 60 x 1/6
51	64	23	Rd 70 x 1/6

Size	Dimensions			Thread
	ØD	A	E	
SI38	54	21	24	Rd 60 x 1/6
SI51	64	23	27	Rd 70 x 1/6

Selection Chart

Adjustability	Span, min	Span, max.	Measuring range
VDU3	1.4kPa (14 mbar)	35 kPa (350 mbar)	-35...+35 kPa (-350...350 mbar)
VDU4	4kPa (40 mbar)	100 kPa (1000 mbar)	-100...+100 kPa (-1000...1000 mbar)
VDU4/5	4kPa (40 mbar)	250 kPa (2500 mbar)	-100...+250 kPa (-1000...2500 mbar)
VDU5	26.5 kPa (265 mbar)	500 kPa (5000 mbar)	-100...+500 kPa (-1000...5000 mbar)
VDU5/6	26.5 kPa (265 mbar)	1 MPa (10 bar)	-0.1...+1 MPa (-1... 10 bar)
VDU6	0.145 MPa (1.45 bar)	3 MPa (30 bar)	-0.1...+3 MPa (-1...30 bar)

Output **S** 4-20mA DC/HART® **D** 4-20mA DC/HART® and with galvanic isolation 4-20mA

Process connections

DA DN25 PN40 ISO 2084-1974	AB ANSI 1" 300 lbs ANSI B16-5	UA Tuchenhagen DN50/40 (Varivent®) PN40
DB DN50 PN40 ISO 2084-1974	AC ANSI 2" 150 lbs ANSI B16-5	PA PMC 1" PN40
DC DN80 PN40 ISO 2084-1974	AD ANSI 2" 300 lbs ANSI B16-5	SA Sandvik DN70 PN64
DD DN100 PN40 ISO 2084-1974	AE ANSI 3" 150 lbs ANSI B16-5	BA M45x2 PN160
JA JIS 10K 50 JIS B 2220	AF ANSI 3" 300 lbs ANSI B16-5	BB M45x2 PN160
JB JIS 40K 50 JIS B 2220	AG ANSI 4" 150 lbs ANSI B16-5	G4 G1 thread, metal/metal taper sealing
JC JIS 10K 80 JIS B 2220	AH ANSI 4" 300 lbs ANSI B16-5	G5 G1 thread, FPM 0-ring sealing (**) (1)
JD JIS 40K 80 JIS B 2220	TA Tri-clamp DN38 PN40 ISO 2852	G6 G1 thread, EPDM 0-ring sealing (**) (1)
JE JIS 10K 100 JIS B 2220	TB Tri-clamp DN51 PN40 ISO 2852	VA SMS 38
JF JIS 40K 100 JIS B 2220	TC Tri-clamp DN63.5 PN40 ISO 2852	VB SMS 51
AA ANSI 1" 150 lbs ANSI B16-5		WA SMS-SI 38 with extension 24 mm
		WB SMS-SI 51 with extension 27 mm

Extension length (mm)	(Flanged conn.)	(Sandvik conn.)	
0	0	-	(not proc.conn. SA)
1	23	-	(only proc.conn. DA1, DN25 PN40, max. +125 °C)
2	51	54.5	(not proc.conn. BB, VA, VB, WA, WB, Tx, UA, PA, DA, G1, G2, G4)
3	72	-	(only proc.conn. BA)
4	102	105	(not proc.conn. BB, VA, VB, WA, WB, Tx, UA, PA, DA, G1, G2, G4)
6	152	156	(not proc.conn. BB, VA, VB, WA, WB, Tx, UA, PA, DA, G1, G2, G4)

Wetted materials

Diaphragm

Code	Material	Code	Material	Code	Material	Code	Material
1	Nickel (x) (*) (***)	5	Tantalum (*) (***)	2	AISI316L	9	gold/Rhodium
2	AISI316L	6	Titanium (xx) (*) (***)	3	Hast.C 276	Y	diamond (specify only when coated)
3	Hast.C 276 (*) (***)	8	Duplex (*) (***)	8	Duplex		

Extension or other wetted parts

Diaphragm coating

Filling oil **S** Silicone oil **G** Inert oil **A** Food industry oil (Neobee M20)

Housing type, master

N Housing with junction box/terminal strip, display, inlet M20x1,5

Explosion proof **0** No explosion proof classification

Process temperature **N** -30 ... +125 °C **H** 0 ... +200 °C (*) (***)
S +20 ... +70 °C (only process connections **BA** and **DA**)

Cable between sensors

- 1** PUR cable with M12 connector both end of cable
- 2** PVC cable with AISI316/ PG9 inlet, fixed factory mounted



Process couplings

- 0** Will be ordered separately
- A** With coupling

Material

- 2** AISI316L
- 3** Hast.C276
- 6** Titanium
- 8** Duplex

Special sizes of electrical inlets (Standard M20x1.5)

N 1/2 NPT **G** Pg13.5 **P** PLUG connector, DIN43650

Documentation

Calibration certificate **AE** English

Installation and Operating Instructions **IE** English **IF** Finnish

Material certificates

- 0** No material certificate
- MC1** Raw material certificate without appendixes, in accordance with SFS-EN 10204-2.1 (DIN 50049-2.1) standard
- MC2** Raw material certificate for wetted parts, in accordance with SFS-EN 10204-2.2 (DIN 50049-2.2) standard
- MC3** Raw material certificate for wetted parts, in accordance with SFS-EN 10204-3.1 B (DIN 50049-3.1 B) standard

(x) = only with flange
 (xx) = only with flange and G4
 (1) = EHEDG - certified

(*) = not proc.conn. G5 and G6
 (**) = not for range 3
 (***) = not for range 3 with process connection code G4

Process couplings, G1 thread

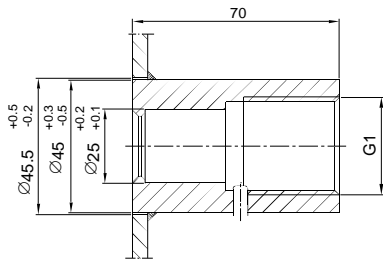

Standard coupling

Material: AISI316 L, Titanium or Hastelloy C

Special couplings, e.g.:

- G1 hygienic coupling, M548101
- G1/2A/G1 coupling, M546190
- G1/2A/G1 coupling with venting, M860280
- G1/2A/G1 couplings with bracket:
 - G1/2A male, M546195
 - G1/2 female, M550393

Transmitter's process sealing G1 thread

Three different options are available for the transmitter's process sealing:

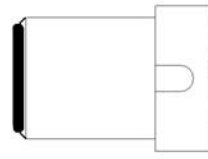
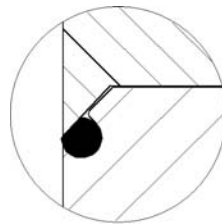

AISI316L, AISI317L or Duplex diaphragm, o-ring **FPM** (Viton) (code **G5**)
EHEDG - certified

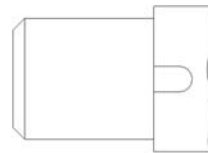
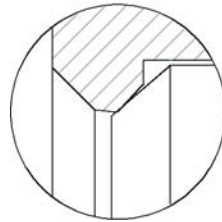

AISI316L, AISI317L or Duplex diaphragm, o-ring **EPDM** (code **G6**)
EHEDG - certified

AISI316L, CoNi-, Duplex, Hastelloy C276 or Tantalum diaphragm, metal/metal taper sealing (diaphragm on sealing face) (code **G4**)

SMS-SI couplings :

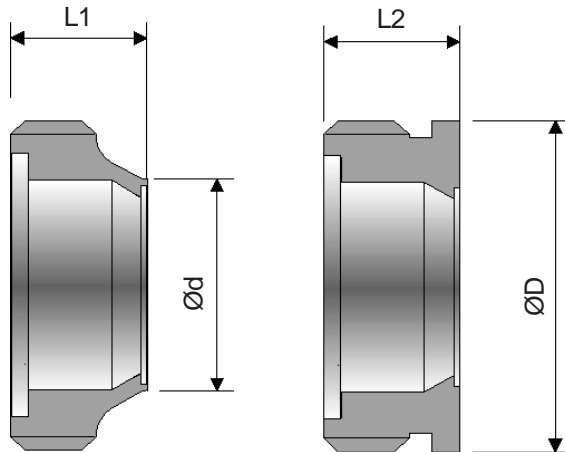

for pipe

for vessel

Size	Dimensions				Thread
	L1	Ød	L2	ØD	
38	27	38,5	24	60	Rd 60 x 1/6
51	30	51	25	70	Rd 70 x 1/6

Coupling M45x2 with adjust, for process connection BA, order code M1050459

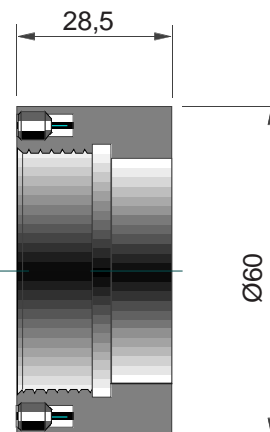

Passive BA working position:

For process connections **BA3** and **BB**

1. Transmitter in measuring
2. Transmitter can be checked, changed, calibrated or the transmitter diaphragm can be flushed

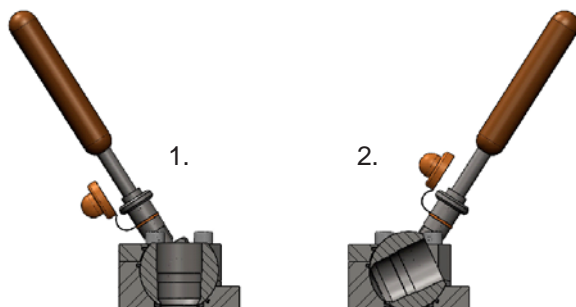

Coupling BB M45x2, for process connection BB, order code M1050474 (Welding assistant, code M1050473)

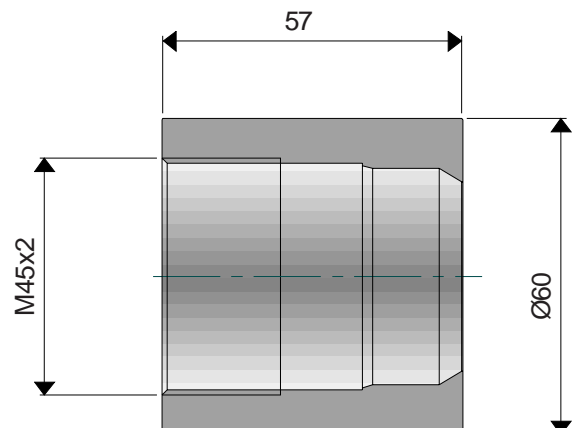

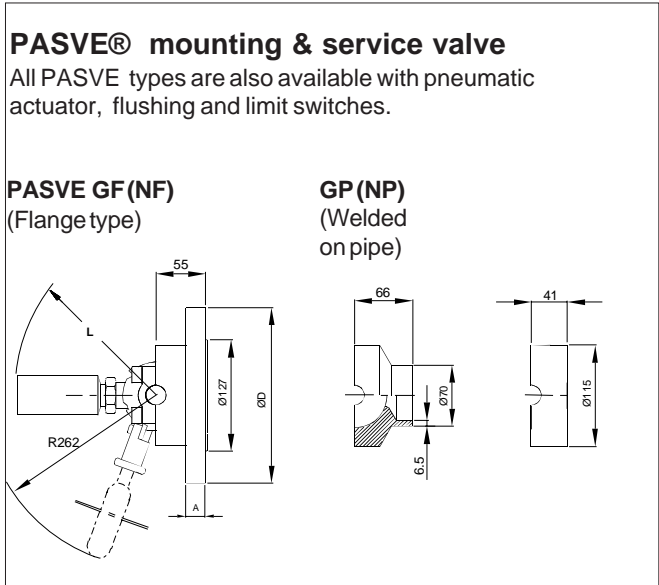
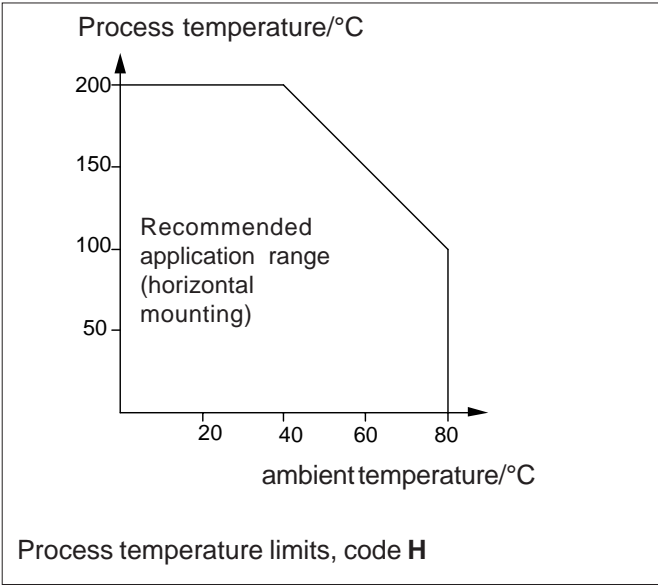

Keyboard :

- Esc = Press **Esc** move back towards the top of the main menu.
- ▲ = Use the **UP** arrow key to move up on the current menu level or to increase the selected parameter value.
- ▼ = Use the **DOWN** arrow key to move down on the current menu level or to decrease the selected parameter value.
- Enter = Press **ENTER** to move to a lower level in a menu or to accept a command or parameter value.



Satron Instruments Inc., P.O.Box 22, FIN-33901 Tampere, Finland
Tel. +358 207 464 800, Telefax +358 207 464 801, www.satron.com

We reserve the right for technical modifications without prior notice.

HART is a registered trademark of HART Communication Foundation.
Pasve is a trademark of Satron Instruments Inc.
Hastelloy is the registered trademark of Haynes International.
Teflon is the registered trademark of E.I. du Pont de Nemours & Co.
Viton is the registered trademark of DuPont Down Elastomer.
Varivent is a registered trademark of GEA Tuchenhagen.

