

SATRON VL Pressure Transmitter

BLV820
M2, revision 2
15.2.2013

SATRON VL pressure transmitter belongs to the V transmitter family. The series V transmitters have both analog and smart properties. SATRON VL is used for 0-1.4 kPa...0-15 MPa ranges. It is a 2-wire transmitter with HART® standard communication. In pressure measuring applications SATRON VL transmitters are used for measuring the pressure of clean, sedimenting, crystallizing and sticking materials. The transmitter's sensor is piezoresistive. The rangeability is 100:1 for types VL6 - VL7. The versatile selection of diaphragm materials will meet the needs in most processes. Also the models with special accuracy are included to the series of VL transmitters.



TECHNICAL SPECIFICATIONS

Measuring range and span

See Selection Chart.

Zero and Span adjustment

Zero elevation: Calibrated span is freely selectable on the specified range depending from the desired option. This can be made by using external control shafts (analog option), keyboard (display option), HART®/275/375 communicator.

Damping

Time constant is continuously adjustable 0.01 to 60 s.

Temperature limits

Ambient: -30 to +80 °C
Process: -30 to +125 °C / +200 °C
Shipping and storage: -40 to +80 °C.
Operating temperature of display: 0 to +50°C (does not affect operation of the transmitter)

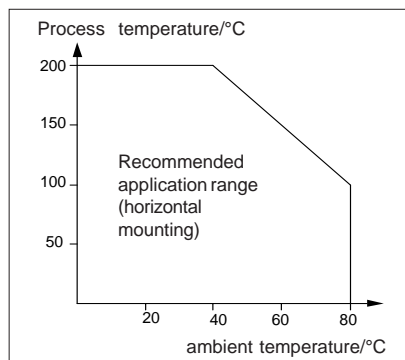

Output 2-wire (2W), 4-20 mA, user selectable for linear, square root, inverted signal or the transfer function (16 points) specified by the user

Supply voltage and permissible load

See the load capacity diagram;
4-20 mA output: 12-35 VDC.

Humidity limits

0-100 % RH; freezing of condensed water is not allowed in reference pressure channels.

Pressure limits

Minimum and maximum process pressure: see the appended tables.

PERFORMANCE SPECIFICATIONS

Tested in accordance with IEC 60770: Reference conditions, specified span, no range elevation, horizontal mounting; AISI316L diaphragm, silicone oil fill

Accuracy

±0.1 % of calibrated span
(For spans 1:1-7.5:1).

For spans 7.5:1-100:1,

$\pm [0.025 + 0.01 \times (\frac{\text{max. span}}{\text{calibrated span}})]$ % of calibrated span

Special accurate models **BA** and **DA** :
(Temperature effect on +20°C to +70°C)

±0.075 % of calibrated span
(For spans 1:1-7.5:1).

For spans 7.5:1-100:1,

$\pm [0.015 + 0.008 \times (\frac{\text{max. span}}{\text{calibrated span}})]$ % of calibrated span

(incl. nonlinearity, hysteresis and repeatability)

Long-term stability

• ±0.1 % of max. span / 1 year

Temperature effect on -30 °C to +80 °C range, optional

Zero and span error
• ±0.15 % of max. span, code **E**
• ±0.5 % of max. span, code **G**

Temperature effect on +20 °C to +70 °C range, process connections BA and DA

Zero and span error
• ±0.08 % of max. span, code **S**

Temperature effect on 0 to +200 °C, code H

• ±1 % of max. span

• Process connection **PA** (VL4 and 5):
±2 % of max. span

Mounting position effect

Deviation from horizontal position causes a zero shift that can be calibrated out.

Vibration effect (IEC 68-2-6: FC):

±0.1 % of span per 2 g to 10-2000 Hz.

Power supply effect

<±0.01 % of calibrated span per volt.

Insulation test voltage

500 V rms 50 Hz.

CONSTRUCTION AND CALIBRATION

Materials

Diaphragm ¹⁾: AISI316L (EN 1.4435), Duplex (EN 1.4462), Hast. C 276 (EN 2.4819), Tantalum or Titanium Gr2 (EN 3.7035).
Other sensing element materials: AISI316L, AISI316.

Fill fluid Silicone oil, inert oil or Food oil (Neobee M20).

Housing with PLUG connector, codes H and T

Housing: AISI303/316
Seals: Viton® and NBR
TEST jacks: MS358Sn/PVDF, protected with silicone rubber shield.
PLUG connector: PA6-GF30 jacket, Silicone rubber seal, AISI316 retaining screw.

Housing with junction box/terminal strip, codes M and N

Housing: AISI303/316; Seals: Nitrile and Viton®; Nameplates: Polyester

Connection cable between sensing element and housing

Codes **L** and **K** :
PTFE hose with AISI316 braiding.

Pressure limits

Pressure capacity

Transmitter type	Max. over-load pressure, MPa	Pressure class, max.
VL3	0.2	PN40
VL4	0.3	PN40
VL5	1.5	PN40
VL6	7.5	PN100
VL7	40.0	PN250

Minimum process pressure:

T _{proc.} °C	Min. pressure for different fill fluids (kPa, abs.)	
	DC200 100 cSt	Inert oil
20	5	8
40	8	10
80	10	28
120	15	53
160	25	90
200	40	-

¹⁾ Parts in contact with process medium.

Calibration

For customer-specified range with 1 s. damping. (If range is not specified, transmitter is calibrated for maximum range.)

Enclosure class: IP66.

Process connections

See Selection Table and dimensional drawings.

Electrical connections

Housing with PLUG connector, codes **H** and **T**: PLUG connector, connector type DIN 43650 model AF; Pg9 gland for cable; wire cross-section 0.5 to 1.5 mm².

Housing with junction box/terminal strip, codes **M** and **N**: Pg13.5, 1/2-NPT inlet; screw terminals for 0.5 to 2.5 mm² wires.

Weight

MOUNTING TYPE		Weight / kg			
		EXTENSION CODE			
		0	2	4	6
Flange	DN50	4.1	4.7	4.9	5.1
	DN80	6.4	7.6	7.7	8.1
SA (Sandvik)		-	3.8	5.0	6.1
Tx (Tri-Clamp)		0.9	-	-	-
PA (PMC 1")		0.6	-	-	-
BA, VA, WA		0,9	-	-	-
UA, VB, WB		1.0	-	-	-

Type M : add 0.5 kg
and type N : add 0.6 kg to the specified weights.

Product Certifications

European Directive Information

Electro Magnetic Compatibility (EMC directive 2004/108/EC)

All pressure transmitters

Atex Directive (94/9/EC)

Satron Instruments Inc. complies with the ATEX Directive.

European Pressure Equipment Directive (PED) (97/23/EC)

All Pressure Transmitters :
- Sound Engineering Practice

Hazardous Locations Certifications

European Certifications

ATEX Intrinsic Safety

Certification No. : DNV-2007-OSL-ATEX- 1346X

 II 1 GD T135°C EEx ia II C T4 - 20°C ≤ Tamb ≤ 50°C

 II 2 GD T135°C EEx ia II C T4 - 20°C ≤ Tamb ≤ 50°C

Input Parameters :

U_i = 28 V
I_i = 93 mA
P_i = 0.651 W
C_i = 5 nF
L_i = 0.2 mH

Special Conditions for Safe Use (X) :

The enclosure with plastic window and the plastic DIN43650 connector must not be installed in potentially explosive atmosphere requiring category 1 apparatus. The non-conducting surface of the sensor element may be charged by the flow of non-conducting media, so there may be electrostatic hazard with IIC-gases. These units should be marked 2 GD. The equipment shall be installed and connected according to the manufacturers instructions.

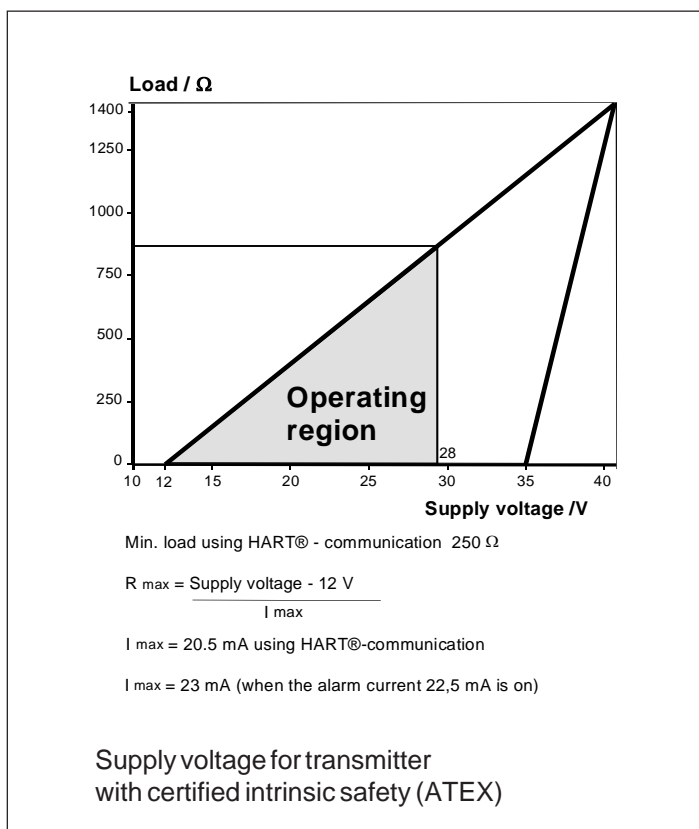
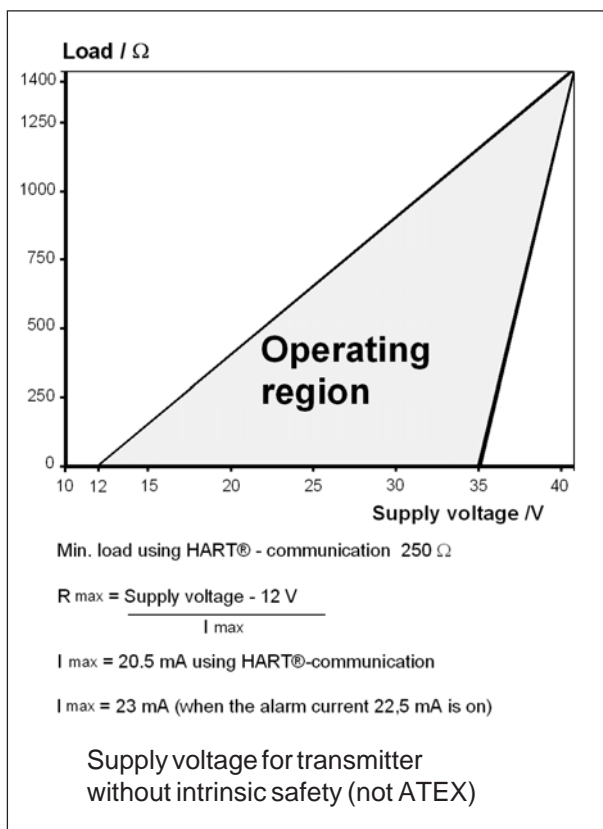

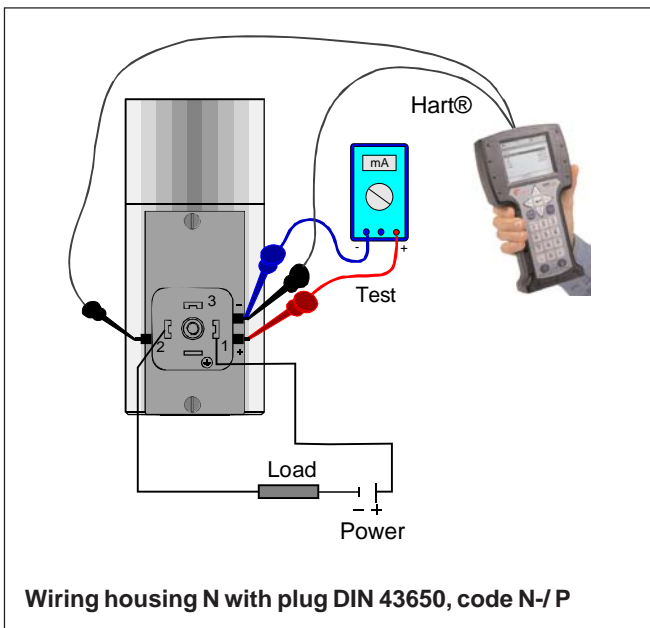
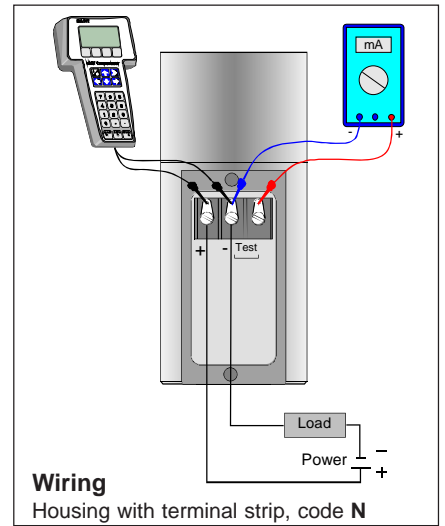
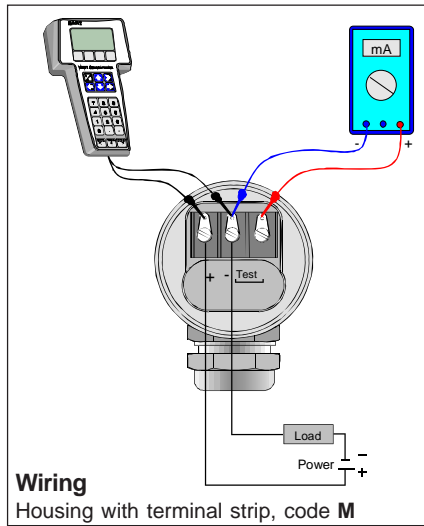
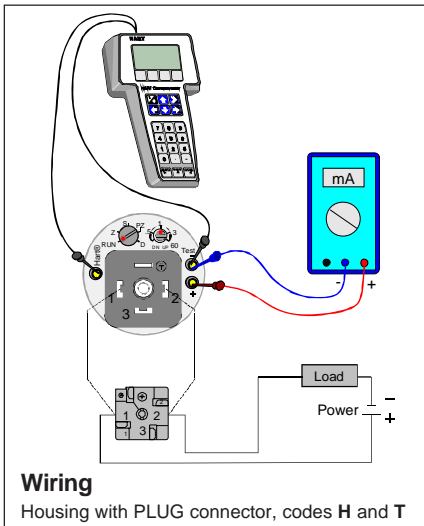

Keyboard :

- Esc = Press **Esc** move back towards the top of the main menu.
- ▲ = Use the **UP** arrow key to move up on the current menu level or to increase the selected parameter value.
- ▼ = Use the **DOWN** arrow key to move down on the current menu level or to decrease the selected parameter value.
- Enter = Press **ENTER** to move to a lower level in a menu or to accept a command or parameter value.

Housing with display, code N

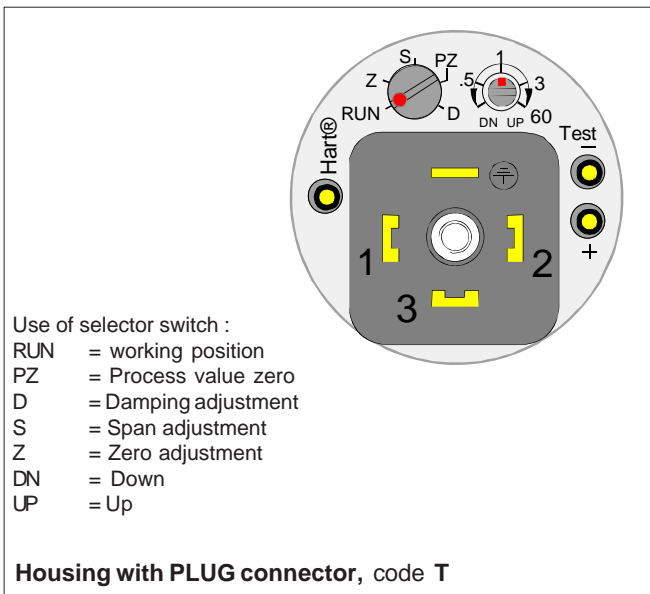

SATRON VL Pressure Transmitter

Dimensional drawings (dimensions in mm)

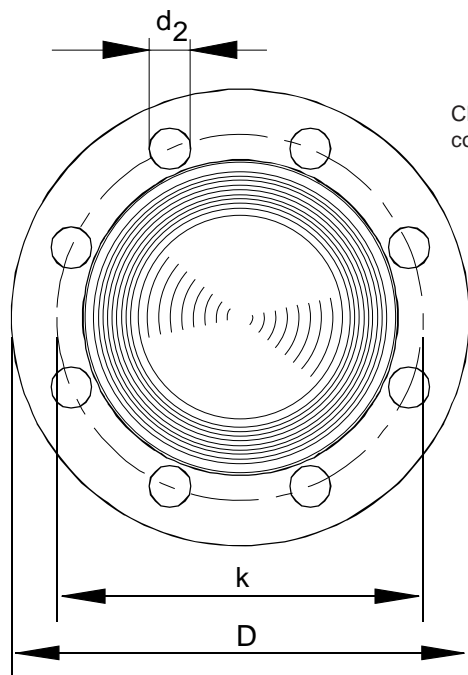

Housing types H, T and M 235

Housing type N 265

[Atex transmitter code 1, +15]

Clearance for cover removal

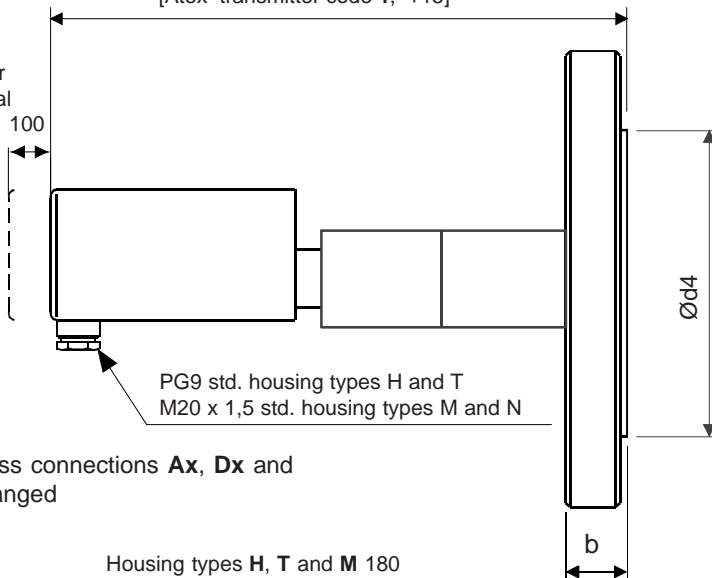

PG9 std. housing types H and T
M20 x 1,5 std. housing types M and N

Process connections Ax, Dx and Jx, flanged

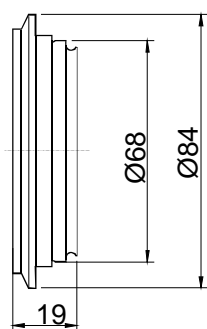

Process connection UA
- Tuchenhagen DN50/40
(Varient)

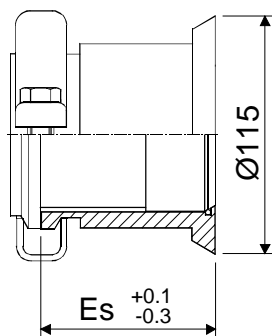

Process connection SA
- Sandvik-clamp

Housing types H, T and M 180

Housing type N 215

[Atex transmitter code 1, +15]

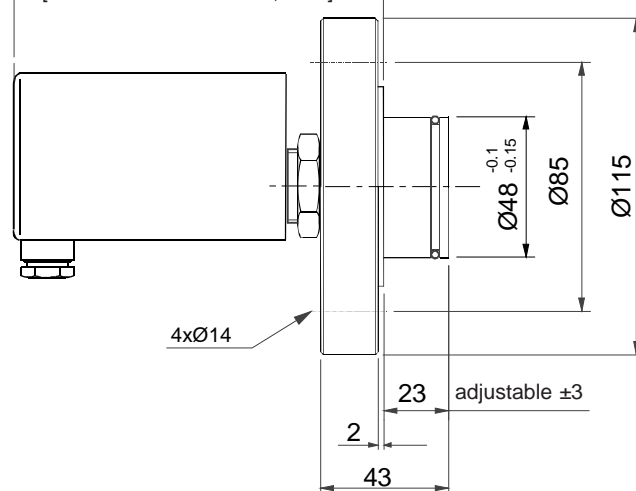

Process connections DA, DN25 PN40 flange with extension, process temperature max. +125°C

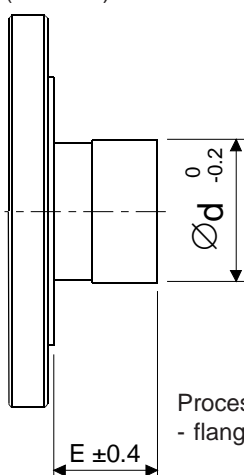

Process connection Ax, Dx and Jx
- flange with extension

Code	E +0.4 -0.4	Es +0.3 -0.2
0	0	-
2	51	54,5
4	102	105
6	152	156

FLANGE SIZE	Flange dimens.			Holes			Exten. $\text{Ø}d - 0.2$
	b	D	$\text{Ø}d_4$	Kpl	d_2	k	
ISO DN25 PN40	18	115	68	4	14	85	48
ISO DN50 PN40	20	165	102	4	18	125	51
ISO DN80 PN40	24	200	138	8	18	160	73
ISO DN100 PN40	24	235	162	8	22	190	73
ANSI 1" 150 lbs	15	108	51	4	16	79.4	-
ANSI 1" 300 lbs	18	124	51	4	20	88.9	-
ANSI 2" 150 lbs	23	152	92	4	20	120.6	51
ANSI 2" 300 lbs	25	165	92	8	20	127	51
ANSI 3" 150 lbs	26	191	127	4	20	152.4	73
ANSI 3" 300 lbs	31	210	127	8	23	168.3	73
ANSI 4" 150 lbs	26	229	157	8	20	190.5	73
ANSI 4" 300 lbs	34	254	157	8	23	200	73
JIS 10K-50	16	155	96	4	19	120	51
JIS 40K-50	26	165	105	8	19	130	51
JIS 10K-80	18	185	126	8	19	150	73
JIS 40K-80	32	210	140	8	23	170	73
JIS 10K-100	18	210	151	8	19	175	73
JIS 40K-100	36	250	165	8	25	205	73

SATRON VL Pressure Transmitter

BLV820

15.2.2013

Dimensional drawings (dimensions in mm)

Housing types H, T and M 165

Housing type N 195

[Atex transmitter code 1, +15]

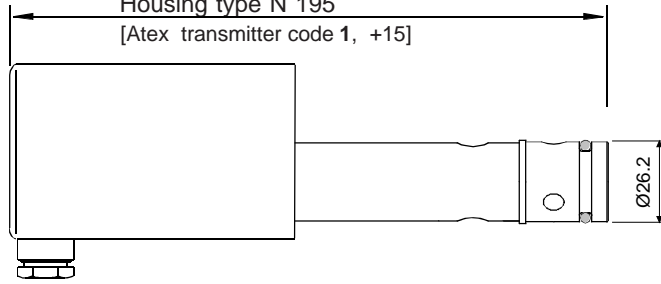

Process connection PA
- PMC 1"

BA - extension code	L
0	28,5
2	51
3	72
4	102

Housing types H, T and M 130

Housing type N 160

[Atex transmitter code 1, +15 and temperature code H, +40]

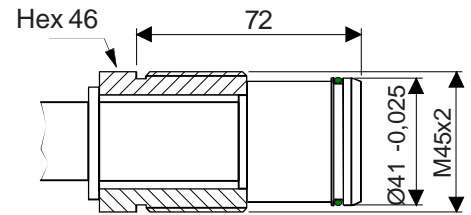
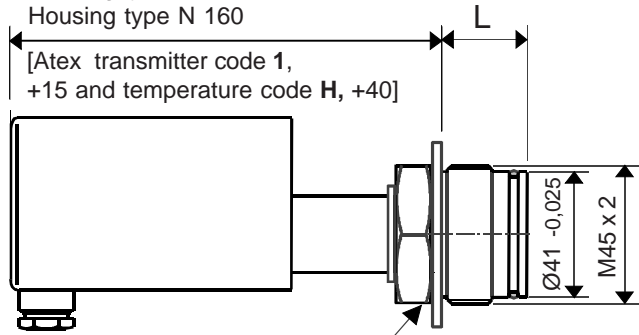

Process connection BB
- M45x2 with tapered

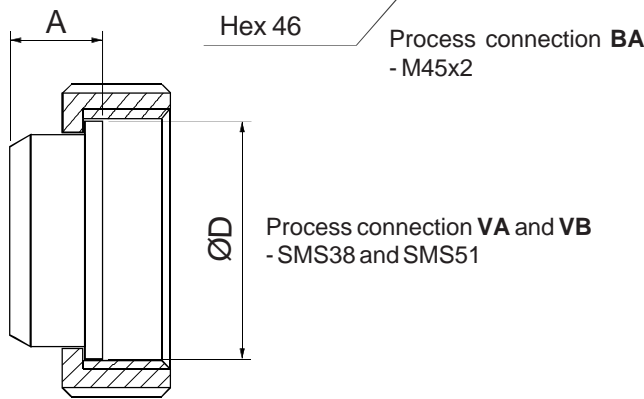

Process connection VA and VB
- SMS38 and SMS51

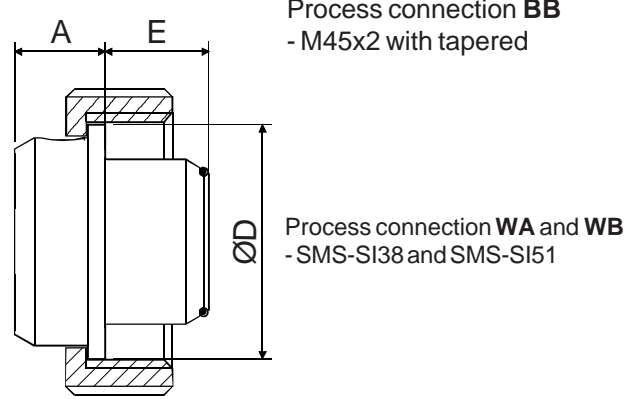

Process connection WA and WB
- SMS-SI38 and SMS-SI51

Size	Dimensions		Thread
	ØD	A	
38	54	21	Rd 60 x 1/6
51	64	23	Rd 70 x 1/6

Size	Dimensions			Thread
	ØD	A	E	
SI38	54	21	24	Rd 60 x 1/6
SI51	64	23	27	Rd 70 x 1/6

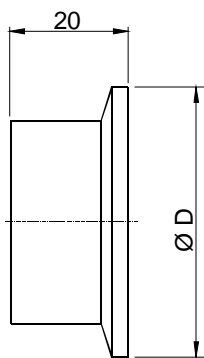

Process connection TA, TB and TC
- Tri-clamp DN38 ... 63.5

DN	ØD
38	50,5
51	64
63,5	77,5

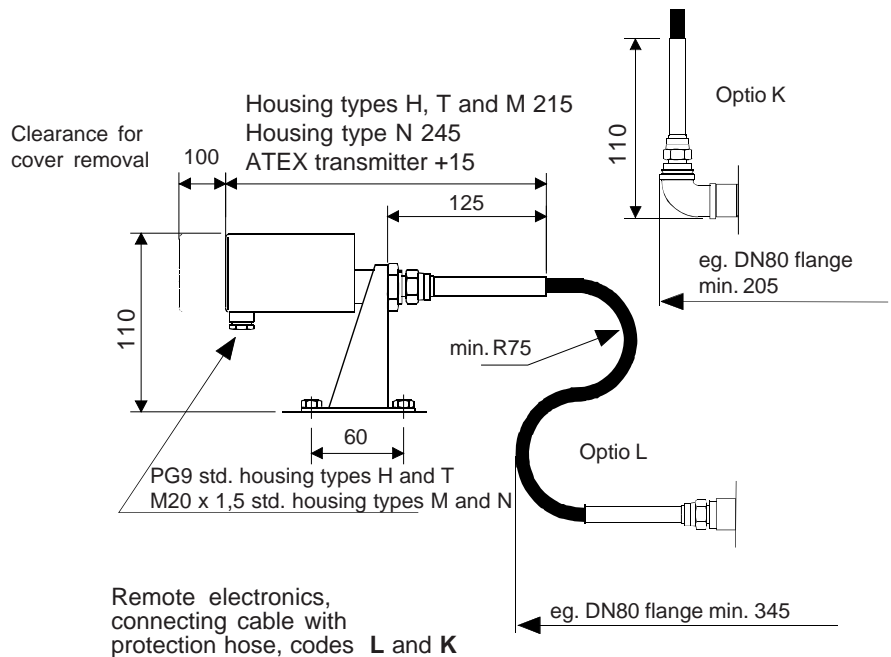

Remote electronics,
connecting cable with
protection hose, codes L and K

Dimensional drawings (dimensions in mm)

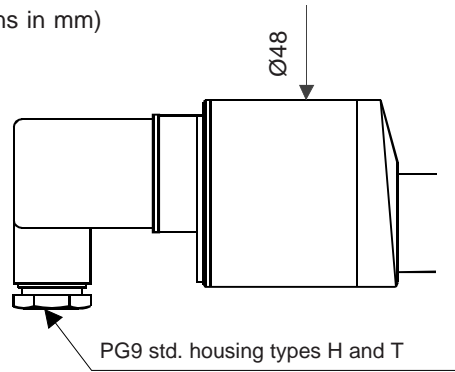

Housing with plug-connector, DIN 43650, codes H and T

PG9 std. housing types H and T

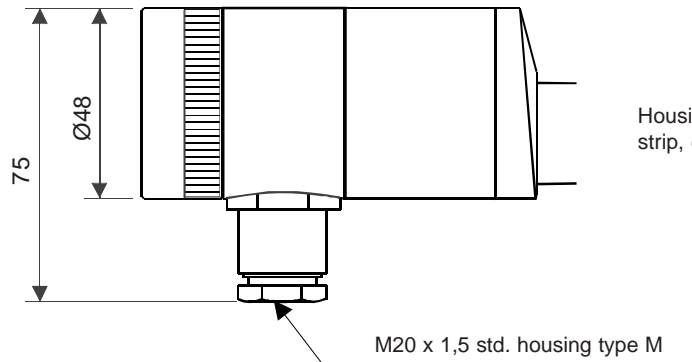

Housing with junction box/terminal strip, code M

M20 x 1,5 std. housing type M

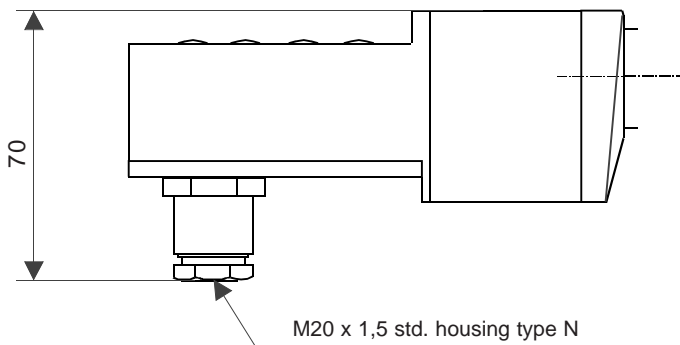

Housing with junction box/terminal strip, with display, code N

M20 x 1,5 std. housing type N

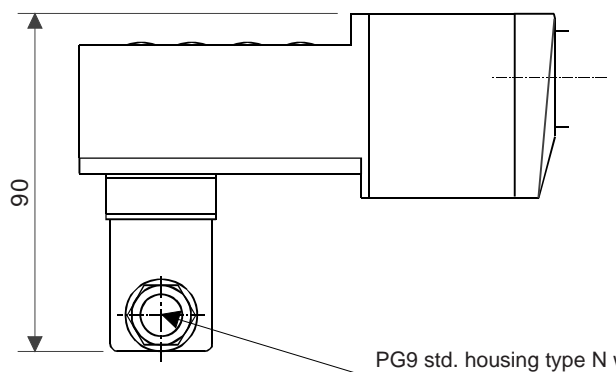

Housing with junction box/terminal strip, with display and plug-connector DIN 43650, code N- / P

PG9 std. housing type N with plug DIN 43650

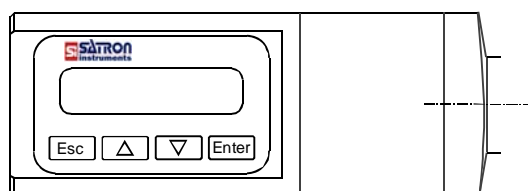

SATRON VL Pressure Transmitter

Selection Chart

Adjustability (±)	Span, min.	Span, max.	Measuring range
VL3	1.4kPa (14 mbar)	35 kPa (350 mbar)	-35...+35 kPa (-350...350 mbar)
VL4	4kPa (40 mbar)	100 kPa (1000 mbar)	-100...+100 kPa (-1000...1000 mbar)
VL5	10 kPa (100 mbar)	500 kPa (5000 mbar)	-100...+500 kPa (-1000...5000 mbar)
VLA5	10 kPa (100 mbar)	500 kPa (5000 mbar)	-100...+500 kPa (-1000...5000 mbar), abs.
VL6	0,03 MPa (0,3 bar)	3 MPa (30 bar)	-0.1...+3 MPa (-1...30 bar)
VLA6	0,03 MPa (0,3 bar)	3 MPa (30 bar)	0...+3 MPa (0...30 bar), abs.
VL7	1 MPa (10 bar)	15 MPa (150 bar)	0...+15 MPa (0...150 bar), abs.

Output	
S	4-20mA DC/HART® -protocol

Process connections			
DA	DN25 PN40 ISO 2084-1974	AA	ANSI 1" 150 lbs ANSI B16-5
DB	DN50 PN40 ISO 2084-1974	AB	ANSI 1" 300 lbs ANSI B16-5
DC	DN80 PN40 ISO 2084-1974	AC	ANSI 2" 150 lbs ANSI B16-5
DD	DN100 PN40 ISO 2084-1974	AD	ANSI 2" 300 lbs ANSI B16-5
JA	JIS 10K 50 JIS B 2220	AE	ANSI 3" 150 lbs ANSI B16-5
JB	JIS 40K 50 JIS B 2220	AF	ANSI 3" 300 lbs ANSI B16-5
JC	JIS 10K 80 JIS B 2220	AG	ANSI 4" 150 lbs ANSI B16-5
JD	JIS 40K 80 JIS B 2220	AH	ANSI 4" 300 lbs ANSI B16-5
JE	JIS 10K 100 JIS B 2220	TA	Tri-clamp DN38 PN40 ISO 2852
JF	JIS 40K 100 JIS B 2220	TB	Tri-clamp DN51 PN40 ISO 2852
TC	Tri-clamp DN63.5 PN40 ISO 2852	UA	Tuchenhagen DN50/40 (Varivent) PN40
PA	PMC 1" PN40	SA	Sandvik DN70 PN64
VA	SMS 38	VB	SMS 51
WA	SMS-SI 38 with 24 mm extension	WB	SMS-SI 51 with 27 mm extension
BA	M45x2 PN160	BB	M45x2 PN160

Extension length (mm)	(Flanged conn.)	(Sandvik-conn.)	
0	0	-	(not proc. conn. SA)
1	23	-	(only proc. conn. DA, DN25 PN40, max. +125°C)
2	51	54.5	(not proc. conn. BB, DA, PA, Tx, UA, Vx and Wx)
3	72	-	(only proc. conn. BA, in the Pasve BA mounting)
4	102	105	(not proc. conn. BB, DA, PA, Tx, UA, Vx and Wx)
6	152	156	(not proc. conn. BB, DA, PA, Tx, UA, Vx and Wx)

Wetted materials		Diaphragm		Extension or other wetted parts	
Code	Material	Code	Material	Code	Material
1	Nickel (*)	5	Tantalum	2	AISI316L
2	AISI316L	6	Titanium Gr2 (*)	3	Hast.C 276
3	Hast.C 276	8	Duplex (**)	8	Duplex (EN1.4462)

Fill fluid	S	G
	Silicone oil	Inert oil

Housing type	
H	Housing with PLUG-connector, DIN43650, no display, inlet PG9
T	Housing with PLUG-connector with manual adjust, DIN43650, no display, inlet PG9, (no ATEX)
M	Housing with junction box/terminal strip, no display, inlet M20x1,5
N	Housing with junction box/terminal strip, with display, inlet M20x1,5

Explosion proof	
0	No explosion proof classification
1	Atex Intrinsic Safety,  II 1 GD T135°C (***)

Temperature effect on -30°C to +80°C range, % per max. span	
G	±0,5%
E	±0,15%

Temperature effect on +20°C to +70°C range, % per max. span	
S	±0.08% (only process connections BA and DA)

Temperature effect on 0°C to +200°C range, % per max. span	
H	±1% (not possible process connections DA1, TA, TB and TC)

0	No coupling	2	AISI316L
A	With coupling	3	Hast.C276
		8	Duplex (1.4462)

Special size of electrical inlet		
N	1/2 NPT	G Pg13.5
P	Plug DIN 43650	

Special features

Special electronics (specify only if housing connected with hose to sensing element)

- connecting cable with protection hose

L Hose protected with PTFE/AISI316 braiding, straight

K Hose protected with PTFE/AISI316 braiding, angle of 90°

Length of cable between sensing element and housing
(specify only if housing connected with cable to sensing element)

2 2 m cable 3 3 m cable etc. (max. 10 m)

Mounting parts for remote electronics for Ø51 mm tube

0 No mounting parts 1 Mounting parts

Documentation

Calibration Certificate AE English

Installation and Operating Instructions IE English IF Finnish

Material Certificates

0 No material certificate

MC1 Raw materials certificate without appendices, in accordance with SFS-EN 10204-2.1 (DIN 50049-2.1) standard

MC2 Raw materials certificate for wetted parts with appendices, in accordance with SFS-EN 10204-2.2 (DIN 50049-2.2) standard

MC3 Raw materials certificate for wetted parts with appendices, in accordance with SFS-EN 10204-3.1B (DIN 50049-3.1B) standard

SMS-SI couplings :

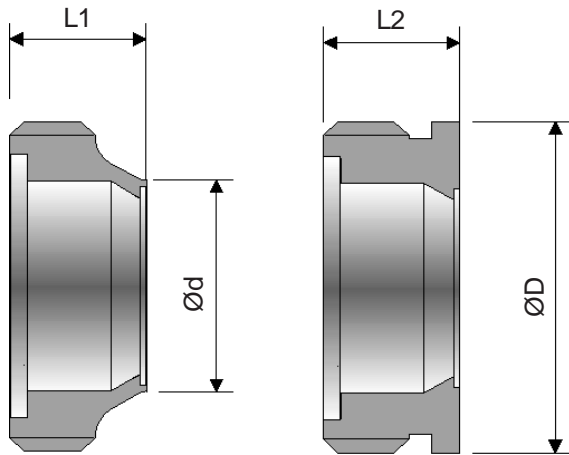

for pipe

for vessel

Size	Dimensions				Thread
	L1	Ød	L2	ØD	
38	27	38,5	24	60	Rd 60 x 1/6
51	30	51	25	70	Rd 70 x 1/6

Coupling M45x2 with adjust, for process connection BA, order code M1050459

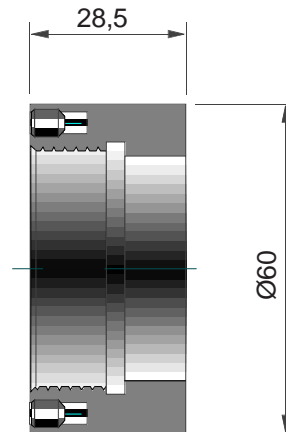

Pasve BA working position:

For process connections BA3 and BB

1. Transmitter in measuring
2. Transmitter can be checked, changed, calibrated or the transmitter diaphragm can be flushed

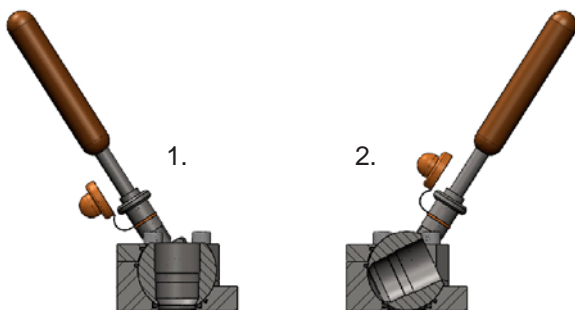

Coupling BB M45x2, for process connection BB, order code M1050474 (Welding assistant, code M1050473)

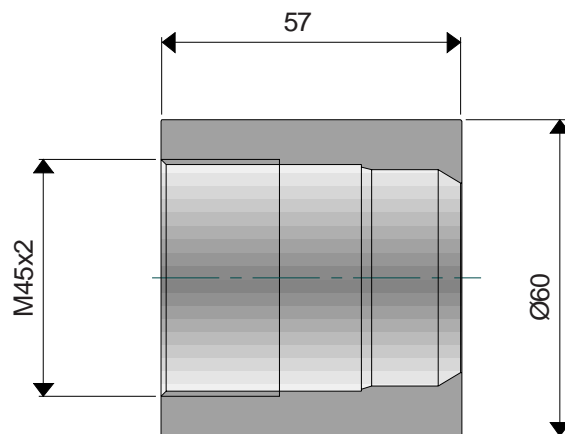

(*) = only with flange
 (**) = not for range 3 with process connection code PA
 (***) = Housing H and N : II 2 GD T135°C



Satron Instruments Inc., P.O.Box 22, FI-33901 Tampere, Finland
 Tel. +358 207 464 800, Telefax +358 207 464 801, www.satron.com

We reserve the right for technical modifications without prior notice.
 HART® is a registered trademark of HART Communication Foundation.
 Viton® is the registered trademark of DuPont Down Elastomers.
 Hastelloy® is the registered trademark of Haynes International.
 Teflon® is the registered trademark of E.I. du Pont de Nemours & Co

