

SATRON VO Turbidity and solids content sensor

SATRON VO turbidity and solids content analyzer is suitable for the measurement of different liquids. Savings can be obtained by using SATRON VO analyzer in process industries, e.g. the use of clean water can be minimized, the time used for the cleaning (CIP) will be shortened, the use of the end product (in dairy applications: milk) and the use of cleaning materials needed in the process can be optimized. The transmitter communicates digitally using the HART® protocol.



TECHNICAL SPECIFICATIONS

Measuring range and span

See Selection Chart.

Zero and Span adjustment

Zero elevation: Calibrated span is freely selectable on the specified range depending from the desired option. This can be made by using keyboard (display option) or HART®275/375 communicator.

Damping

- Time constant is continuously adjustable 0.01 to 60 s.

Repeatability

- 0.1% from maximum span.

Temperature limits

Ambient: -30 to +80 °C
Process: 0 to +100 °C / +140 °C (VOF)
-5 to +100 °C / +140 °C (VOM & VOD)
Shipping and storage: -40 to +80 °C.

Output 3-wire (3W), 4-20 mA

Supply voltage

Nominal 24 VDC, (21,6 - 27,6V)

Humidity limits 0-100 % RH

EMC directive 2004/108/EC

- EN 61326-1:2005

CONSTRUCTION

Materials:

Sensing element ¹⁾: AISI316L, Duplex (EN. 1.4462), Hast. C276/C22, or Titanium Gr2.

Surface quality: Polished Ra <0,8µm

Lens: quartz glass, Safir glass or PC plastic

Coupling ¹⁾: AISI316L, Duplex (EN 1.4462), Hast.C276 or Titanium Gr2

Other sensing element materials: AISI316, SIS 2343.

Pressure class:

- PN40
- Test pressure -1 to 30 bar

Housing with display,

codes **NOS & NOT:**

Housing: AISI303/316, Seals: Nitrile-rubber and Viton®, Nameplates: Polyester

Housing with M12 connector, code

HOT: Housing: AISI303/316, Seals:

Viton® and NBR.

Housing with PLUG DIN 43650 connector, code **HOS:**

Housing: AISI303/316, Seals: Viton® and NBR.

PLUG connector: PA6-GF30 jacket, Silicone rubber seal, AISI316 retaining screw.

Connection hose between sensing element and housing

Codes **L** and **R** :

PUR signal cable or hose protected with PTFE/AISI316 braiding

Calibration

For customer-specified range with minimum damping. (If range is not specified, transmitter is calibrated for maximum range.)

Electrical connections

Housing with PLUG connector, code **HOS:**

Connector type DIN 43650 model AF; Pg9 gland for cable; wire cross-section 0.5 to 1.5 mm².

Housing with M12 connector, code **HOT:** M12 plug connector

Housing with display, code **NOS:**

Connector type DIN 43650 model AF; Pg9 gland for cable; wire cross-section 0.5 to 1.5 mm².

Housing with display, code **NOT:**

M12 plug connector

I/O-connections

bout1-3

Relay, grounding contact

Maximum voltage 35 V

Maximum current 50 mA

Maximum leakage current 10 µA

bin1-3

NC (no connection) OFF

0...2 V ON

Minimum values for switch in use

Voltage 16 V

Current 4 mA

Leakage current 1 mA

Current output1

Range 3.5...23 mA

Maximum load 600 Ω

Factory setting 4...20 mA

Current output2

Internal power supply

Current output 2 has same ground as binary IO

Maximum load 400 Ω

Range 3.5...23 mA

Factory setting 4...20 mA

External power supply

Current output 2 is galvanically isolated

Maximum supply voltage 35 VDC

Range 3.5...23 mA

Factory setting 4...20 mA

Maximum load, See picture below

Maximum isolation voltage 100 VDC

Process connections

- With G1 connecting thread

- Tri-Clamp 25/38 and 40/51

Protection class: See Selection chart.

Weight

Housing with PLUG DIN43650

connector (**HOT**): 0.9 kg

Housing with M12

connector (**HOS**): 0.9 kg

Housing with display

(**NOS & NOT**): 1.3 kg

Remote Housing (**L**): 2.5 kg

Remote sensor (**R**): 2.5 kg

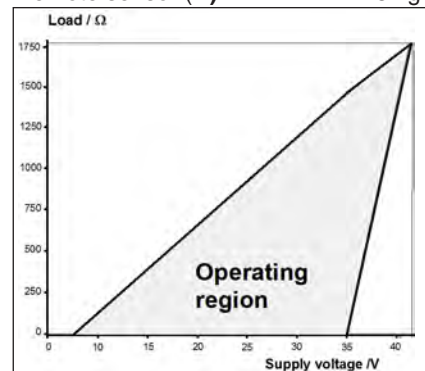

Min. load using HART®-communication 250 R

R max = $\frac{\text{Supply voltage} - 5 \text{ V}}{I \text{ max}}$

I max = 20,5 mA

I max = 22,5 mA

(when the alarm current 22,5 mA is on)

Current output 2

External power supply

¹⁾ Parts in contact with process medium

Dimensions and Housing types VOM

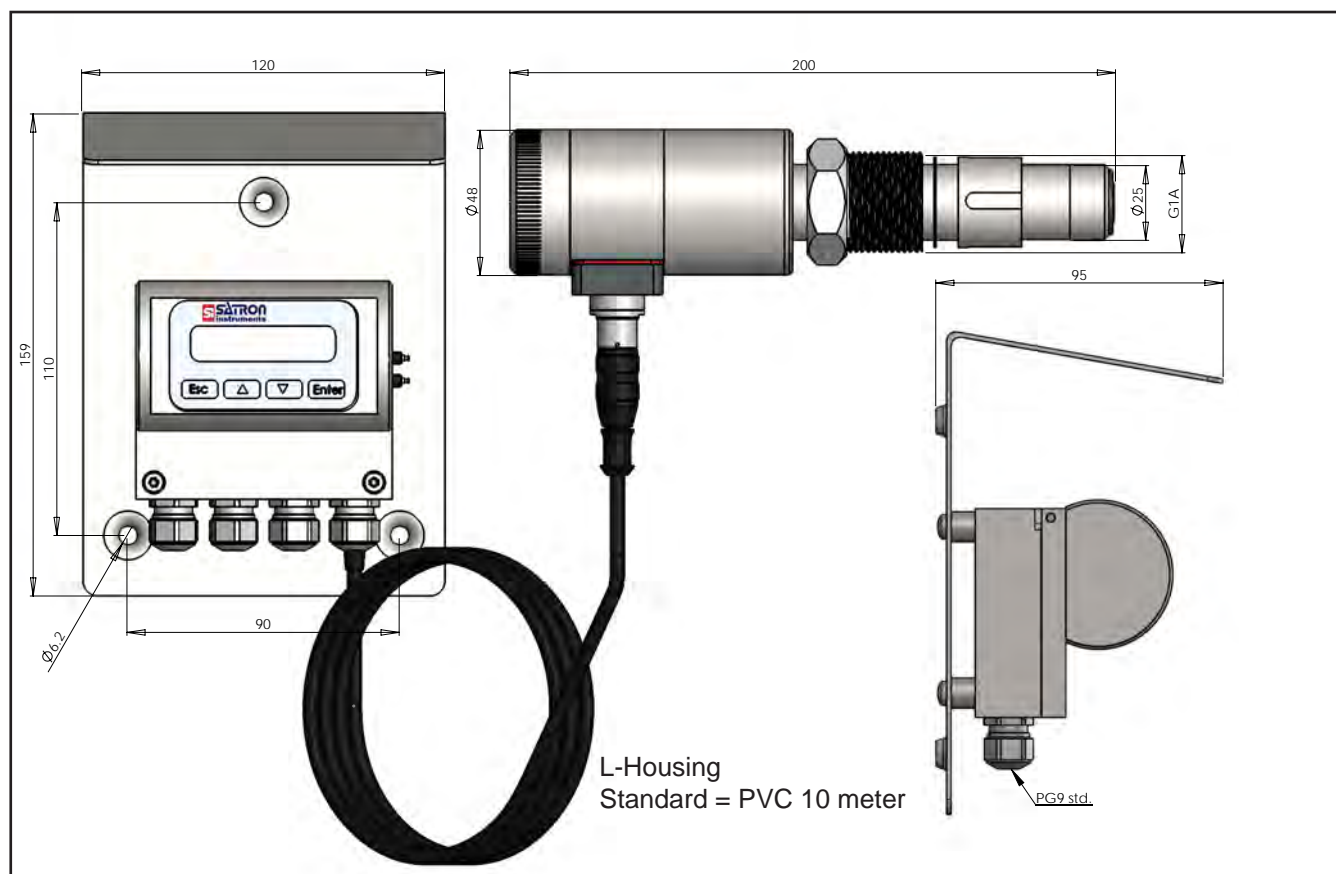
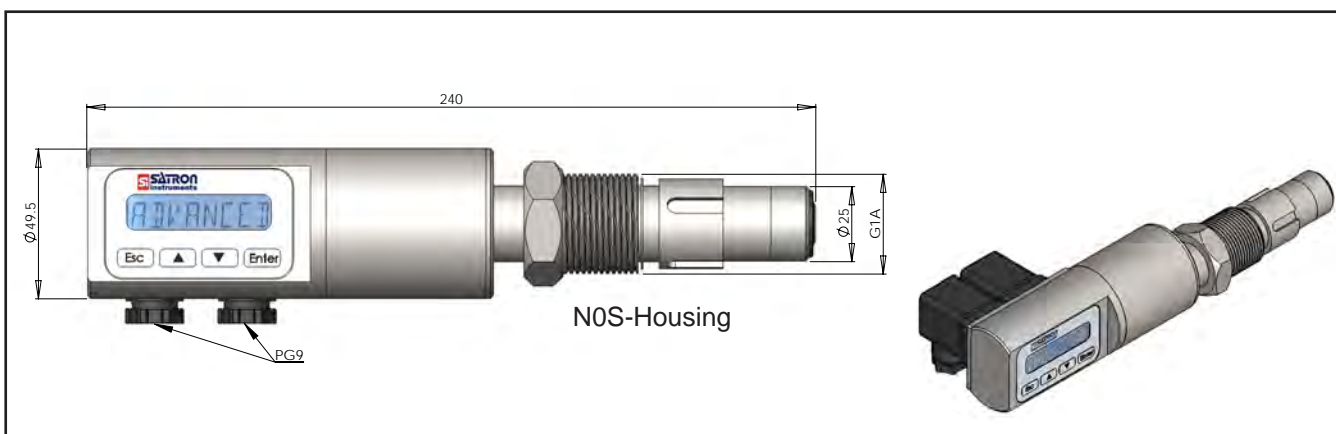
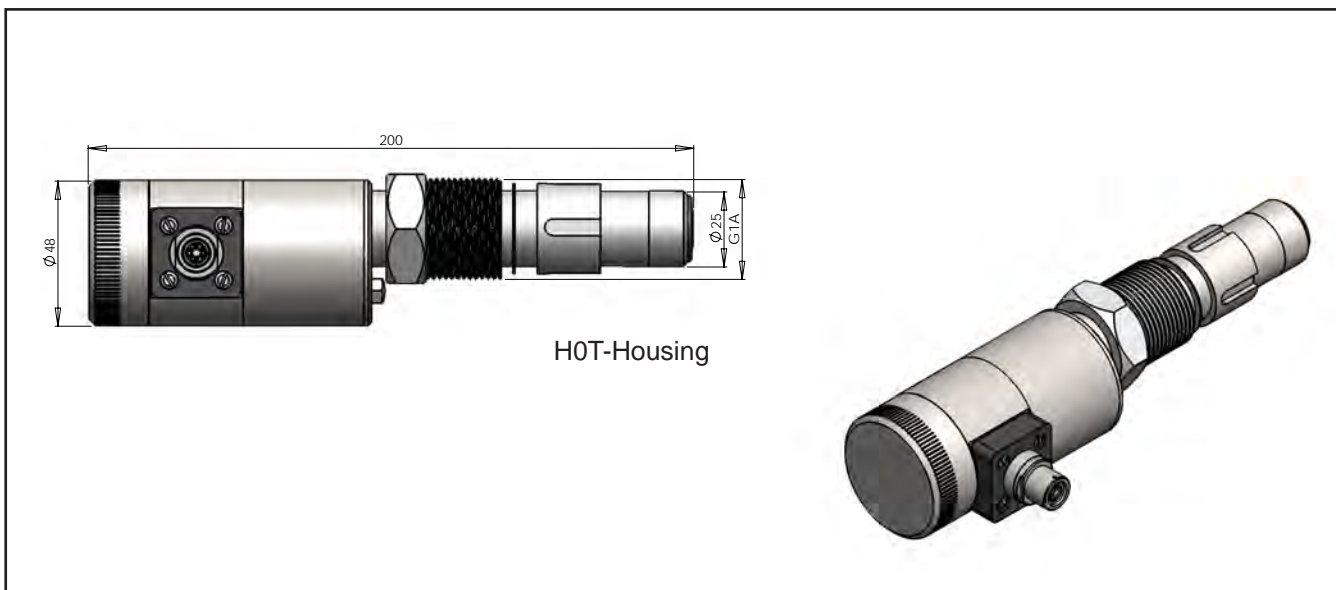

SATRON VO Turbidity and solids content sensor

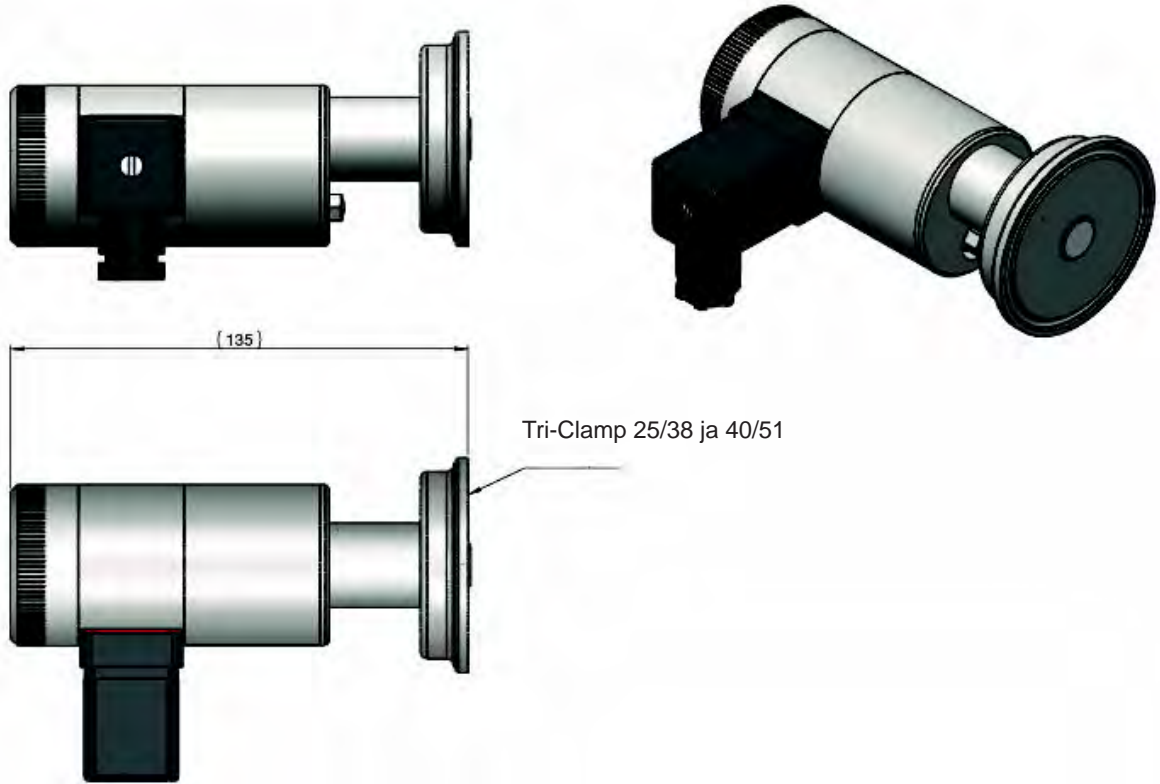

VOM with Tri-Clamp process connections, codes TA and TB

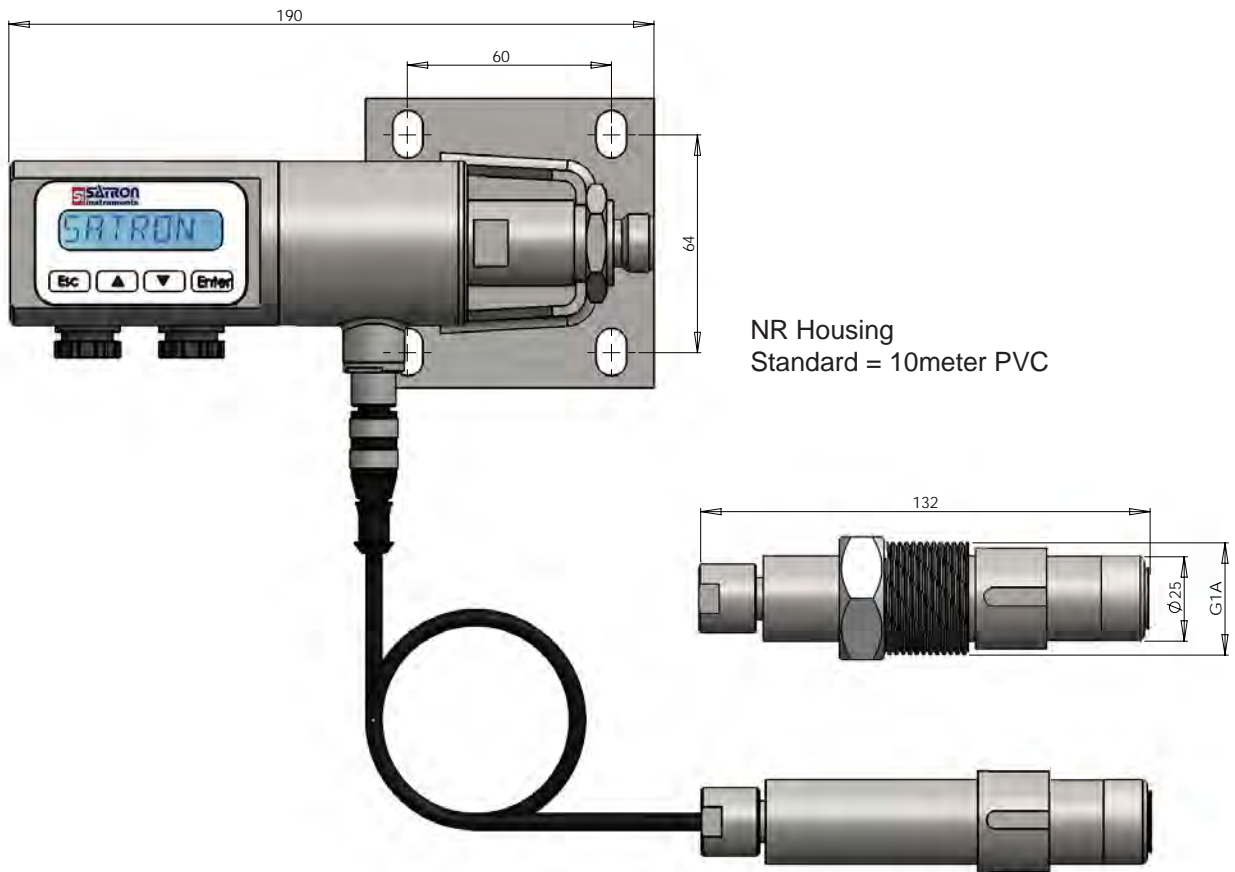

VOM with remote sensor, housing type code R

Dimensions and housing type VOF

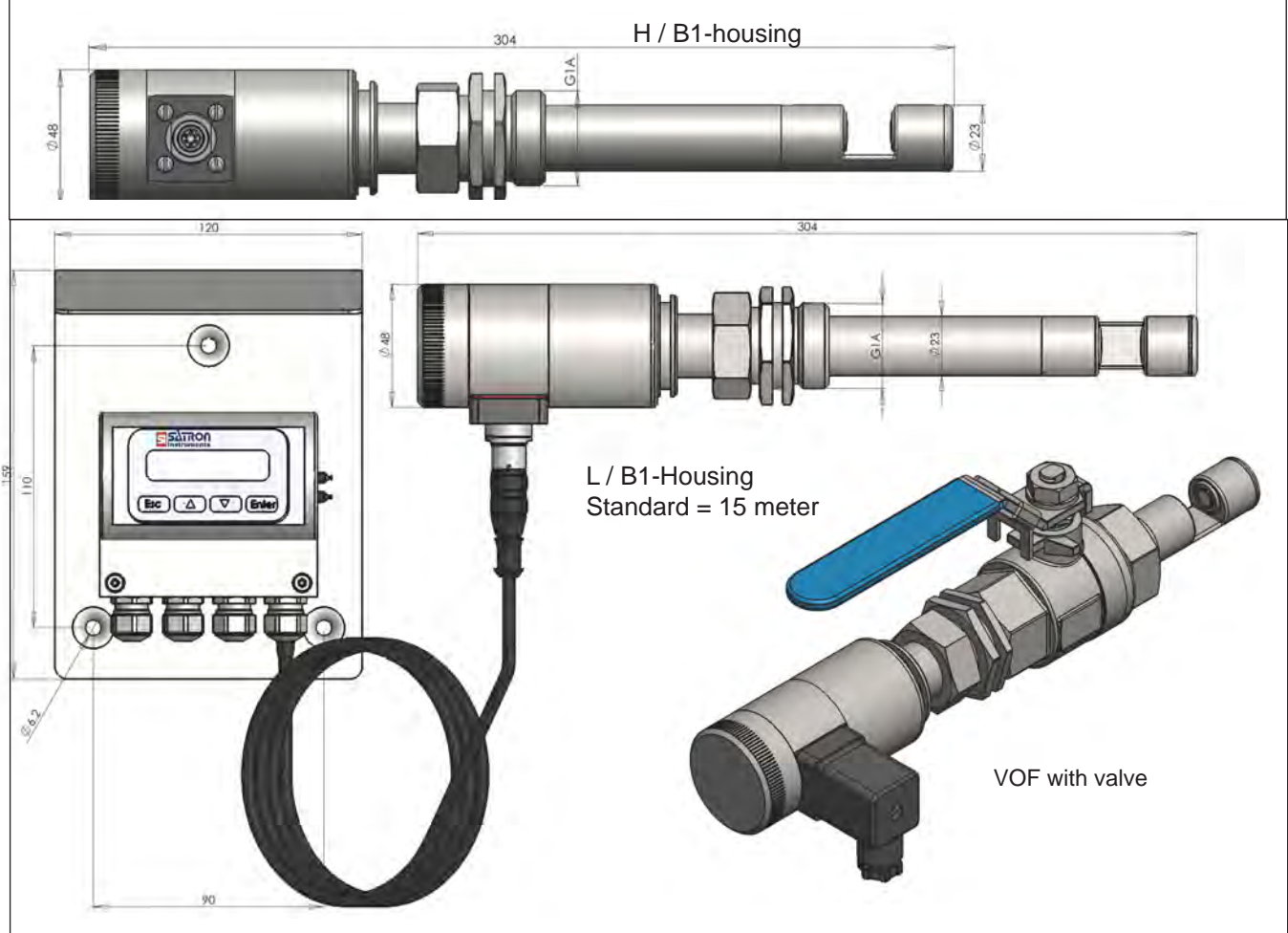

Dimensions and housing type VOD

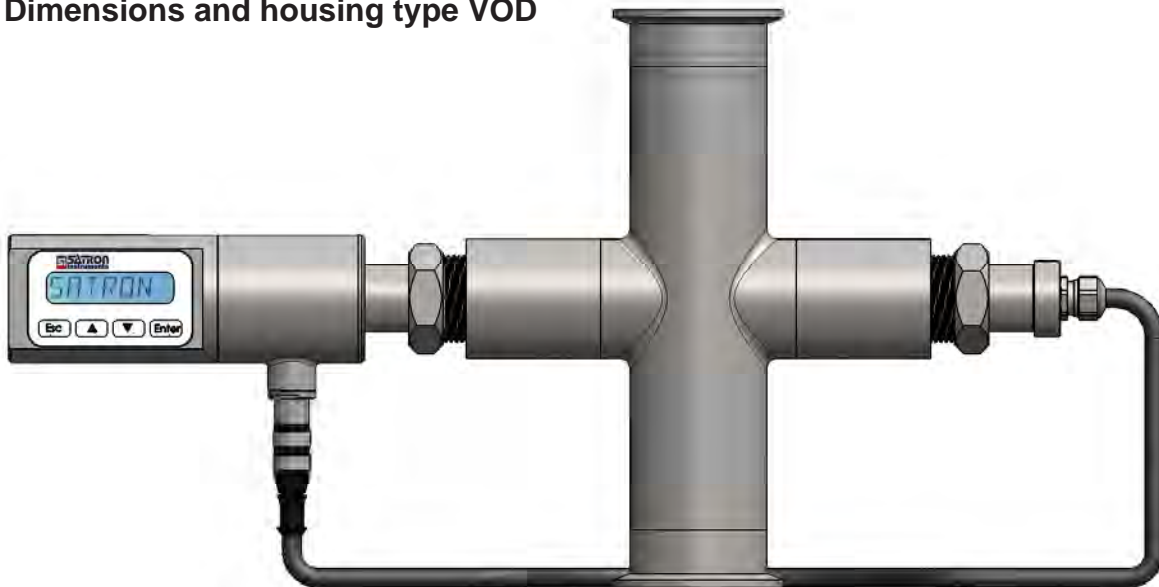

For easy installation the VOD is standard equipped with Tuchenhagen Type N but is available with many different process connections. The process pipe is NOT included.

Contact Satron for other possibilities, the picture above is a VOD equipped with G1" process connection, and a pipe with 51 Tri-clamp.

Instructions and spare parts that are according and within the 3-A appliance



Welding the coupling

These instructions apply to hygienic welded couplings; welding the G1 standard coupling is described here as an example.

- Place the coupling in the mounting hole as shown in Fig. 1-4. Make sure the leakage detection port is down. Then weld with several runs so to prevent the coupling's oval distortion and tightness problems. The inside welding must be cleaned, and polished with an end result of Ra <0,8
- The analyzer must be **out of the coupling** while the coupling is welded. You can use the shut-off plug shown in Fig. 1-5 to shut the coupling. The plug protects the coupling's sealing face and permits the starting of the process without the transmitter.
- It is always recommendable to use the welding assistant (M1050450) while welding the coupling to prevent any distortions due to heat.
- Do not make weld grounding via any analyzer's body!

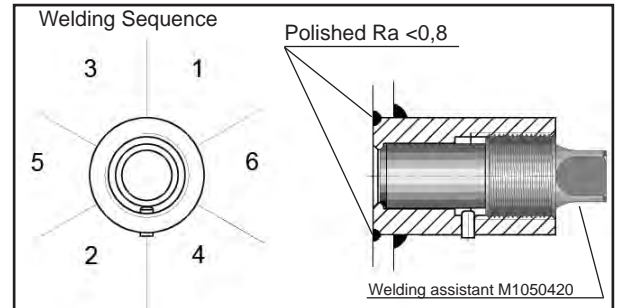

Mounting the analyzer on the coupling

Procedure

- Make sure that the coupling's sealing face is clean.
- Remove the orange protective plug from the analyzer head.
- Insert the analyzer **in a straight line** into the coupling, so that the guide groove on the transmitter aligns with the stop pin on the coupling. The analyzer settles into position when the groove and pin are aligned, and will be prevented from rotating in the coupling.

When inserting the analyzer, be careful not to damage the edge of the lens on the edges of the coupling or on the end of the stop pin!

- Lock the transmitter in position by screwing the hex nut fully home. Finger tightness is sufficient to tighten the sealing faces. However, we recommend final tightening with a tool to eliminate the effect of vibration and other such factors. Apply 60±20 Nm torque.

Do not use sealing tape etc. on threaded connection!

Spare parts

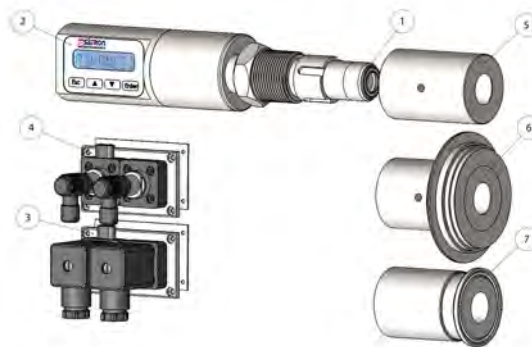

No.	Part name	Order code	Note
1	O-ring EPDM	80031720	3A 18-03 Class II (Do not exceed above 8% fat content).
1	O-ring FPM (Viton®)	80011720	3A 18-03 Class I
1	O-ring FFPM(Kalrez®)	80041717	3A 18-03 Class I
2	Sticker	T1325215	
3	Plug cover DIN43650	T1325003	
4	Plug cover M12	T1325005	
5	38/G1" Welding adapter	M1050577A	
5	45/G1" Welding adapter	M548101A	
6	Tuchenhagen / Varivent DN25	M1050090A	
6	Tuchenhagen / Varivent DN50	M1050091A	
6	Tuchenhagen / Varivent DN65,5	M1050092A	
7	Tri-clover 25/38 ISO2852	M1050206A	
7	Tri-clover 40/51 ISO2852	M1050222A	
7	Tri-clover 63.5 ISO2852	M1050224A	



Housing with display, code N

Keyboard :

- Esc = Press **Esc** move back towards the top of the main menu.
- ▲ = Use the **UP** arrow key to move up on the current menu level or to increase the selected parameter value.
- ▼ = Use the **DOWN** arrow key to move down on the current menu level or to decrease the selected parameter value.
- Enter = Press **ENTER** to move to a lower level in a menu or to accept a command or parameter value

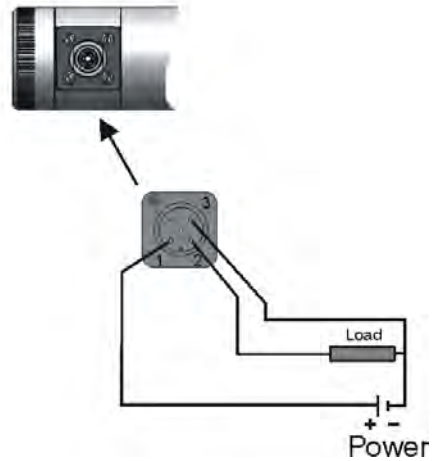

Wiring
Housing with M12-connector, code HT

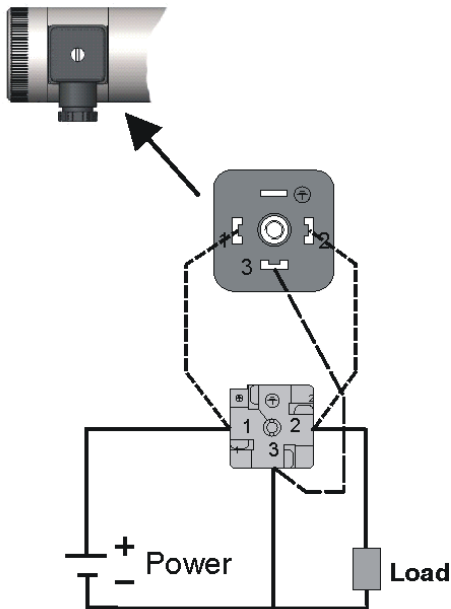

Wiring
Housing with PLUG DIN43650-connector, code HS

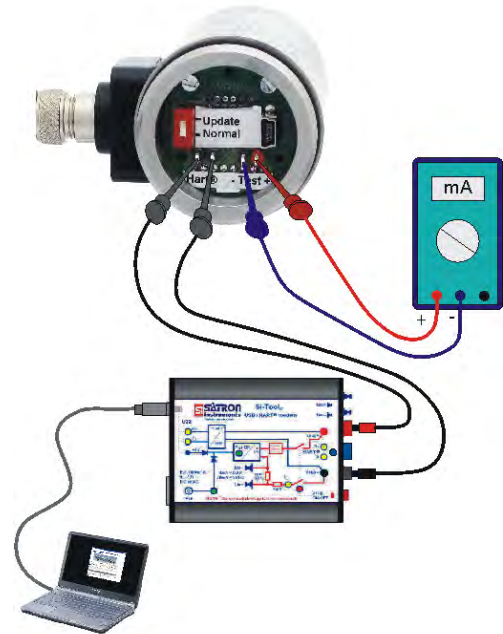

Wiring
Housing with PLUG DIN43650- and M12-connector, test connector box, code HT & HS

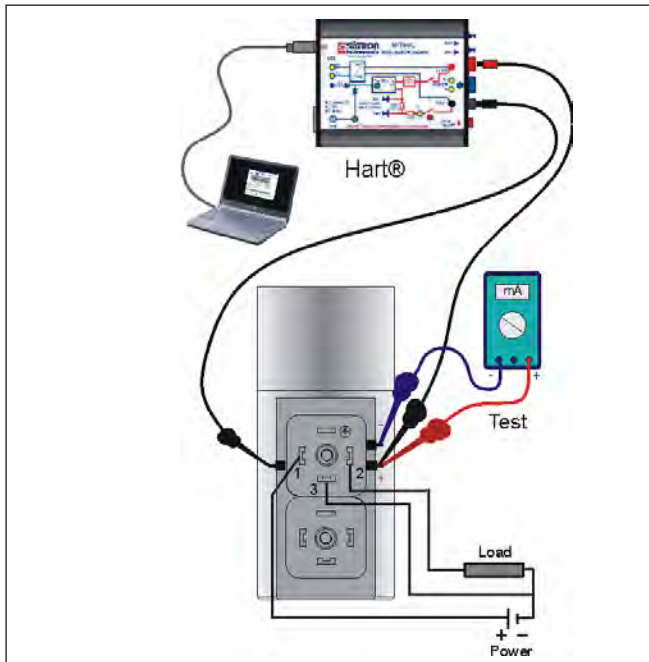

Wiring
Housing with display and PLUG DIN43650-connector,
code **NS**

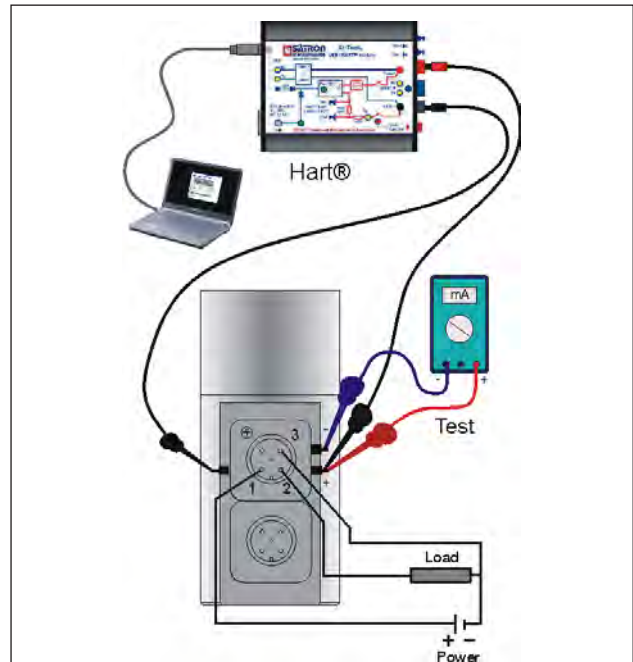

Wiring
Housing with display and M12-connector, code **NT**

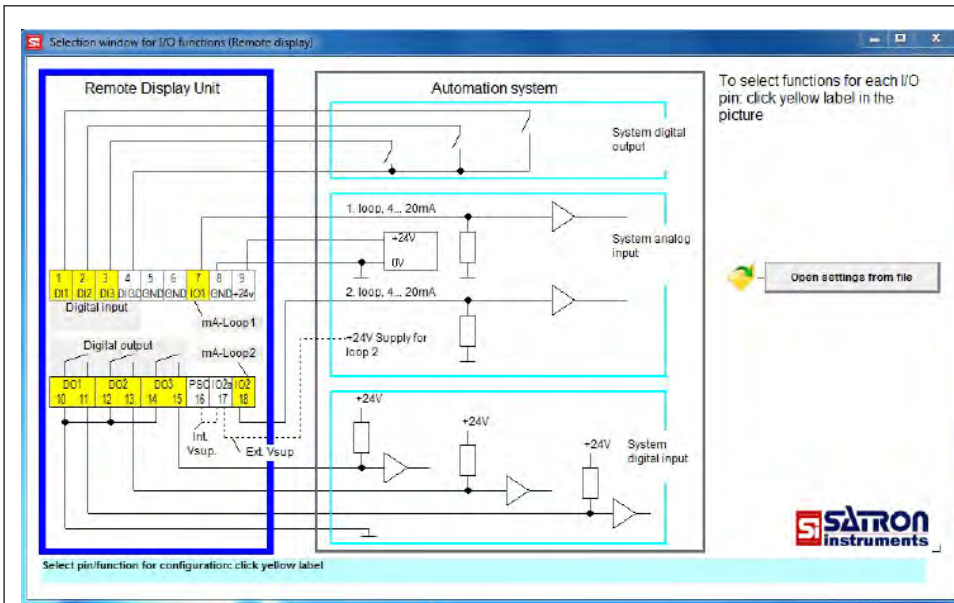

Wiring
Remote electronics housing with display, code **L**

Selection Chart

Adjustability		Span, min		Span, max				
VOM		1000 FTU		5000 FTU				
VOF^(*)		50 FTU		1500 FTU				
VOD		50 FTU		1500 FTU				
Process temperature limits	N	Normal version	-5...+100 °C (VOM & VOD), 0...+100 °C (VOF)					
	H^(**)	High temperature	-5...+140 °C (VOM & VOD), 0...+140°C (VOF)					
Output	S	4-20mA DC/HART® for use with 230VAC 50Hz						
	J	4-20mA DC/HART® for use with 110VAC 60Hz						
Material of wetted parts	Body		Lens	Seal	3A 18-03			
	2	AISI316L	2	Sapphire glass	1^(***) EPDM	Class II		
	3	Hast. C 276	4	Spinel	2 FPM (Viton®)	Class I		
	6	Titanium Gr2			3 FFPM (Kalrez®)	Class I		
	8	Duplex (EN 1.4462)						
	9	Peek						
Housing type	N	Housing with display and pushbuttons						
	H	Housing with, no display, (only one mA output)						
	L	Remote electronics housing with display						
Probe type	0	No remote probe						
	R	Remote measuring probe (not available with L housing), IP68						
Connection type	S	DIN43650 with PG9, IP66						
	T	M12, IP67						
	V	PG9 (always with L housing), IP66						
Cable Material	0	No VOD, L or R selected						
	1	PUR cable.						
	2^(*)	AISI316L braided PTFE hose.						
	3	Steel reinforced PUR hose.						
	4	PVC cable						
Cable length	0	No VOD or L, R option selected						
	1	5 M.	3	15 M. (PUR std.)	5	25 M.		
	2	10 M. (PVC std.)	4	20 M.		...		
Light source	2	365nm	4	540nm	6	640nm	8	950nm
	3	460nm	5	580nm	7	880nm		
Process connections								
G1	Standard G1A thread + Oring							
TA	Tri-Clamp 25/38 (ISO 2852)							
TB	Tri-Clamp 40/51 (ISO 2852)							
TN	Tuchenhagen "N" type DN50							
HX^(*)	Fixed mounting tube, (specify length)							
B1^(*)	G1A ball valve insertion. Extension 19cm diameter ø 24mm							
BX^(*)	G1A ball valve insertion. Extension by request diameter ø 24mm							



Documentation	
Calibration certificate	AE English
Installation and operating instructions IE English IF Finnish FR French	
Material certificates	
0	No material certificate
MC1	Raw material certificate without appendices, in accordance with SFS-EN 10204-2.1 (DIN 50049-2.1) standard
MC2	Raw material certificate for wetted parts, in accordance with SFS-EN 10204-2.2 (DIN 50049-2.2) standard
MC3	Raw material certificate for wetted parts, in accordance with SFS-EN 10204-3.1 B (DIN 50049-3.1 B) standard

* Not EHEDG certified & Not within the 3A approval
 ** Only in combination with Quartz, Sapphire lens and Kalrez Seals. And only 880nm
 *** Do not exceed above 8% fat content.

We reserve the right for technical modifications without prior notice.

HART is the registered trademark of HART Communication Foundation.
 Pasve is the registered trademark of Satron Instruments Inc.
 Hastelloy is the registered trademark of Haynes International.
 Viton is the registered trademark of DuPont Down Elastomer.
 3-A is a registered mark owned and administered by 3-A SSI.

