

Installation and Setting-Up Instructions Spare Parts List

Contents:

1 INSTALLATION

- 1.1 Mechanical installation
- 1.2 Electrical connections

2 SETTING UP

- 2.1 Using the 275 user interface
- 2.2 Setting up through HART® 275 user interface
- 2.3 Using the 375 user interface
- 2.4 Setting up through HART® 375 user interface
- 2.5 Setting up with Satron-pAdvisor Service Software
- 2.6 Setting up with local switches
- 2.7 Set-up calibration

3 CALIBRATION

- 3.1 Adjustability
- 3.2 Damping
- 3.3 Calibration examples

4 CONSTRUCTION AND OPERATION

5 PARTS LIST



DOCUMENTS

Technical Specifications: BLV810

Installation and Setting-Up Instructions: BLV810AV

We reserve the right for technical modifications without prior notice.
HART® is a registered trademark of HART Communication Foundation.
Hastelloy® is the registered trademark of Haynes International.
Viton® is the registered trademark of DuPont Down Elastomers.



Satron Instruments Inc.

P.O.Box 22, FIN-33901 Tampere, Finland
Tel.int. +358 207 464 800, Telefax +358 207 464 801
www.satron.com, info@satron.com

1 INSTALLATION

VV pressure transmitter is suitable for liquid level measurements in ground and rock tanks, and in open channels and ships' tanks.

Transmitters can also be used in corrosive conditions and to measure contaminating liquids.

1.1 Mechanical installation

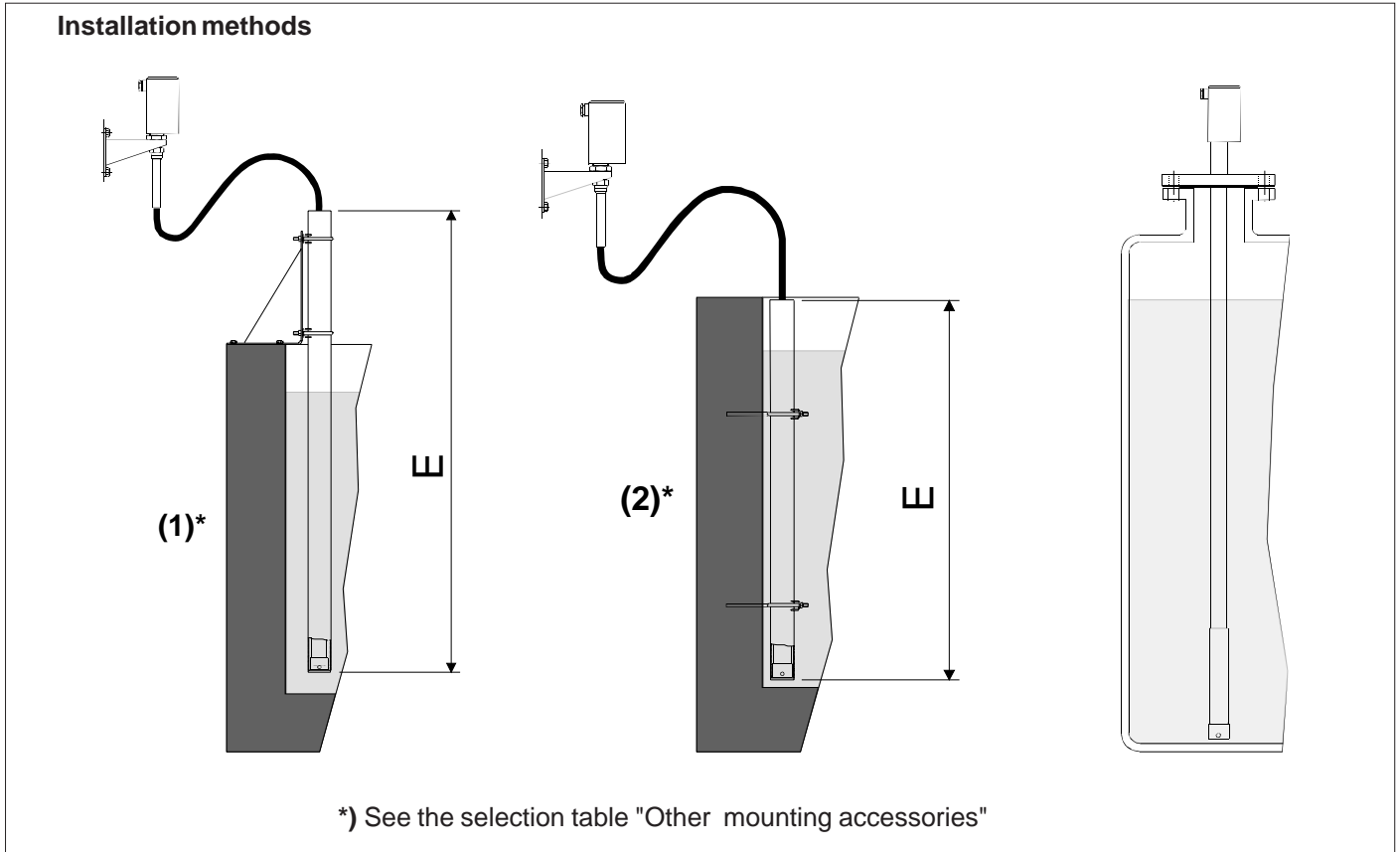

Figure 1-1 Installation methods

Mounting recommendations:

- Process connection direction: vertical
- Cable entry direction: horizontal
- Connector coupling direction, calibration direction:
 - types VVP and VVH: vertical
 - type VVF: vertical or horizontal
 - (equipment cabinet: vertical)

Other considerations:

- Equipment cabinet is recommended for extremely demanding conditions. The equipment cabinet can be provided with heating.
- Freezing of condensed water in reference pressure port must be prevented.
- The opening the rubber cap protecting the filter at the mouth of the reference pressure port must be turned in such direction that any liquid or other material that might block the filter is prevented from accumulating inside the protective cap.

Dimensional drawings (drawings in mm)

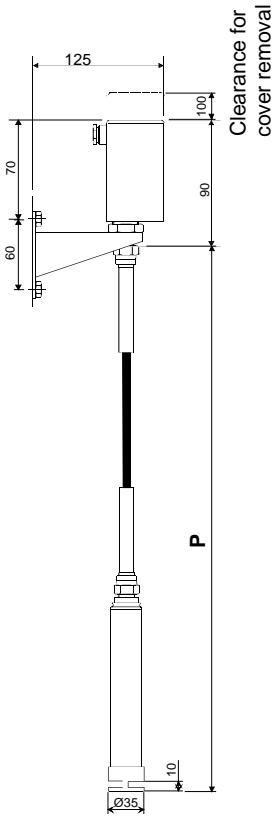

Type HVF

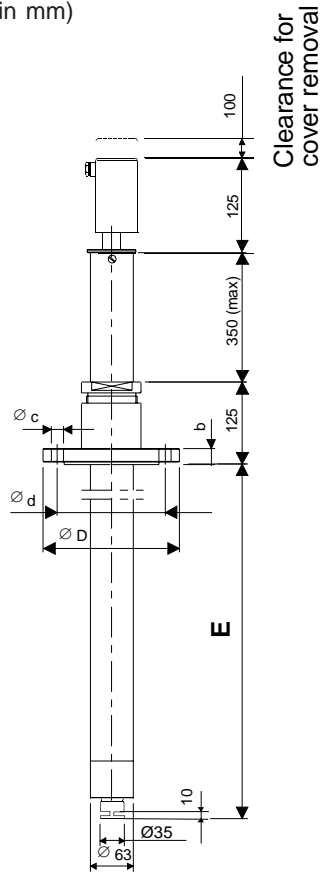

Type HVP
(housing H)

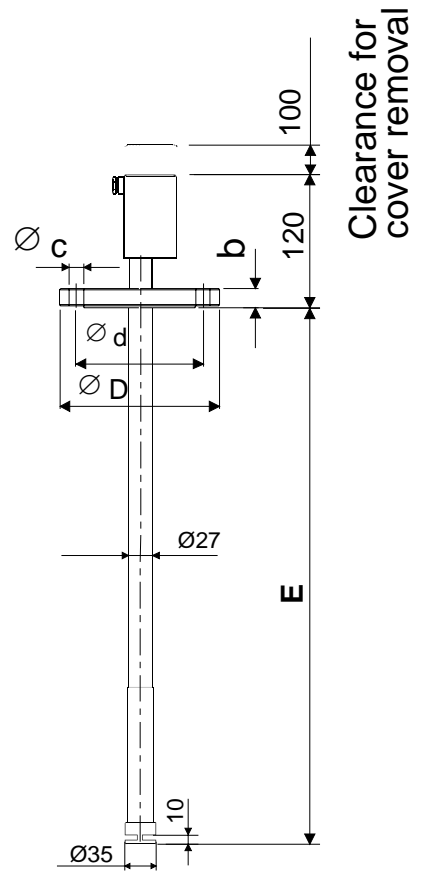

Type HVH
(housing H)

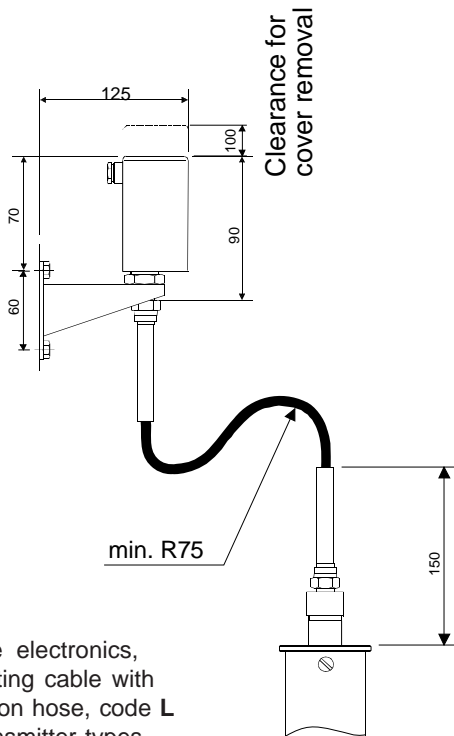

Remote electronics, connecting cable with protection hose, code L (for transmitter types VVP and VVH)

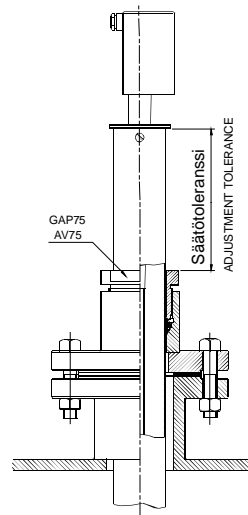

Flange mounting with adjustment facility, type VVP

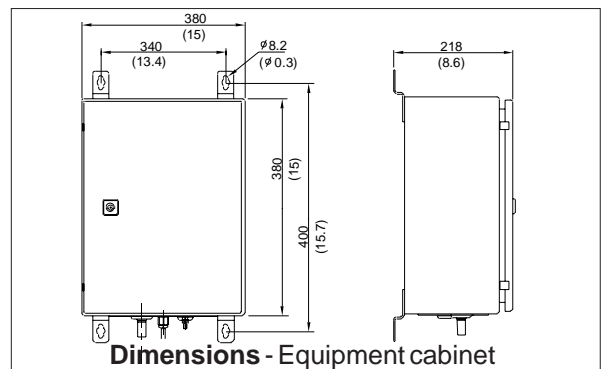

Dimensions - Equipment cabinet

Flange	Code	ØD	Ød	Øc	b
DN50 PN40	DB	165	125	4x8	20
DN80 PN40	DC	200	160	8x8	24
ANSI2"150lb	AC	152	120.6	4x20	23
ANSI2"300lb	AD	165	127	8x20	25
ANSI3"150lb	AE	191	152.4	4x20	26
ANSI3"300lb	AF	210	168.3	8x23	31

Type	P/m		E/m	
	min.	max.	min.	max.
VVF	1.0	20.0	-	-
VVP	-	-	1.0	5.5
VVH	-	-	1.0	5.5

Figure 1-2a Dimensional drawings

Dimensional drawings (dimensions in mm)

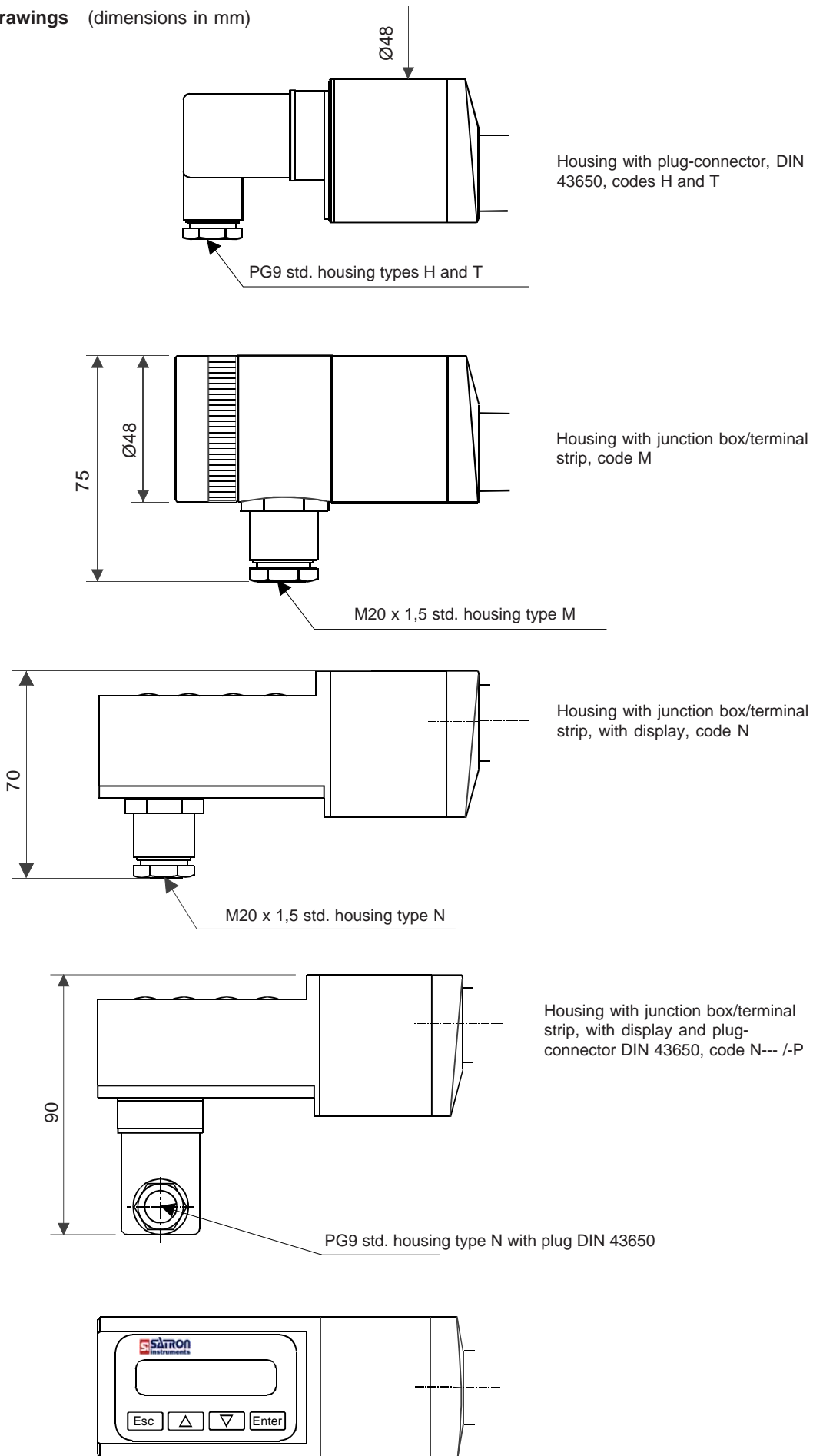

Figure 1-2b Dimensional drawings

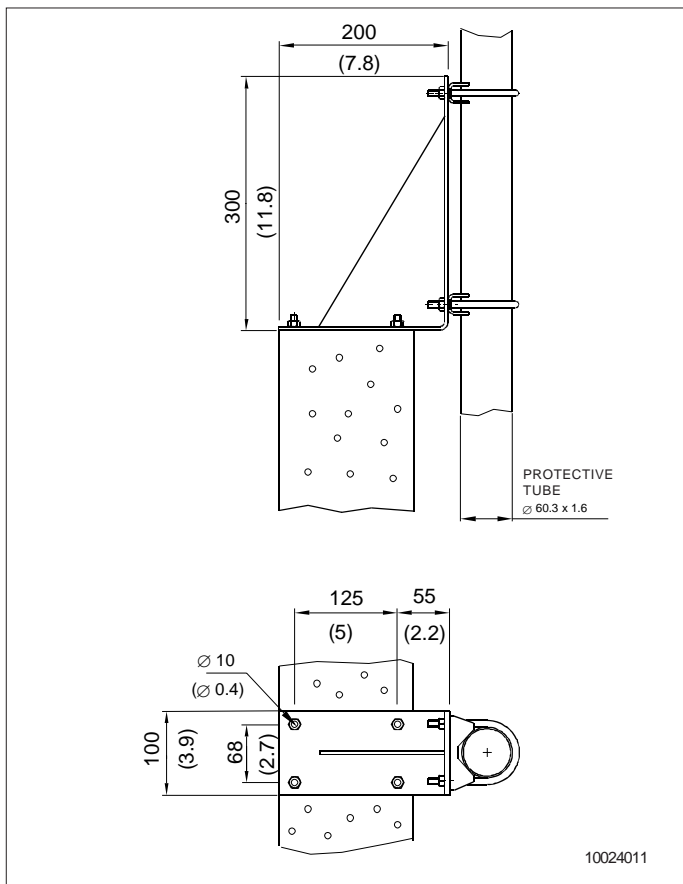

Figure 1-3
Clamp mounting on angle bracket
- mounting accessories code 1

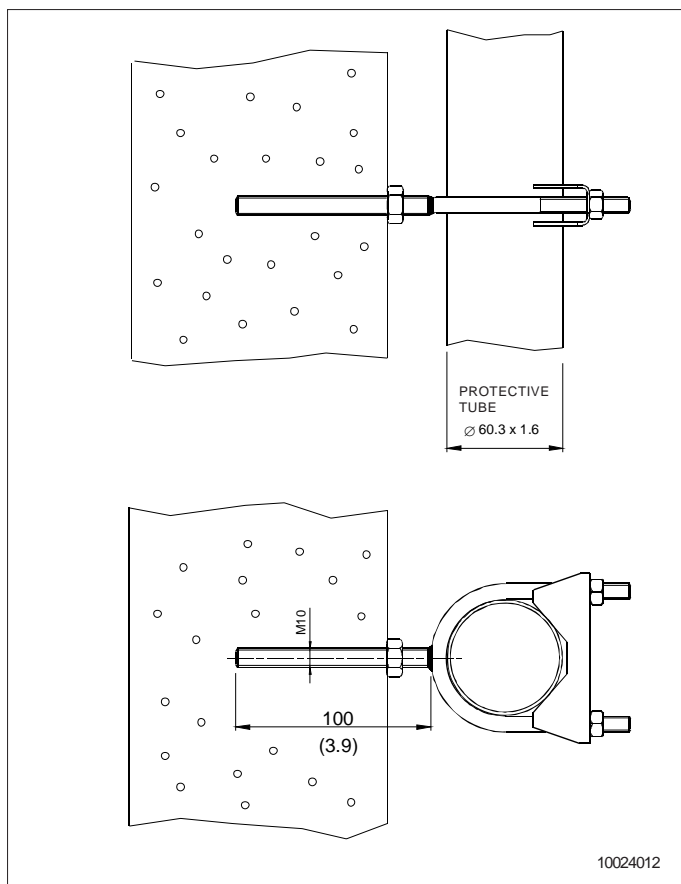

Figure 1-4
Clamp mounting on tank
- mounting accessories code 2

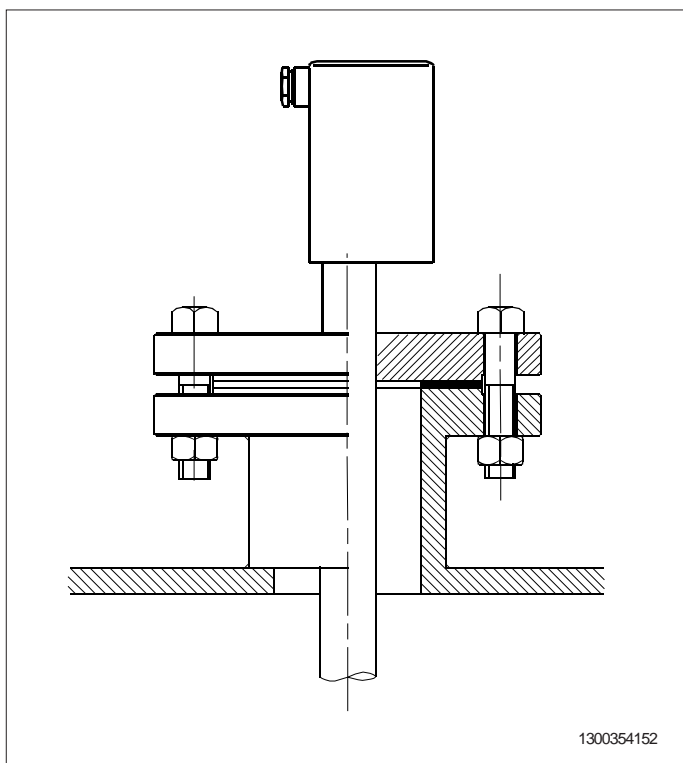

Figure 1-5
Flange mounting without adjustment facility
- type VVH

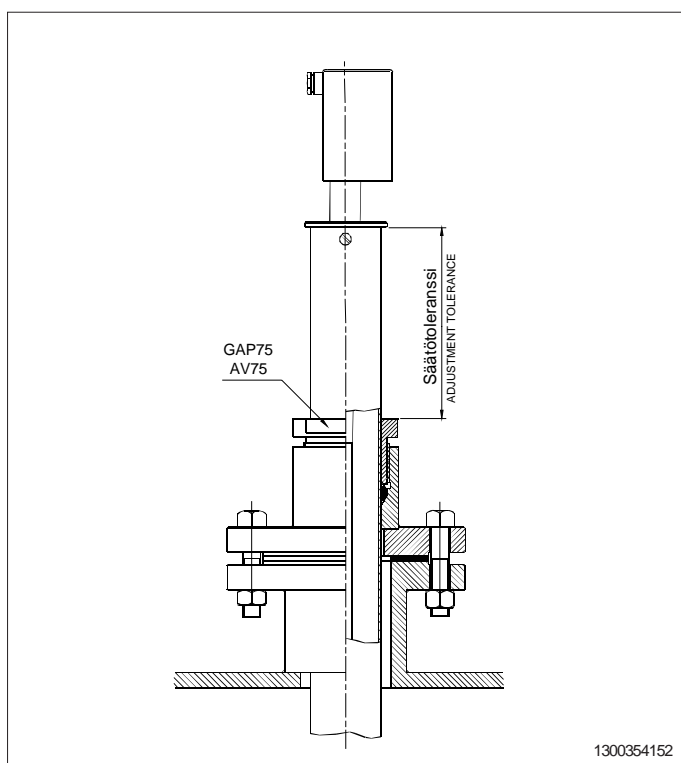

Figure 1-6
Flange mounting with adjustment facility
- type VVP

1.2 Electrical connections

Supply voltage and load of the transmitter according to the figure 1-8.

We recommend shielded twisted-pair cable as signal cable.

The signal cable should not be installed near high-voltage cables, large motors or frequency converters.

The shield of the cable is grounded at the power supply end or according to the recommendations of the manufacturer of the used control system.

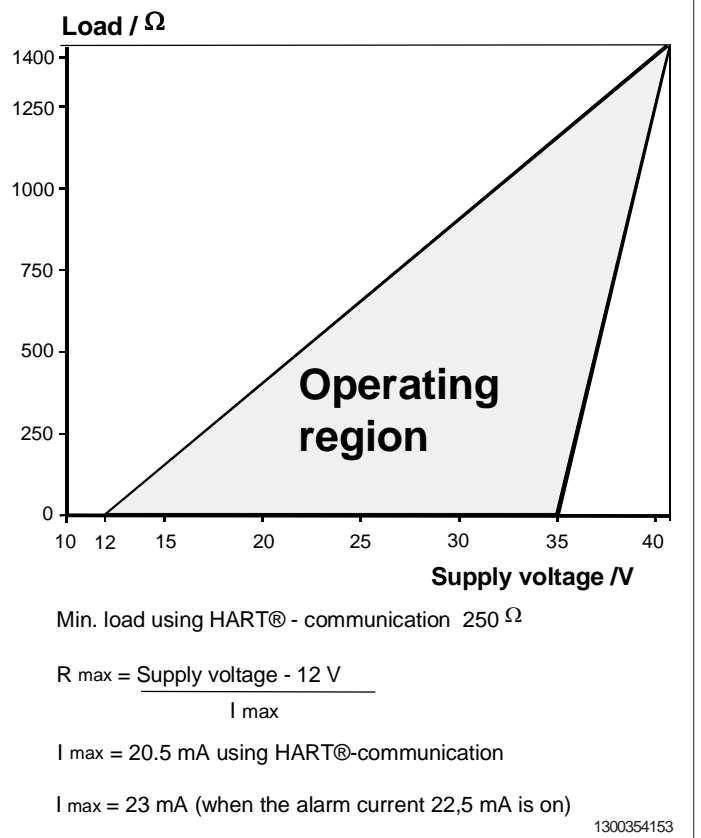
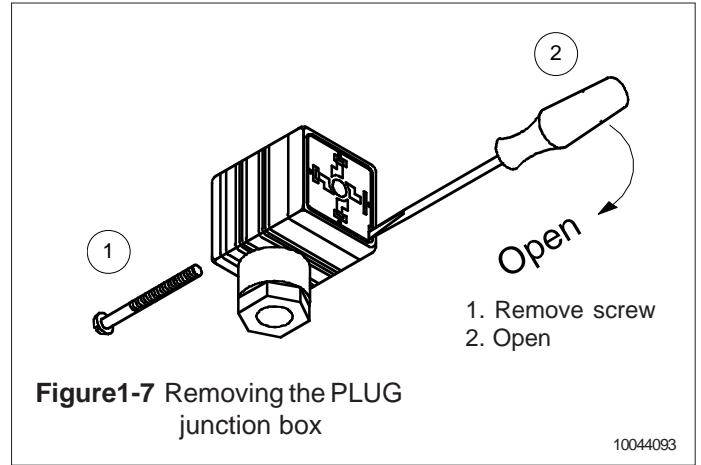
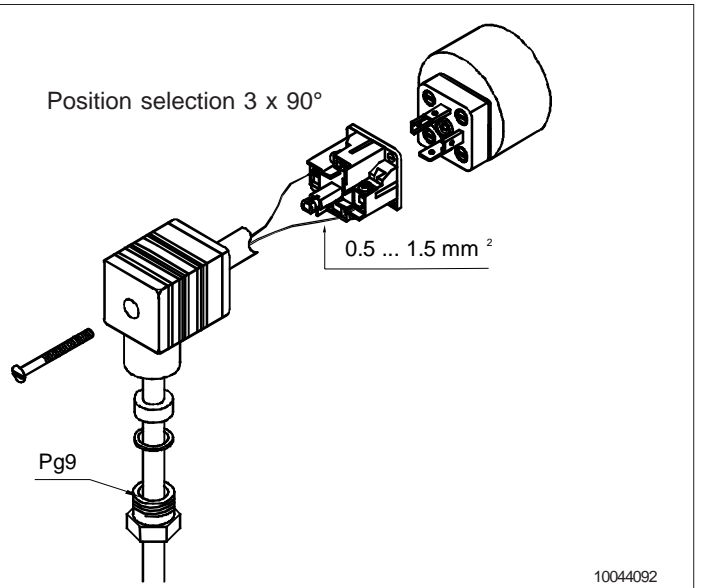
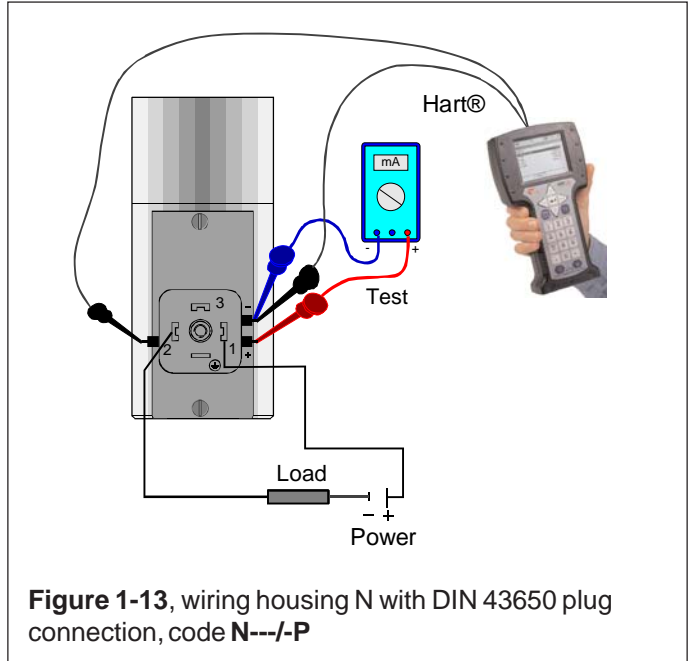
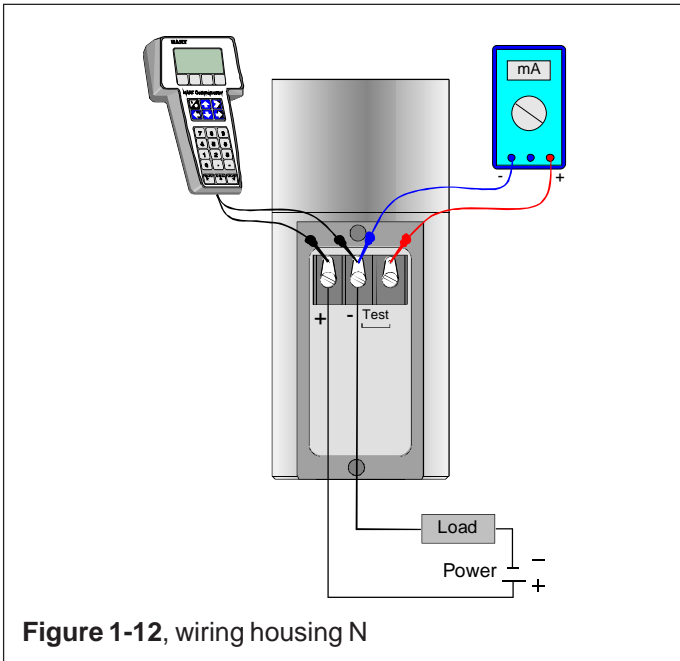
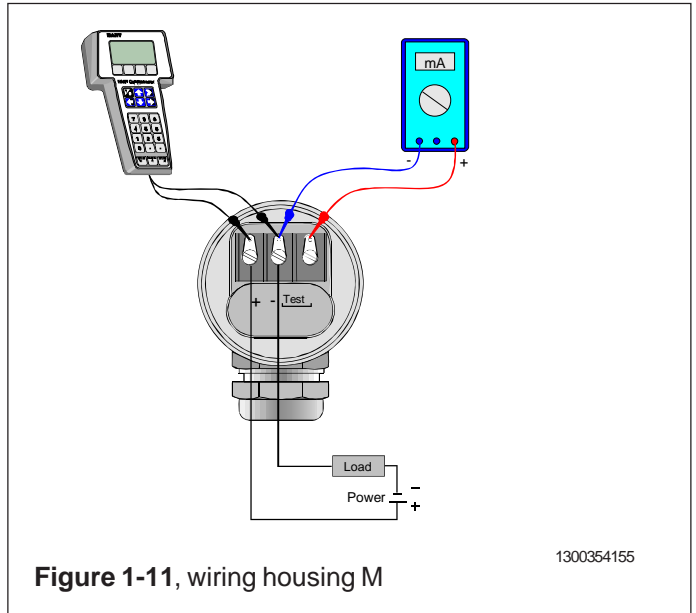
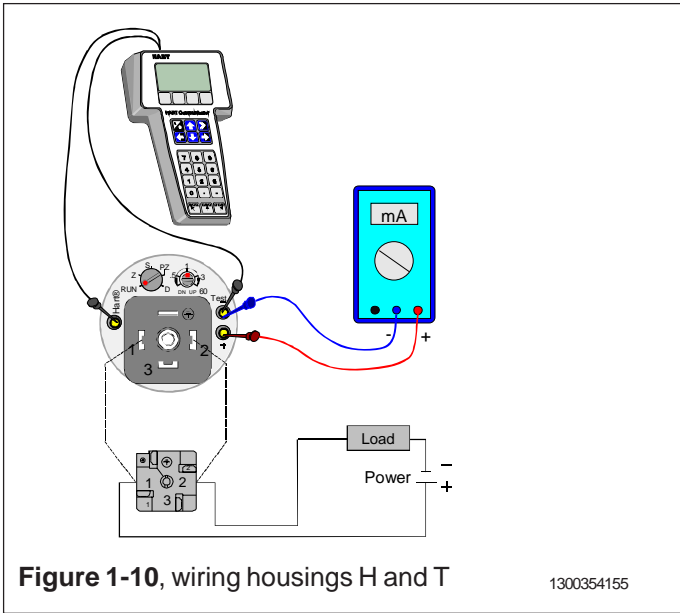

Figure 1-8 Supply voltage and load capacity





2 SETTING UP

Setting up is dependent on type of user interface and loaded description **VALMET** or **SATRON**. Also must be noted that when the older **VALMET** description is in use then the transmitter must be configured so that it can operate with the old **VALMET** description.

The change from description to another is made by writing to **MESSAGE**-field either. **VALMET** or **SATRON** (Note, capital letters and dot in front). After writing the message the new description will be activated by switching transmitter's power **OFF** and **ON** again.

2.1 Using the 275 user interface

Operation keys

The six operation keys are located above the alphanumeric keyboard:

The ON/OFF key (**I/O**) switches the user interface on and off. When you switch the user interface on, it starts looking for a HART® transmitter connected to it. If the transmitter is not found, the message “**No Device Found. Press OK**” will be displayed.

The **ONLINE** menu is displayed when the user interface finds the transmitter.

(**^**) This key allows you to move upwards in menus and scroll lists forwards.

(**v**) This key allows you to move downwards in menus and scroll lists backwards.

(**<**) This two-function key allows you to move the cursor to the left and to go back to a previous menu.

(**>**) This two-function key allows you to move the cursor to the right and to select a menu option.

(**>>>**) The quick-selection key will start the user interface and display the quick-selection menu. You can define the desired menu as quick-selection menu.

Function keys

With function keys F1, F2, F3 and F4 you can perform the program functions displayed above each function key. When you move in the software menus, the functions of these keys will change in accordance with the currently selected menu.

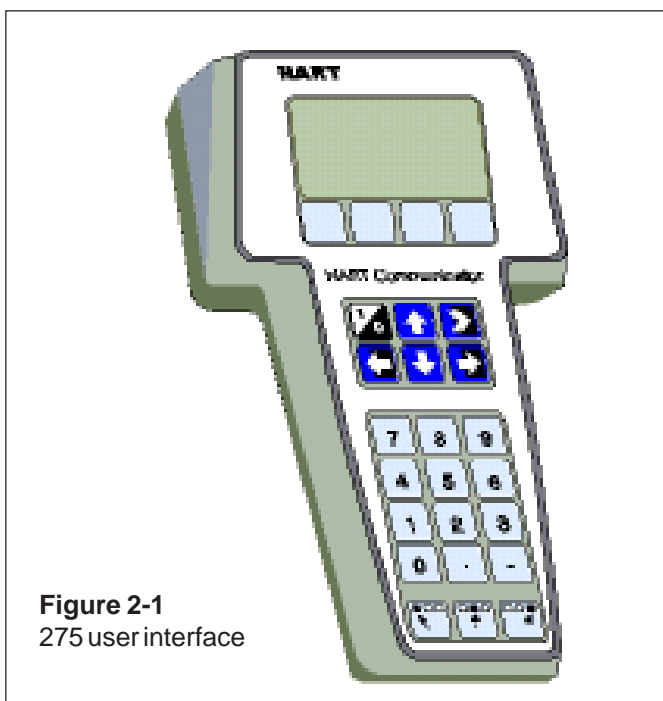

Figure 2-1
275 user interface

2.2 Setting up through HART® 275 user interface

After installing and connecting the transmitter, connect the user interface to the transmitter. The following menu is displayed:

- 1 Measurement
- 2 Configuration
- 3 Information
- 4 Diagnostics

To change the measuring range, unit damping time constant to output mode (linear/square-root), select **Configuration**.

The following menu is then displayed:

- 1 Range values
- 2 Detailed config

To change the measuring range, select **Range values**.

The selection displays the following menu:

- 1 LRV (lower range value)
- 2 URV (upper range value)
- 3 LSL (lower sensor limit)
- 4 USL (upper sensor limit)
- 5 Min span (minimum span)
- 6 Apply values

To change the measurement unit, damping time constant or output mode, select **Detailed config** from the **Configuration** menu.

The selection displays the following menu:

- 1 Damping
- 2 Pres. unit
- 3 Tempr. unit
- 4 Alarm current
- 5 Write protect
- 6 Lin. func
- 7 Diff EI status
- 8 Burst mode
- 9 Burst option
- Poll addr
- Tag
- User function
- User funct. setup

After these activities or if the transmitter is supplied with the ready configuration you must correct a zero error of the transmitter in a final installation position.

Press **Diagnostics** and **PV Zero calibr.**

The selection displays the following menu: **Give correct value for Zero pressure in ...**

The current zero point will be shown in display and the final zero error correction can be done.

2.3 Using the 375 user interface



Figure 2-2
375 user interface

2.4 Setting up through HART® 375 user interface

After installing and connecting the transmitter, connect the user interface to the transmitter. The following menu is displayed: **Main menu**. To select the **HART Application**.

The following menu is then displayed:

- 1 **Measurement**
- 2 **Configuration**
- 3 **Information**
- 4 **Diagnostics**
- 5 **Review**

To change the measurement unit, damping time constant or output mod, select **Configuration**.

The following menu is then displayed:

- 1 **Range values**
- 2 **Output**
- 3 **Transfer function**
- 4 **General setup**

To change the measurement unit, select **Range values**.

The following menu is then displayed:

- 1 **LRV**
- 2 **URV**
- 3 **LSL**
- 4 **USL**
- 5 **Min span**
- 6 **Apply values**

To change the damping time constant, select **Output** from the **Configuration** menu.

The following menu is then displayed:

- 1 **Damping**
- 2 **Alarm current**

To change the output mode, select **Transfer function** from the **Configuration** menu.

The following menu is then displayed:

- 1 **Lin. func**
- 2 **User function data**

After these activities or if the transmitter is supplied with the ready configuration you must correct a zero error of the transmitter in a final installation position.

The First press **Diagnostics** and then **Sensor trim** and then **Zero trim**

The following text is then displayed : *WARN-Loop be removed from automatic control*

The final zero error correction can be done to select **ABORT** or **OK** on the display .

2.5 Setting-up with Satron-pAdvisor Service Software

When you will have available all the operations of the Smart transmitter, we recommend the use of Satron-pAdvisor Service Software and Satron SI-Tool[®] USB-Hart-modem in setting-up.

Test connections for configuration and pressure/ output current values checking and calibration and for SENSOR TRIM function

Recommended equipment for calibration

Satron-pAdvisor service software for SATRON Smart transmitter (can be loaded free of charge from www.satron.com)

PC: operating system Win-98, Windows 2000 or Windows XP)

DMM: Digital multimeter, basic DCV accuracy better than 0,01 % of reading (for example Fluke 8840A, Keithley 2000)

Cal. pressure generation and measurement device (accuracy better than 0,03 % of reading)

USB-Hart modeemi, Satron SI Tool[®], tilauskoodi: **M1330001**

Digital multimeter for output current measuring

PC

Cal. pressure generation and measurement device

V series transmitter

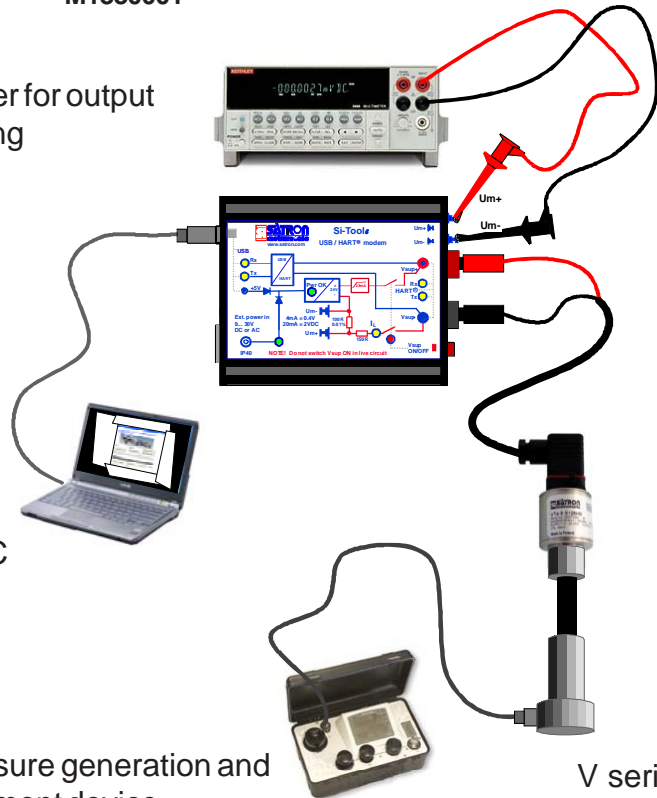

Figure 2-2 Calibration connections window

2.6 Setting-up with local switches

The additional instruction of display menus is enclosed to this manual.



Keyboard :

- Esc = Press **Esc** move back towards the top of the main menu.
- ▲ = Use the **UP** arrow key to move up on the current menu level or to increase the selected parameter value.
- ▼ = Use the **DOWN** arrow key to move down on the current menu level or to decrease the selected parameter value.
- Enter = Press **ENTER** to move to a lower level in a menu or to accept a command or parameter value.

Figure 2-3 VV pressure transmitter with display

275 software tree
(Valmet transmitters)

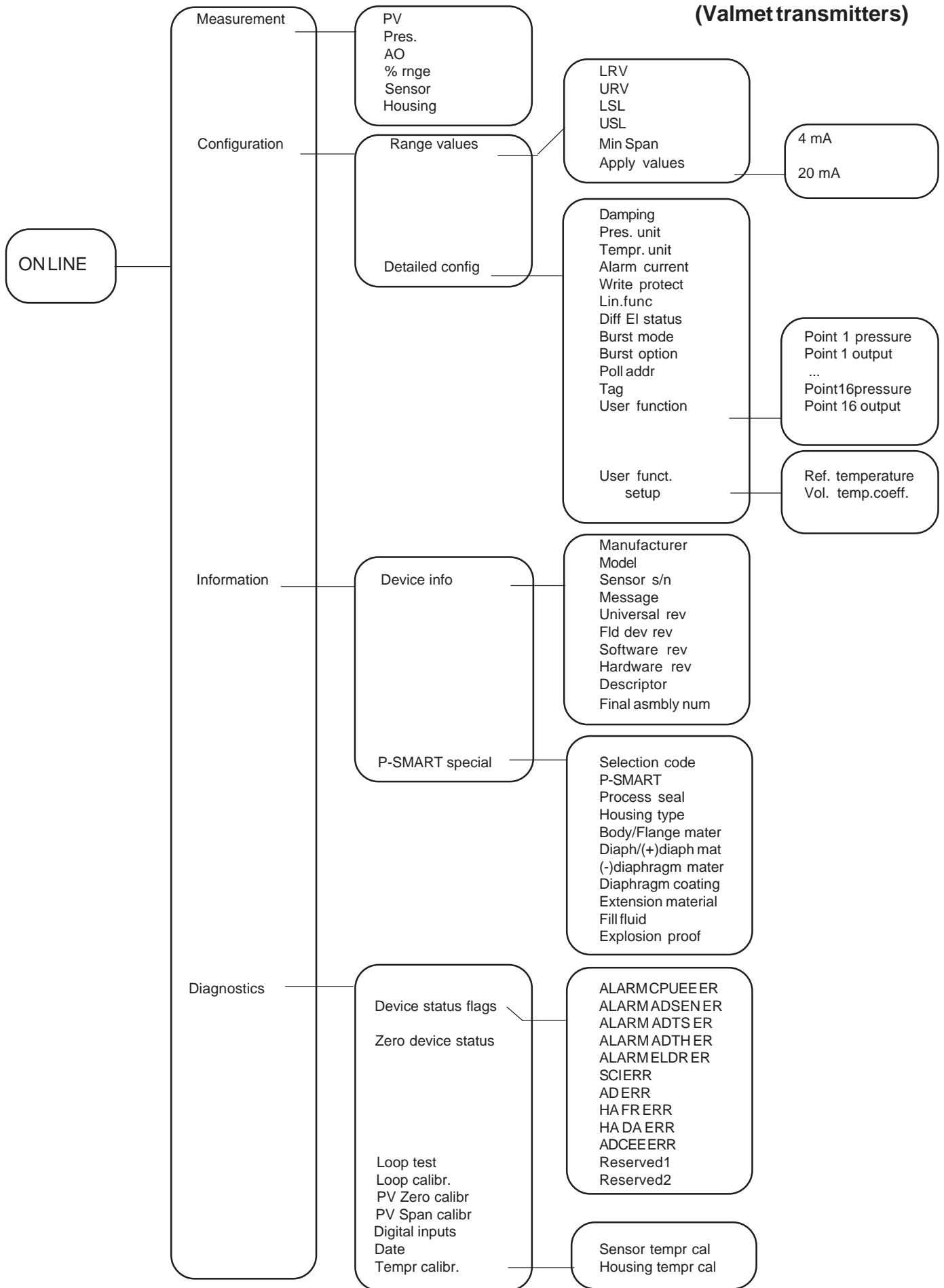

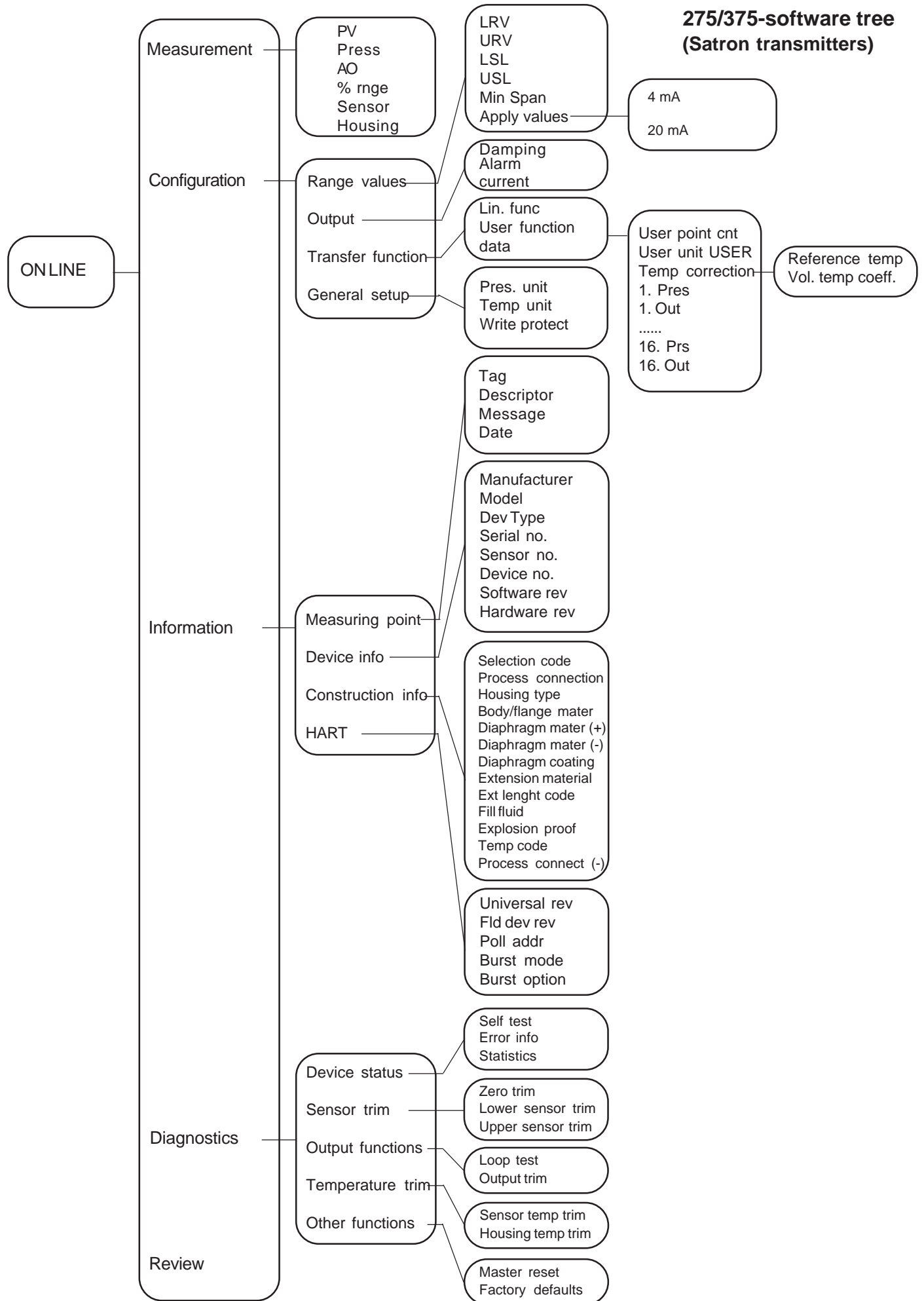

2.7 Set-up calibration, housing code T (with manual adjuster)

The transmitter is factory-calibrated, with 1 sec. electrical damping, for the range specified in the order. If range is not specified, the transmitter will be calibrated for the maximum range.

Zero and Span adjusters are at the end of the housing, under protective rubber shield. TEST jacks are also under protective rubber shield. Figure 2-4: housing T with PLUG connector

Checkout procedure

- See that the ripple on the supply voltage does not exceed $2.5 V_{pp}$ on 0-1000 Hz frequency range.
- Check the nameplate for the factory-calibrated range and zero suppression/elevation.
- If necessary, readjust the zero.

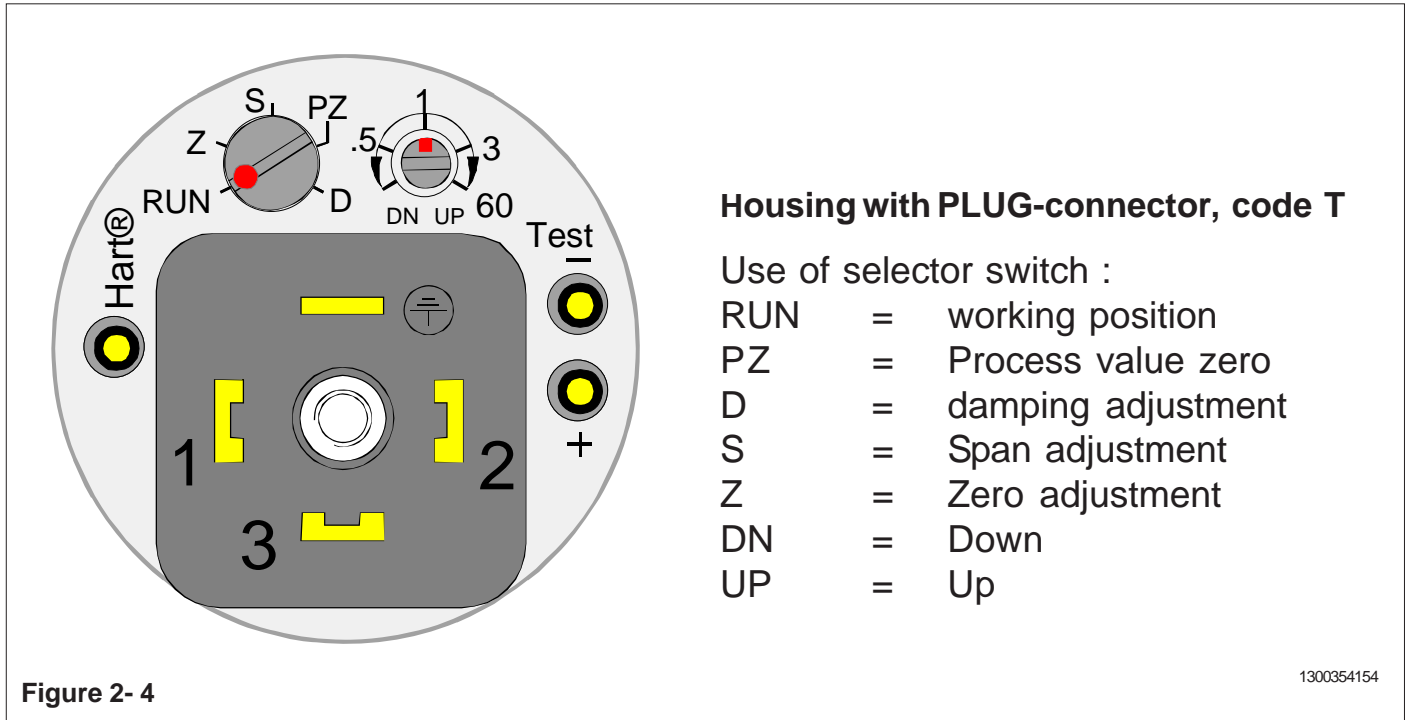

3 CALIBRATION

3.1 Adjustability

Maximum span is 25 times the minimum span for SATRON VV transmitter

Span adjustments is made from outside the housing, under the protective rubber shield (figure 3-1).

Zero suppression and elevation

Maximum zero suppression is 86 % of max.span, and maximum zero elevation is 100 % of max. span. Zero adjustments is made from outside the housing, under the protective rubber shield (figure 3-2).

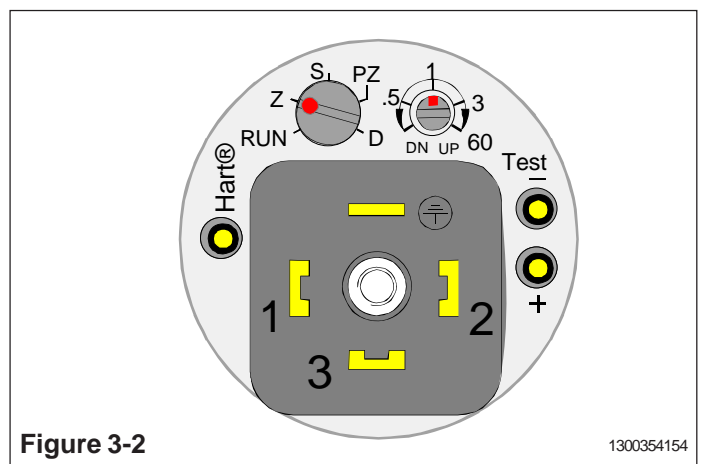
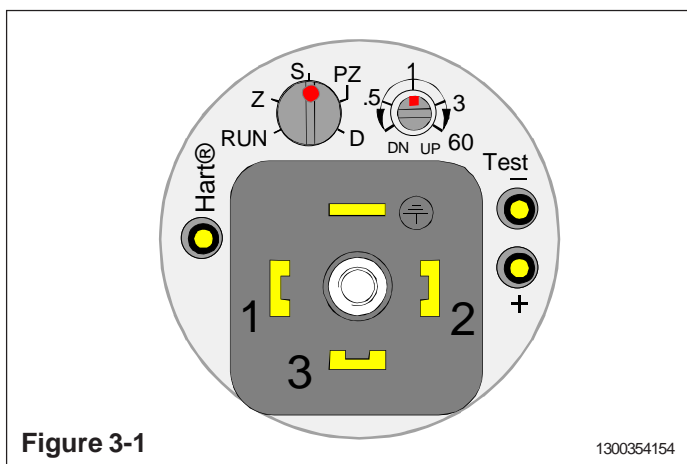

Measuring range

The lower and upper range-values cannot differ from zero by more than the maximum span.

For example, range transmitter whose measuring range is 0-4/100 kPa cannot be adjusted to measure 100...104 kPa pressure, because maximum span is 100 kPa.

3.2 Damping

If pulsation occurs in the measured pressure, it can be damped with the damping trimmer position D under the protective rubber shield on the housing.

The transmitter is factory-calibrated with minimum electrical damping.

To increase the damping, turn the trimmer clockwise.

Adjusting the damping does not affect the transmitter's other calibration.

Damping adjustment :

1. Turn the selector switch from RUN to position D
2. Turn the regulating switch about $\pm 20^\circ$ so damping adjustment is activated. Turn the regulating switch to desired value of damping. 0 s on the left side, 60 s on the right side.
3. Turn the selector switch from position D to position RUN.

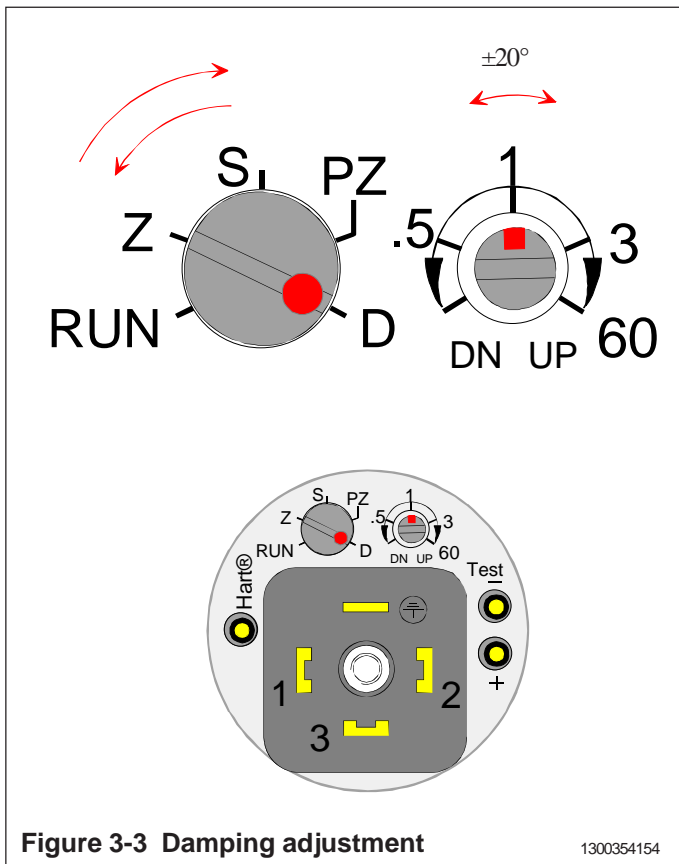

Figure 3-3 Damping adjustment

1300354154

3.3 Calibration examples

First step is process value zero :

1. Turn the selector switch from position RUN to position PZ.
2. PV ZERO is done when the damping trimmer is turned once to both edges at least for 1 sec.
3. Turn the selector switch from position PZ to position RUN.

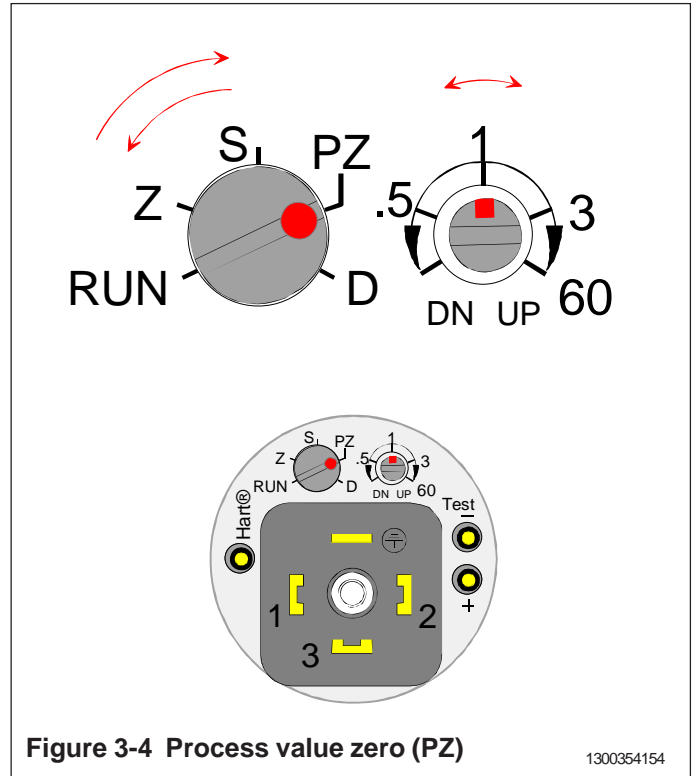

Figure 3-4 Process value zero (PZ)

1300354154

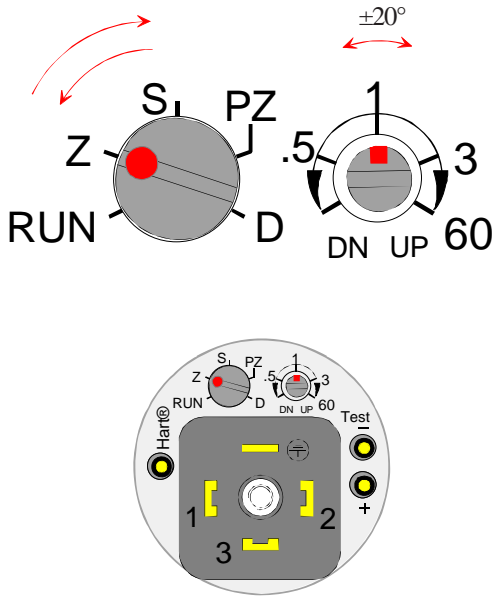

Figure 3-5 Set the lower range-value

1300354154

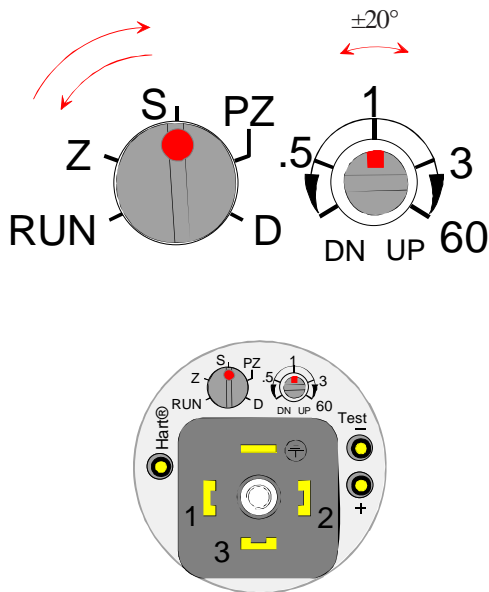

Figure 3-6 Set the upper range-value

1300354154

Measuring range: 0...200 kPa (range 5 transmitter).
Span: 200 kPa

Procedure

- Apply zero pressure.
- 1. Turn the selector switch from position RUN to position Z.
- 2. Turn the regulating switch about $\pm 20^\circ$ so adjustment is activated.
- 3. Turn the regulating switch to a point where output is closest to 4 mA. (adjustment range on fine adjustment range is $\pm 0.75\%$ of span and speed of adjustment is $\pm 2.5\%$ of span / s)
- 4. Turn the selector switch from position Z to position RUN.

- Apply full-span pressure.
- 1. Turn the selector switch from position RUN to position S.
- 2. Turn the regulating switch about $\pm 20^\circ$ so adjustment is activated.
- 3. Turn the regulating switch to a point where output is closest to 20 mA. (adjustment range on fine adjustment range is $\pm 0.75\%$ of span and speed of adjustment is $\pm 2.5\%$ of span / s)
- 4. Turn the selector switch from position S to position RUN.

- Apply zero pressure.
- Repeat the adjustments to achieve the desired accuracy.

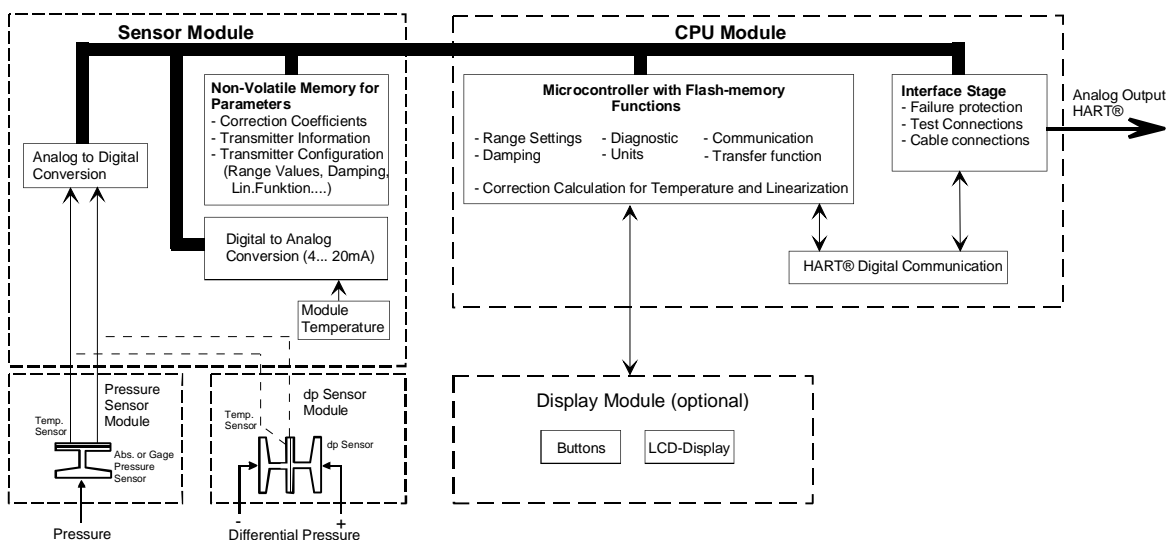

Figure 4-1 Functional construction of the SATRON VV pressure transmitter

1300354156

4. CONSTRUCTION AND OPERATION

4.1 Smart transmitter

Sensor Module

The piezoresistive sensor, which has a silicone oil fill, is isolated from the process with a diaphragm. Sensor pressure and temperature are measured with a 24-bit AD converter. Linearity and temperature effects are digitally corrected with an internal microprocessor connected to the sensor module.

The **sensor** converts pressure to electrical signal. The conversion is carried out through a Wheatstone bridge supplied with direct current. The elastic displacement produced in the bridge by the pressure causes bridge unbalance which is measured as a DC voltage signal.

Compensation includes temperature compensation and linearization. Each sensor is calibrated individually through a resistance network connection. The temperature information required by compensation is derived from a temperature measuring element located by the Wheatstone bridge.

Electronics Module

The electronics module converts the process pressure signal from the sensor module to 4-20 mA output signal. The conversion can be made in linear, square root or inverted mode, or it can be done through user-selectable pressure/output point pairs (2-16 points).

Transmitters provided with own display (code **N**) is equipped with operating keys that allow you to define the transmitter's all functions.

The active functions required for **signal shaping** are in a customized IC which is divided into two sub-blocks: amplifier block and standard-signal shaping block. The standard-signal shaping block also includes zero, span and damping adjustments.

The **interface stage** includes failure protections to ensure the transmitter's operation and nonfailure in possible failure conditions. This stage also includes the TEST and cable connections

5. PARTS LIST

When ordering spares, please quote this document's number BLV810AV and date 15.2.2013, the name and order number of the required part, and the transmitter's serial number. Parts indicated with asterisk (*) as well as screws, nuts and seals (packings) are spare parts.

Number	Name	Order number	Number	Name	Order number
1	Sensing element		* 15	Mounting clamp	T544953
2	Seal	T1300207	* 16	Support plate	T543223
* 3	Device plug DIN43650	72900114	17	Hex nut	56022800
4	Cylinder-head screw M3 x 10 SFS2179 Zne	51603021	* 18	Mounting bracket S	T1050009
8	Seal GDM3-17,silicone	72900116	19	O-ring, 42x2 FPM (Viton®)	80013800
* 9	Wiring box GDM3009, DIN43650	72900111	* 20	Cover M	T1300256
10	Cylinder-head screw S M3 x 35 SFS2179 A4	51723053	21	Seal, Silicone rubber	T1300387
11	Cylinder-head screw S M3 x 4 VSM 13302 Zne	51613009	* 22	Back plate V	T1300391
* 13	Protection cup, housing H, M and T	T1300295	23	Fastening screw M4	T1325347
* 13	Protection cup, housing N	T1300400	* 46	Flange (assembly)	
			* 47	Locking ring	T1002236
			* 48	Coupling nut	T1002233

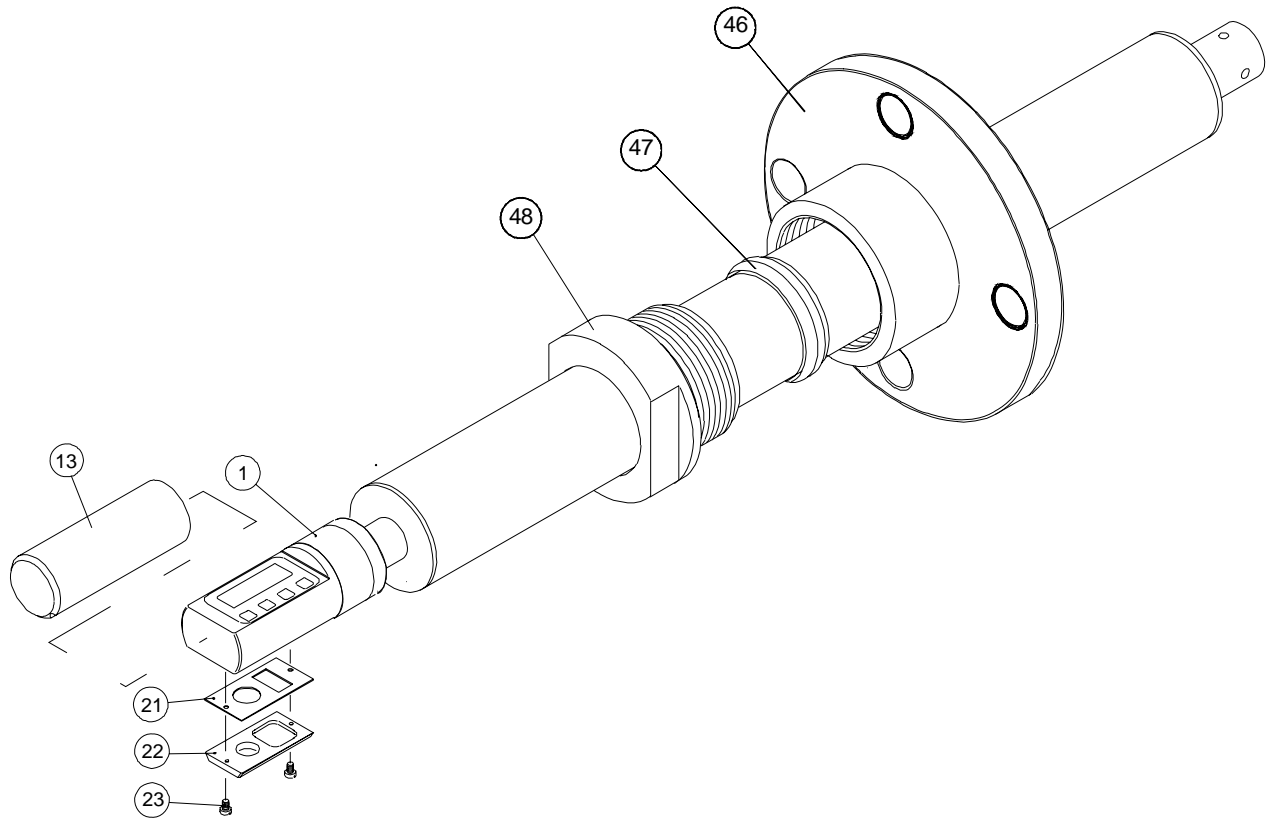

Figure 5-1 Parts list: Transmitter type VVP,
Enclosure N (with display)

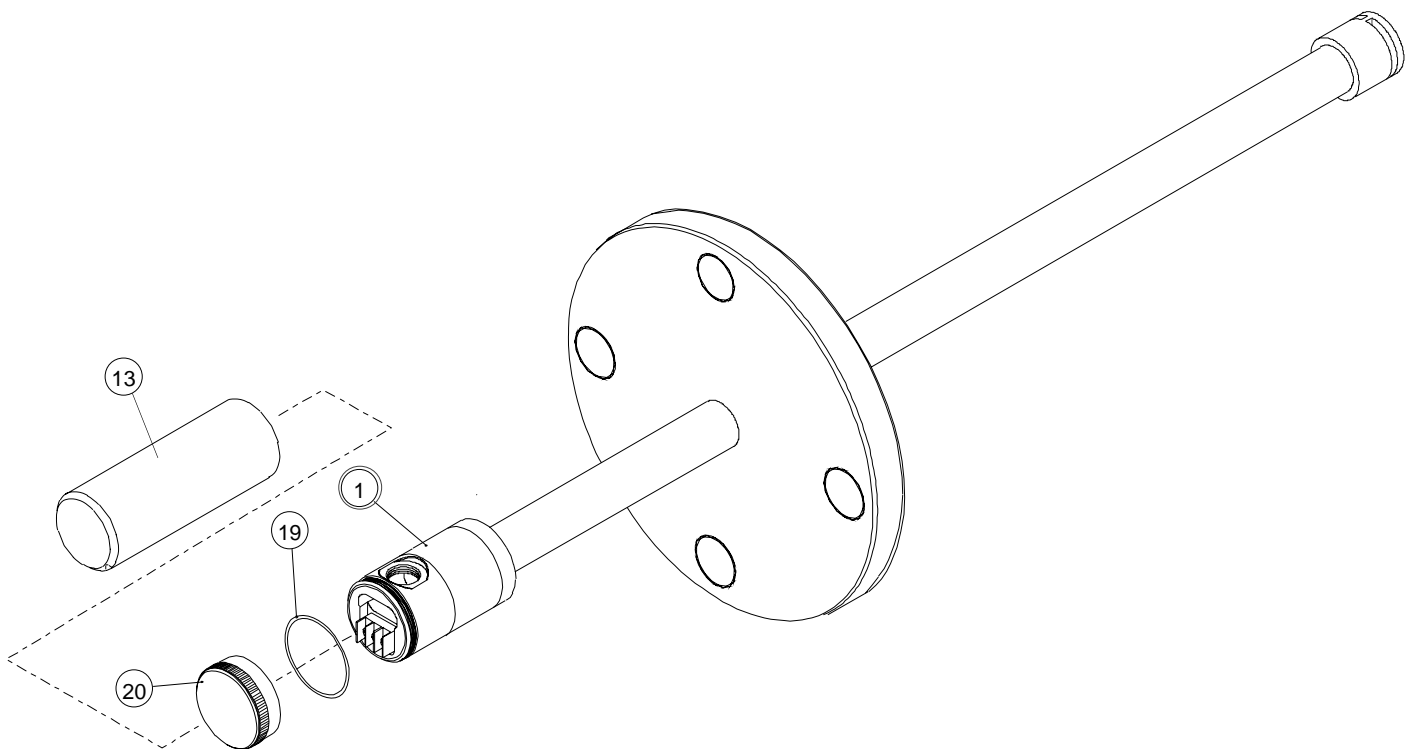

Figure 5-2 Parts list: Transmitter type VVH,
Enclosure M (Junction box)

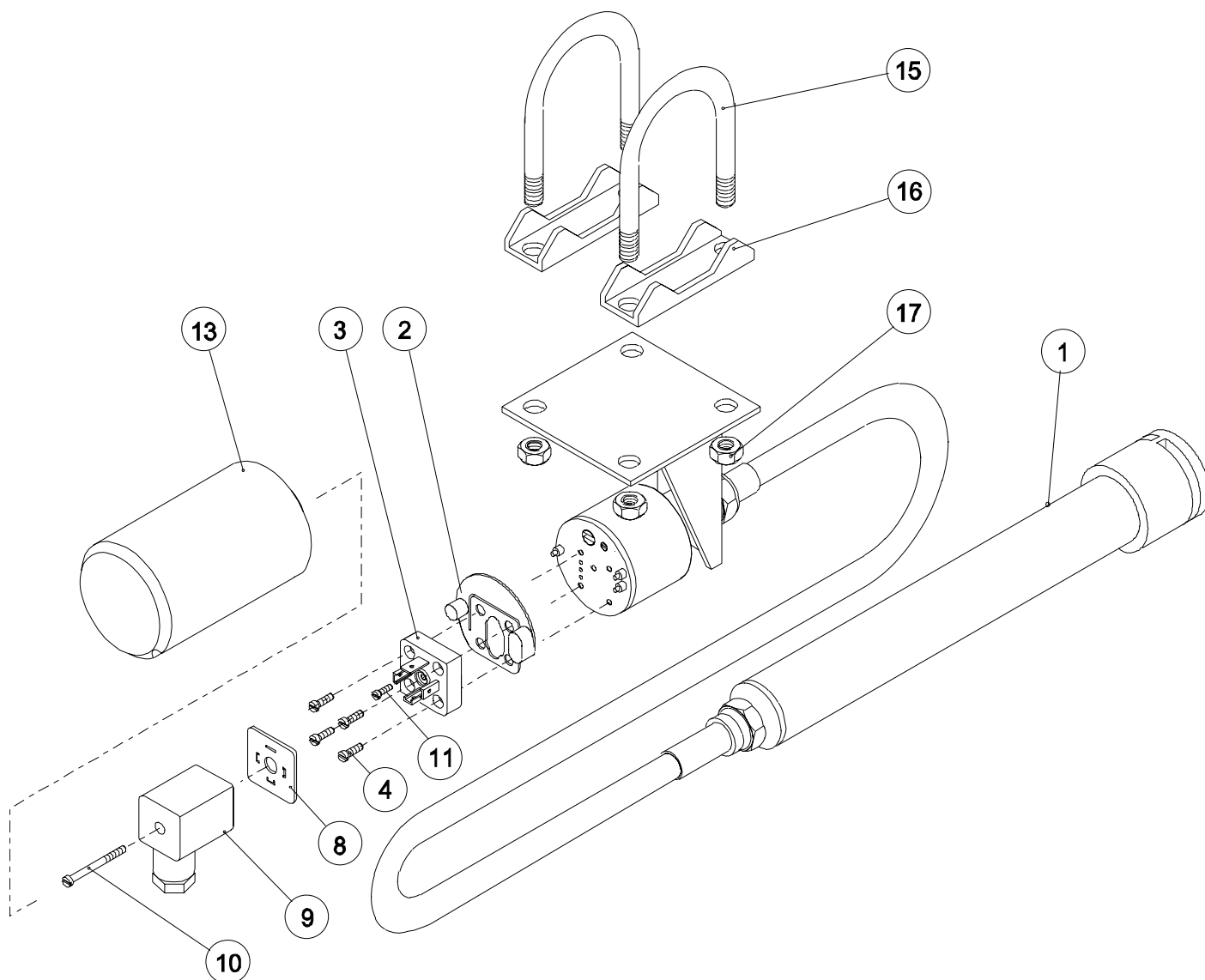

Figure 5-3 Parts list: Transmitter type VVF,
Enclosure H (PLUG connector)



Satron Instruments Inc.

P.O.Box 22, FIN-33901 Tampere, Finland

Tel.int. +358 207 464 800, Telefax +358 207 464 801

www.satron.com, info@satron.com

