

Mounting couplings for Satron VT Transmitters

G160
01.01.2015

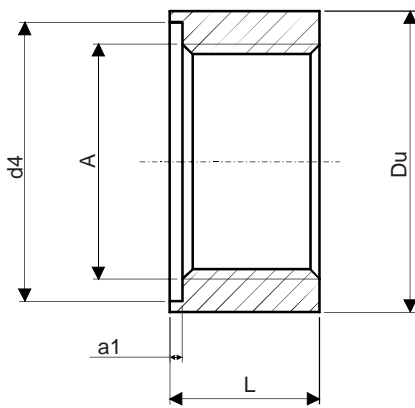

Process couplings with DIN 3852-X thread
Order code: AISI316L

Order code	Thread A	Du $^{0}_{-0.5}$	Length L	d4	a1
M1050369	G $\frac{1}{2}$	Ø30	18,5	Ø27	2.5
M1050390	G1	Ø45	23.5	Ø40	2.5
M1050391	G $\frac{1}{2}$	Ø60	32.5	Ø56	2.5
M1050393	G $\frac{1}{2}$	Ø60	26.5	Ø56	2.5
M1050392	G2	Ø75	33	Ø69	3.0

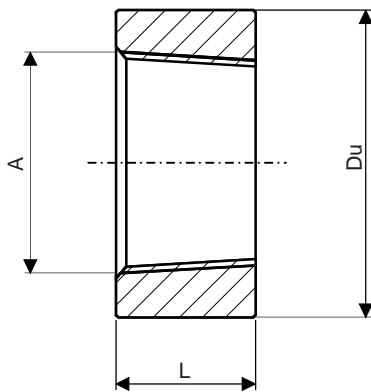

Process couplings with NPT thread

Order code: AISI316L

Order code	Thread A	Du	Length L
M1050368	$\frac{1}{2}$ -14 NPT	Ø28	14
M1050500	$\frac{3}{4}$ -14 NPT	Ø35	16
M1050501	1 - 1 $\frac{1}{2}$ NPT	Ø44.5	20.5
M1050502	1 $\frac{1}{4}$ - 1 $\frac{1}{2}$ NPT	Ø57.5	20.5
M1050503	1 $\frac{1}{2}$ - 1 $\frac{1}{2}$ NPT	Ø63.5	20.5
M1050504	2 - 1 $\frac{1}{2}$ NPT	Ø76	20.5

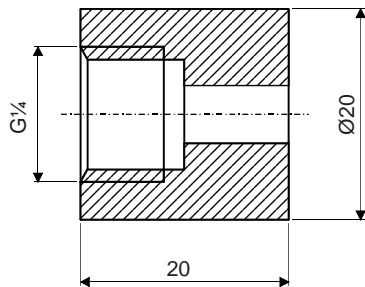

Process coupling DIN 16288 - G $\frac{1}{4}$

Order code:

- AISI316L

M1050366

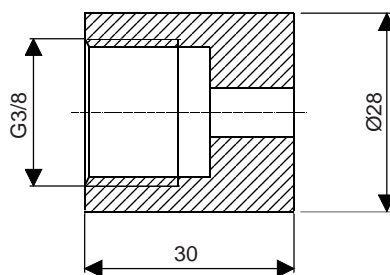

Process coupling G $\frac{1}{2}$

Order code:

- AISI316L

M1050316

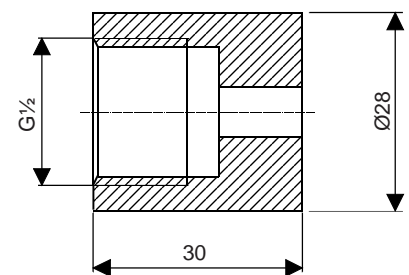

Process coupling DIN 16288 - G $\frac{1}{2}$

Order code:

- AISI316L

M1050367

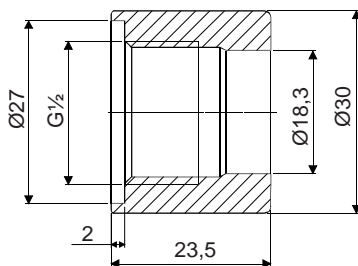

Process coupling DIN 3852 - X - G $\frac{1}{2}$, for transmitter with two o-ring

Order code:

- AISI316L

M1050515

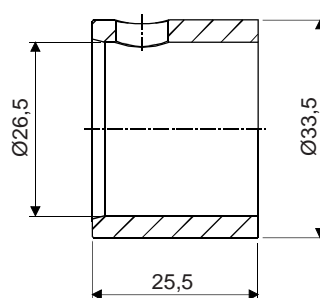

Process coupling PMC 1"

Order code:

- AISI316L

M1050300

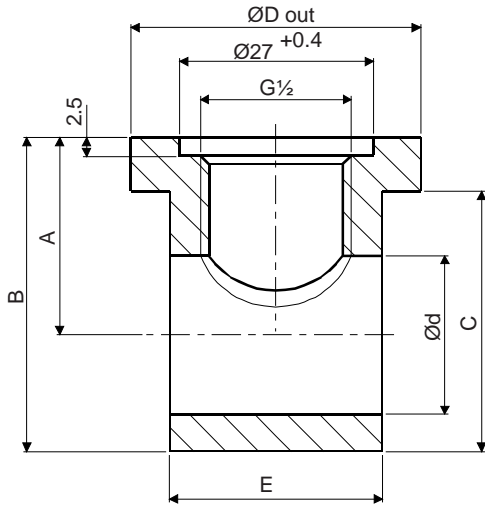

T-coupling DIN 3852-X-G½

Order codes: AISI316L

Pipe size	Dim. ØD out	Dim. A	Dim. B	Dim. C	Dim. Ø d	Dim. E	Order code
DN15	40	27.5	43.5	36	22 $\begin{smallmatrix} +0.2 \\ 0 \end{smallmatrix}$	29.5	M1050395
DN20	40	30.5	49	42	27.5 $\begin{smallmatrix} +0.3 \\ 0 \end{smallmatrix}$	26	M1050396
DN25	50	33.5	55.5	48	34 $\begin{smallmatrix} +0.5 \\ +0.2 \end{smallmatrix}$	29.5	M1050397

Other size, please contact Satron Instruments Inc.

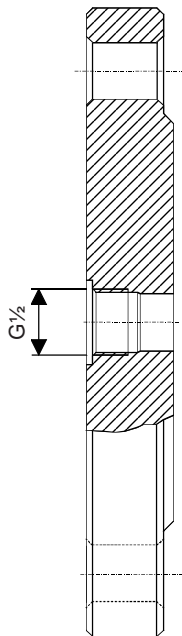

Coupling flange DIN 3852-X-G½ - for the transmitter with two o-rings Tilaukoodit: AISI316L

ORDER CODE	TYPE OF FLANGE
M1050517-DN25	DN 25 PN 40
M1050517-DN40	DN 40 PN 40
M1050517-DN50	DN 50 PN 40
M1050517-DN80	DN 80 PN 40
M1050517-DN100	DN 100 PN 16
M1050517-1-150	ANSI 1" 150 LBS
M1050517-1-300	ANSI 1" 300 LBS
M1050517-2-150	ANSI 2" 150 LBS
M1050517-2-300	ANSI 2" 300 LBS
M1050517-3-150	ANSI 3" 150 LBS
M1050517-3-300	ANSI 3" 300 LBS
M1050517-4-150	ANSI 4" 150 LBS
M1050517-4-300	ANSI 4" 300 LBS

Special flanges, please contact Satron Instruments Inc.

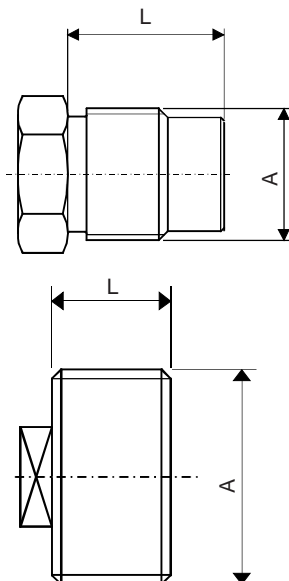

Welding assistant: Order codes

Order code	Thread A	Dim. L	Position, form and size
M1050516	G½A	25	6-k, AV22
M1050375	G¾A	15	6-k, AV27
M1050371	G1A	20	6-k, AV36
M1050372	G1 ¼A	35	4-k, AV22
M1050373	G1 ½A	35	4-k, AV22
M1050374	G2A	35	4-k, AV22