

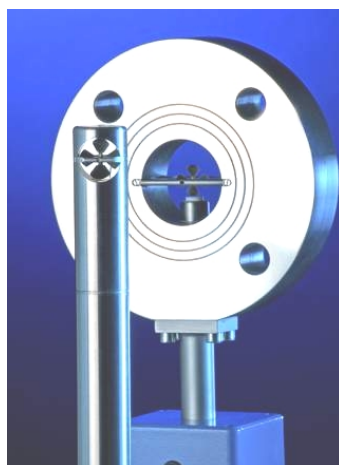

Transducers UFA / UVA in AS102 housing

Operating Instructions



Vane wheel flow sensors FA

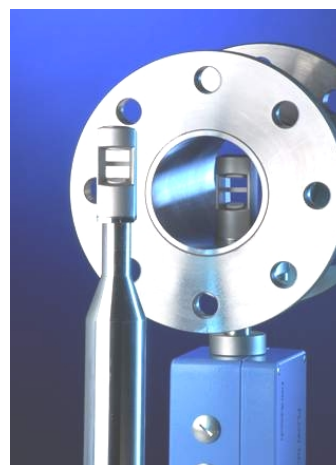

Vortex flow sensors VA

Höntzsch GmbH

P.O. Box 1324 D-71303 Waiblingen
Gottlieb-Daimler-Straße 37
D-71334 Waiblingen (Hegnach)
Tel: 07151/1716-0
Fax: 07151/58402
E-Mail info@hoentzsch.com
Internet www.hoentzsch.com

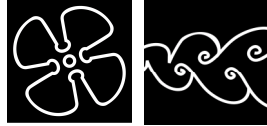

Contents

1	Safety Symbols
2	Application according to Regulations
3	Operating Safety
4	Scope of Delivery
4.1	Description, Type Plates
5	Technical Specifications
5.1	Conformity with Standards
5.2	Storage Conditions
5.3	Operating Conditions
5.4	Compatibility
5.5	Housing and Connectors
5.6	Electrical Data
5.7	Measurement Uncertainty
6	Installation
6.1	Block Diagram
6.2	Wiring Diagrams
6.2.1	Shielding contact at cable bush
6.2.2	Power supply
6.2.3	Sensor input
6.2.4	Analog output
6.2.5	Relay
6.2.6	RS232 interface
6.2.7	optional LCD
6.3	Tips on Electromagnetic Compatibility (EMC)
6.4	Connecting Cable
7	Functional Description
8	Settings
9	Performance Test
10	Initial Operation
11	Operation
12	Shut-down, Dismantling
13	Inspection
14	Maintenance
15	Calibration
16	Troubleshooting
17	Returns
18	Disposal
19	Replacement Parts
20	CE Declaration of Conformity, Manufacturer's Declaration



1 Safety Symbols



Warning!

Failure to observe the instructions can result in serious injury and damage to property!



Important notice!

Non-observance can result in serious damage to the equipment or restriction in performance!

2 Application according to Regulations



Transducers UFA and UVA are instruments for measuring flow velocity and flow rate: UFA for use with vane wheel flow sensors FA or FAR and measuring tubes FA Di or FAR Di and UVA for use with vortex flow sensors VA40 and measuring tubes VA Di. These instruments are designed for industrial application. The AS102 is an aluminium housing in protection class IP65.

The manufacturer is not liable for damage caused by improper use and/or non-compliance with the regulations.

Do not carry out any structural modifications to the transducers.

Always follow the instructions on the type plate, especially the information regarding supply voltage.

3 Operating Safety



All steps described below must be carried out by qualified personnel only!

Please read the Operating Instructions carefully before unpacking the equipment!

Safety can only be guaranteed if the equipment is operated in accordance with the regulations. Improper handling can result in serious injury and damage to property.

4 Scope of Delivery

- Transducer UFA or UVA in AS102 aluminium housing
- LCD display 2x16 digit in the cover (optional)
- Operating Instructions, Data Sheet
- CD-ROM with PC configuration software UCOM (optional)
- Interface cable RS232 for PC COM port connection (optional)
- USB adapter in addition to the interface cable RS232 (optional)

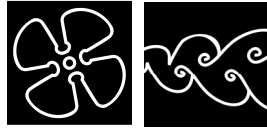

Please check that everything listed in the Delivery Note / Technical Data Sheet is included in the delivery.

4.1 Description, Type Plates

One of the following type plates can be found on removing the cover:

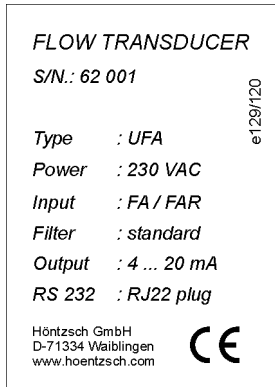

Type plate UFA

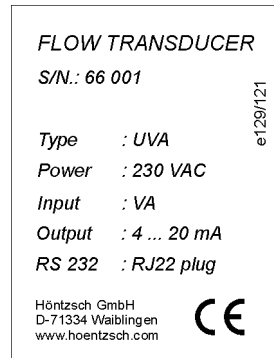

Type plate UVA

Type:	UFA	: transducer for vane wheel flow sensors
	UVA	: transducer for vortex sensors
S/N.:		: serial number
Power:	230 VAC	: supply voltage 230 V AC voltage
	24 VDC	: supply voltage 24 V DC voltage
	12 VDC	: supply voltage 12 V DC voltage
Input:	FA/FAR	: input for vane wheel sensors FA or FAR
	VA	: input for vortex sensors
Filter:	...	: filtration of vane wheel input frequency
Output:	4-20 mA	: analog output current 4-20 mA
	0-10 V	: analog output voltage 0-10V
RS232:	...	: RJ22 plug

5 Technical Specifications

5.1 Conformity with Standards

Transducers UFA / UVA are manufactured according to the best available technology, are safe and reliable and comply with the relevant regulations, EU directives and standards.

IEC 529 and EN 60 529	:	protection class IP65
EN 61 000-6-2 / IEC77	:	EMC



5.2 Storage Conditions

Storage temperature: -30 to +70 °C



5.3 Operating Conditions

ambient air temperature in use: -25 to +50 °C
with optional LCD: 0 to +50 °C

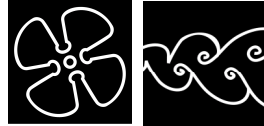

protection class: IP65

mounting attitude: no restrictions, preferred with cable bush downward.

5.4 Compatibility

All Höntzsch vane wheel probes FA or FAR and all Höntzsch vane wheel measuring tubes FA Di or FAR Di (without integrated transducer) can be connected to the UFA transducer. The UFA replaces the U2a transducer with FA / FAR input.

All Höntzsch vortex probes VA and all Höntzsch vortex measuring tubes VA Di (without integrated transducer) can be connected to the UVA transducer. The UVA replaces the U2a transducer with VA input.

5.5 Housing and Connectors

protection class	: housing IP65
material	: aluminium
external dimensions	: L/W/H = 150/100/80 mm
cable bush	: screwed cable glands in nickel-plated brass for cable diameter 5 ... 10 mm with shielding contacting
connections	: 'push-in' circuit board terminals for wires with cross-section 0.14 ... 1.5 mm ² . No tools necessary for strand connection, simply insert the strand ends (twisted or with end sleeve) into the terminal. Separate strands by applying pressure to the terminal release spring with a pen or screwdriver.

5.6 Electrical Data

Supply voltage, mains supply:

230V AC	(215 ... 255 V AC), 50 ... 60 Hz,	power < 10 VA
24 V DC	(20 ... 27 V DC),	power < 5 W
12 V DC	(10 ... 17 V DC),	power < 5 W

The mains supply is electrically isolated from the UFA/UVA inputs and outputs.

UFA input flow v/FA or v/FAR:

for Höntzsch vane wheel flow sensors FA and FAR designed as probes (ZS, TS ..., ZSR, TSR ...) and as measuring tubes (FA Di, FAR Di ...).

When using sensors in Ex-zone category 2 an isolation/supply unit (e.g. LDX2) is an essential requirement.

UVA input flow v/VA:

for Höntzsch vortex flow sensors VA designed as probes (VA40 ...) and as measuring tubes (VA Di ...). When using sensors in Ex-zone categories 1 and 2 an isolation/supply unit (e.g. LDX2) is an essential requirement.

UFA analog output:

for FA and FAR*:	4 ... 20 mA	=	0 ... x m/s	(or m ³ /h),
for FAR	: 4 ... 12 ... 20 mA	=	-x ... 0 ... +x m/s	(or m ³ /h),
terminal values x configurable / burden max. 400 Ohm				

alternative:

for FA and FAR*:	0 ... 10 V	=	0 ... x m/s	(or m ³ /h),
for FAR	: 0 ... 5 ... 10 V	=	-x ... 0 ... +x m/s	(or m ³ /h),

terminal values x configurable / impedance 1 kOhm

* for FAR sensors when configuring the relay: ±flow directions

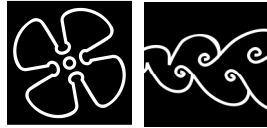

UVA analog output:

4 ... 20 mA = 0 ... x m/s (or m³/h),
terminal value x configurable / burden max. 400 Ohm,
alternative:
0 ... 10 V = 0 ... x m/s (or m³/h),
terminal value x configurable / impedance 1 kOhm

Relay: (potential-free change-over contact), max. 300 mA / 27 V DC
configurable as limit value v, quantity pulse or ±flow direction
(see under 7 - Functional Description)

RS232 interface:

for connection with UCOM (see under 7 Functional Description)
9600 Baud, 8Bit, no parity, 2 stop bits, Xon/Xoff

connection for optional LCD display:

flat ribbon cable with 10-pin connector
Do not plug in or out when live!

5.7 Measurement Uncertainty

Recording the measurement frequency (at 1000 Hz): <0.1%
Analog output (terminal value): <0.15%
Linearity error: <0.1%
Temperature coefficient: <20 ppm/K
(at 25 °K temperature difference equivalent to <0.05%)

6 Installation



Authoritative here are the European installation regulations EN 60079-10: 1996 ff, as well as the general engineering regulations and these Operating Instructions.

6.1 Block Diagram

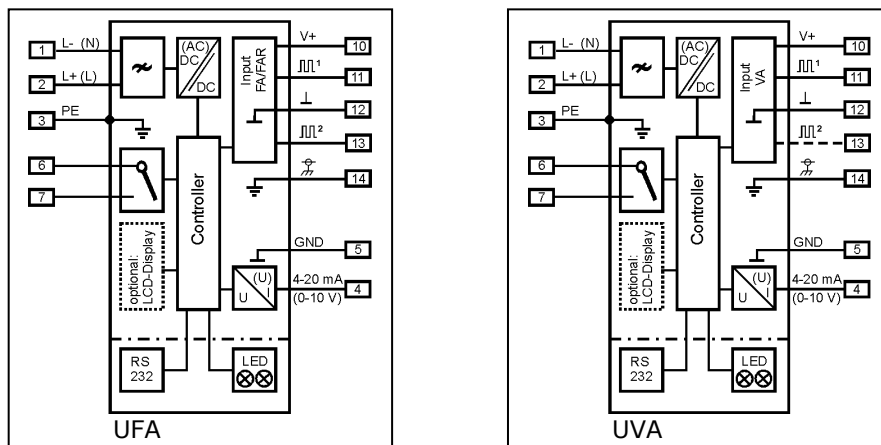

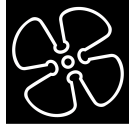

6.2 Wiring Diagrams



Electrical connection must be carried out according to the appropriate wiring diagram. **Faulty connection can cause damage to persons and destruction of the electronics.**

Do not install or wire up the transducer under mains voltage. **Non-compliance can cause damage to persons and destruction of the electronics.**

In this connection and depending on the configuration of the equipment, one of the following wiring diagrams must be taken into account. Wiring diagrams for measuring systems in customer-specific design will be supplied separately.

6.2.1 Shielding contact at cable bush

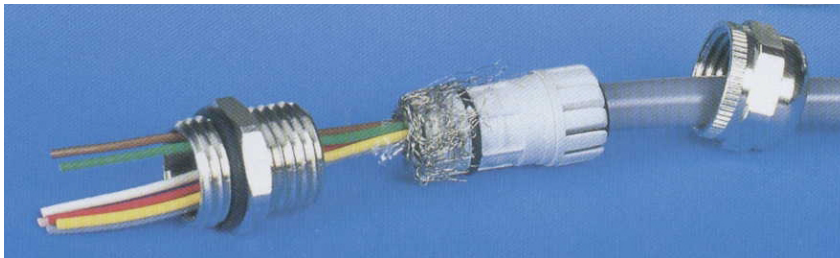

6.2.2 Power supply



Before connecting please check that the power supply is within the specification. Remove the housing cover of the UFA or UVA to reveal the type plate with all relevant information.



With a supply voltage of 230 V AC please ensure that the non-insulated areas of terminals and connecting cables are not touched when live!

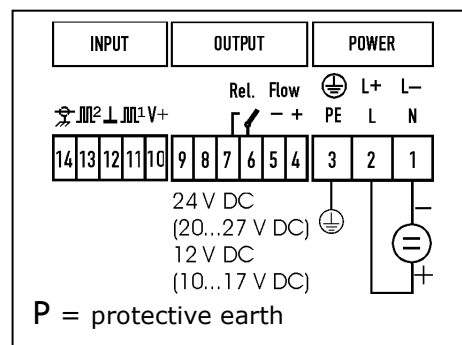
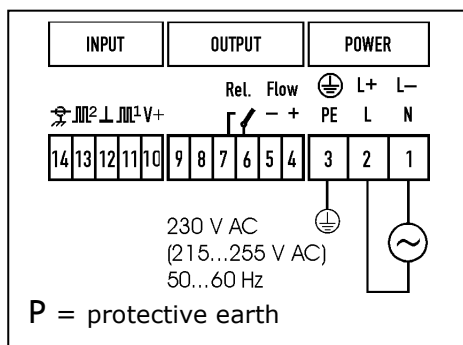

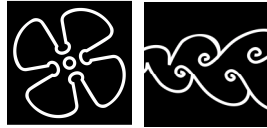

6.2.3 Sensor input

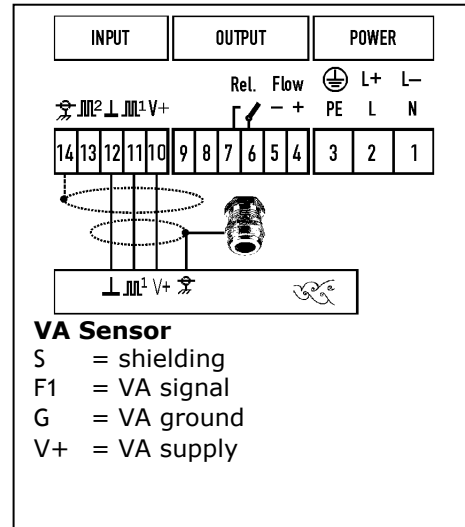
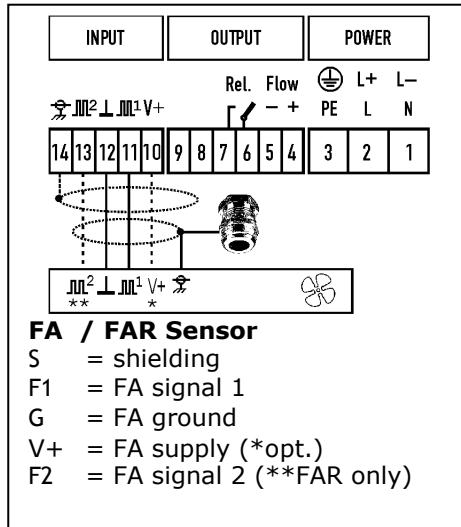

If the housing has a cable bush, shielding of the sensor connecting cable is contacted at cable bush.

6.2.4 Analog output

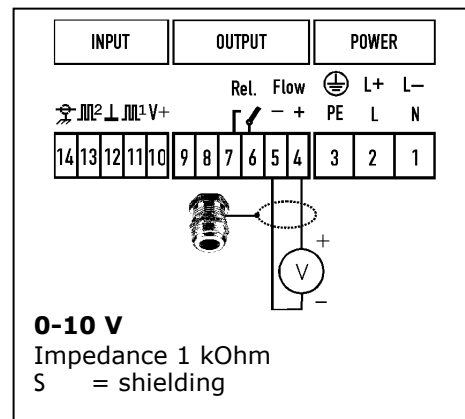
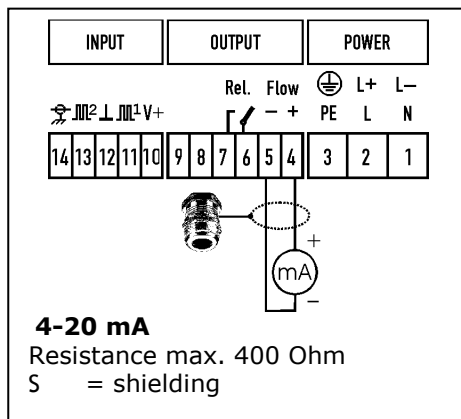

All relevant information can be found on the type plate.

The terminal value of the analog output can be configured with the PC software UCOM via the RS232 interface. The customer-specific programmed value can be found in the accompanying documents.

6.2.5 Relay output

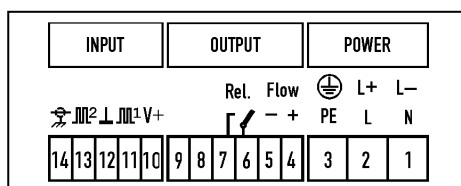

The change-over contact of the relay is shown in rest position (relay coil off).

The function of the relay output and the corresponding setting parameter can be configured with the PC software UCOM via the RS232 interface. The customer-specific settings can be found in the documentation.

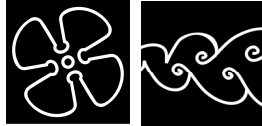

6.2.6 RS232 Interface



Fig. 1: PC connection with RJ22 plug with open cover

The RS232 interface connection is below left next to the connecting terminals. The RJ22 plug of the PC connecting cable is plugged in to the socket (see Fig. 1). PC connection follows at a COM port or using an optional USB adapter.

6.2.7 Optional LCD display in housing cover



Fig. 2: LCD display connection with cover open

The flat ribbon cable with 10-pin connector should not be plugged in or out when live! Risk to persons and equipment!

Visible are the readout potentiometer for the LCD display contrast, the reset button for the quantity counter, the ST1 and ST2 jumpers (see under 7 – Functional Description).

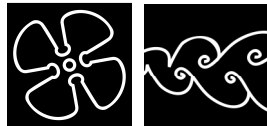

6.3 Tips on Electromagnetic Compatibility (EMC)

- all connecting cables are to be kept **as short as possible**
- with **cable routes longer than 30 m** or with strong electromagnetic disturbance along the cable route between sensor and evaluation unit, the use of a **double-shielded cable** is recommended: to do this lay inner shielding to one side of the evaluation unit and lay outer shielding on both sides over a large area with low-impedance connection on the sensor and evaluation unit or on the control cabinet
- **do not loop or kink** the cable!
- lay **non-allocated cable strands** on both sides **on protective potential!**
- **lay cables as close to ground as possible**, as for example side panels, mounting plates or steel girders
- when using **frequency converters** there is a **risk of HF interference**. Therefore, decouple the power input of the frequency converter against active emitted interference using a radio interference filter. This also increases the passive interference resistance of the facility
- between **engines** and **converters** use only shielded engine cables with double-sided shielding overlay
- **spatially separate cables which emit interference** from measuring lines and evaluation units. If necessary, lay measuring lines in a metallic tubular cable protection
- **metallic parts in control cabinets** such as sub racks with control electronics or sub plates – to be connected over a large area and HF-wise suitably conductive
- wire **relays, switches and magnetic valves installed in the same circuit**, using **spark extinguisher combinations** or over-voltage limiting components.
- apply **analog signal cable** shielding on one side only – preferably on the evaluation unit - and low resistant. Twist unshielded cables against balanced induction
- apply **digital signal cable** shielding on both sides over a large area. In the case of potential differences between these points it is advisable to lay a separate **equipotential bonding conductor**
- allow for preferred shielded connector for **connections to points of separation of connection cables**. **Terminals** should be situated in HF-tight housing, with suitable EMC cable bush. Contact outer shielding of the connection cables to the cable bush.

6.4 Connection Cable

For connecting between sensor and evaluation unit LiYCY cable with simple copper braiding screen can be used if the cable route is short and there is marginal electromagnetic interference. Over longer distances or with a high rate of electromagnetic interference, a double-screened cable of type LiYCY-CY should be used.

Sensor FA	2 (3) x 0.25 mm ²
Sensor FAR	3 (4) x 0.25 mm ²
Max. permissible conductor resistance per strand is 25 Ohm.	
Max. permissible operating capacity between 2 strands is 1.5 nF.	

Sensor VA	3 x 0.25 mm ²
Max. permissible conductor resistance per strand is 15 Ohm.	

Conductor resistances for finely stranded conductors:

approx. 79 Ohm/km	with wire cross section 0.25 mm ²
approx. 39 Ohm/km	with wire cross section 0.50 mm ²
approx. 26 Ohm/km	with wire cross section 0.75 mm ²

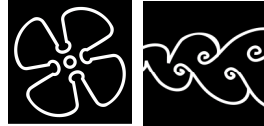

7 Functional Description

UFA transducers are designed for connecting to vane wheel probes FA and FAR (directional sensing) and vane wheel measuring tubes FA Di and FAR Di (directional sensing) for measuring flow velocity or flow rate of air/gases and water/liquids.

UVA transducers are designed for connecting to vortex probes VA and vortex measuring tubes VA Di for measuring the flow velocity or flow rate of air/gases.

The signal frequency proportional to the velocity generated from the flow sensor is converted to a linear **analog output signal** 4-20 mA or 0-10 V. The analog terminal value is configurable. When logging directional sensing data the zero point can be selected in the middle of the analog range or directional sensing takes place with the help of the relay output:

for FA and FAR*:	4 ... 20 mA	=	0 ... x m/s (or m ³ /h)
for FAR:	4 ... 12 ... 20 mA	=	-x ... 0...+x m/s (or m ³ /h)
for VA:	4 ... 20 mA	=	0 ... x m/s (or m ³ /h)

alternatively:

for FA and FAR*:	0 ... 10 V	=	0 ... x m/s (or m ³ /h)
for FAR:	0 ... 5 ... 10 V	=	-x ... 0...+x m/s (or m ³ /h)
for VA:	0 ... 10 V	=	0 ... x m/s (or m ³ /h)

* for FAR sensors for configuring the relay see under: \pm direction of flow

The actual velocity or actual flow rate can be converted to standard velocity or standard flow rate by entering the parameter for temperature and pressure.

A **relay output** (normally open contact) can be configured for **1 of 3** different **functions**:

- as **limit value** for the flow velocity or the flow rate:
 flow velocity < or = limit value: relay contact idle
 flow velocity > limit value: relay contact in working position
- as **quantity pulse** for quantity measurement:
 max. pulse repetition frequency 1 Hz per unit of volume,
 configurable, e.g. 1 pulse per 1, 10 or 100 (norm)-m³ or (norm)-litre
 pulse duration 0.5 s (FAR sensors: configurable for '+' or '-' amounts)
- as \pm direction of flow ** (for FAR sensors only):
 +direction: relay contact in idle
 - direction: relay contact in in working position
 ** analog output (see above) is then absolute value of flow only, without direction

Self diagnosis according to NAMUR NE43:

No error: yellow LED off
 green LED on (flow velocity = 0) or
 green LED flashes (flow velocity > 0)

Error: yellow LED on and with
 - analog output 4-20 mA : < 3.6 mA
 - analog output 0-10 V : < -0.2 V

Monitored: power supply, data logging, sensor interface, parameter settings (see under 16 - Troubleshooting)

PC serial port RS232:

for changing calibration data and setting parameters.

Remove cover.

Plug PC connector cable (optional) with RJ22 into the socket in the transducer (see Fig. 1).

Connect other end of cable to PC COM port.

If a USB connection is required, then an optional USB / RS232 interface converter must be inserted.

Changes to the settings can now take place after starting the PC programme UCOM (optional) (see under 8 - Settings).

optional LCD display in housing cover:

2 x 16 digit, character height 5.5 mm.

Display line 1: instantaneous value velocity or flow rate.

Display line 2: 'quantity counter' or 'error code'.

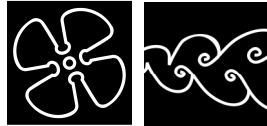

Configuration (see Fig. 1) via 2 jumper wrap connectors ST1 and ST2

Display line 1:

ST1 = m/s and ST2 = any: velocity in (N)m/s *
ST1 = m³/h (lt/h) and ST2 = A: flow rate in (N)m³/h
ST1 = m³/h (lt/h) and ST2 = B: flow rate in (N)lt/h **
* standard values (N) only when parameter 'switching v/NV' =1 (see under 8 - Settings)
** only when diameter Di < 75.0 mm, otherwise display in (N)m³/h

Display line 2:

Quantity counter in m³ with 0 ... 3 decimal places

In the case of FAR vane wheel sensors the display switches every 4 seconds between +quantity and -quantity.

(see under 8: parameter 'switching pulse m³(cbm) / l (litre)' and
parameter 'm³ (cbm) / l (litre) per pulse' and
parameter 'decimal places quantity display')

with error: error 01 = parameter error
error 02 = sensor error

(see under 16: Troubleshooting)

Reset button: (see Fig. 1)

Reset the quantity counter by pressing the reset button for more than 3 seconds

8 Settings

The following setting parameters can be read using the PC software UCOM and are also alterable. The customer-specific settings are shown on the parameter print-out, which is included in the documents.

Please find operation instructions PC software UCOM in document U385.



9 Performance Test

sensor not connected

(pay attention to 6.2.2 Power supply and 6.2.4 analog output)

after connecting the supply voltage the green and yellow LED light up.

The analog output sends a value between 3.4 mA and 3.6 mA with output current or between -0.3 V and -0.2 V with output voltage.



10 Initial Operation

sensor connected

(pay attention to 6.2.2 Power supply, 6.2.3 Sensor input and 6.2.4 analog output)

After connecting the supply voltage the green LED lights up and the yellow LED is off.

No flow at sensor: the green LED is permanently on, the analog output sends a value of 4 mA with output current (or 12 mA depending on configuration with FAR sensors) or with output voltage a value of 0 V (or 5 V depending on configuration with FAR sensors, see under 7 Functional Description)

Flow at sensor: the green LED flashes, the analog output sends an analog value deviating from the zero flow conditions (see above).



11 Operation

(pay attention to 5.3 Operating Conditions and 5.6 Electrical Data)



12 Shut-down, dismantling

Before disconnecting the cable, please ensure that the supply voltage is switched off.

13 Inspection

Checking the LEDs, (see under 7 Functional Description, Self diagnosis)



14 Maintenance

Only use cleaning agents which dry without leaving any residue and which are compatible with the housing materials.

15 Calibration

The UFA and UVA transducers have an excellent long-term stability. However, it makes sense to have the instruments calibrated at certain intervals. The period between two calibrations depends on the individual operational conditions and the tolerable measurement error. Therefore, as a precaution, shorter calibration cycles should be chosen at the beginning. As an indication and under 'normal' operating conditions a calibration cycle of approx. 3-5 years applies.

Transducers must be returned to the manufacturer for calibration. Please refer to Section 17!

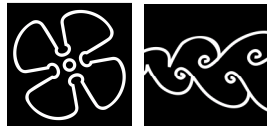

16 Troubleshooting

Fault	Cause	Troubleshooting
green LED does not light up	no power supply	check connecting cable, measure voltage at connecting terminals
	transducer electronics faulty	return to factory
yellow LED lights up, green LED does not flash despite flow, analog output = error (<3.6 mA or < -0.2V)	cable break or short-circuit	check terminals, check cable for continuity and replace if necessary
	transducer electronics or sensor faulty	return to factory
yellow LED lights up, green LED flashes with flow, analog output = error (<3.6 mA or < -0.2V)	parameter error	check parameter with UCOM software, save new checksum (or return to factory)
	transducer electronics faulty	return to factory
no measured value	sensor contaminated	clean sensor according to instructions
	coefficient set at 0.000	set coefficient at '1.000'
measured value too low	sensor contaminated	clean sensor according to instructions
	coefficient setting too low	set coefficient at '1.000'
	input/output section too short	change sensor position, improve flow conditions with a flow rectifier
	rotational flow	reposition sensor in flow direction, install flow rectifier
	vortex VA sensors: reduced acoustic coupling in the sensor elements as a result of intense vibration or powerful impact	return sensor to factory for performance test
	burden at current output is greater than specified in the Technical Data Sheet resulting in correct output values in the lower range and no longer increasing values at the top end of the measuring range	reduce resistance
	incorrect scaling of analog output	check setting and amend if necessary
measured value too high	coefficient set too high	set coefficient at '1.000'
	EMC problem	see under 6.3

17 Returns

No special measures necessary for UFA and UVA transducers.

When returning sensors, these should be cleaned thoroughly according to the instructions. A hazard warning or declaration of no objection must be supplied for substances which have been in contact with the sensor or possibly infiltrated the cavities in the sensor. If adhesion of hazardous substances cannot be ruled out, then detailed safety measures to be taken when handling the equipment must be itemised.

18 Disposal

The customer should assume the duty to dispose of the equipment at his own expense and according to statutory provisions (e.g. ElektroG in Germany).

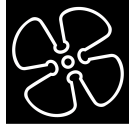

19 Replacement Parts

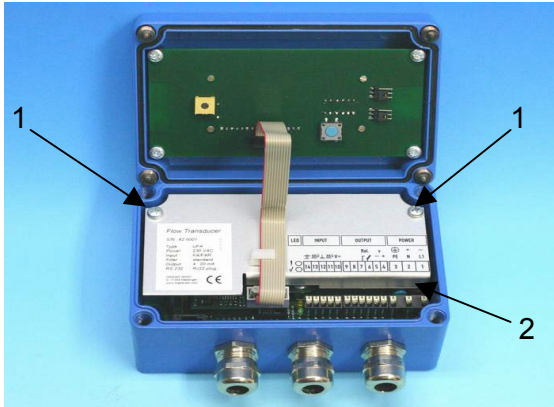

Fig. 3: Fuse TR5

Fuse TR5 (2) is situated in the base behind the power supply connecting terminals and is easily accessible by loosening the screws (1) to remove the cover plate:

for 230 V AC TR5-T 100 mA order no. e025/023
for 24 V DC TR5-T 500 mA order no. e025/024
for 12 V DC TR5-T 500 mA order no. e025/024



Always switch off before changing the fuse!

20 CE Declaration of Conformity, Manufacturer's Declaration

We herewith declare, that all appliances and sensors manufactured by us comply with the regulations of the EMC Directive 89/336/EEC, the Pressure Equipment Directive 97/23/EC and the Safety of Machinery Directive 89/37/EC.

The structural components comply with the following generic standards/directives:

- Low Voltage Directive (73/23/EEC)
- Safety of Machinery – Electrical Equipment of Machines (IEC 60204)
- Safety Requirements for Electrical Equipment for Measurement, Control and Laboratory Use (IEC 61010)
- Electrical Systems and Devices (VBG 4)
- Generic Standards, Immunity for Industrial Environments (IEC 61000-6-2)
- Generic Emission Standard, Industrial Environment (IEC 61000-6-4)

Itte / Steinhauser
HÖNTZSCH GmbH