



## Annex

# Operating Instructions Transducers UFA / UVA integrated in vane wheel sensors or vortex probes VA40 with connection housing

## Contents

- A1 Scope of Delivery**
  - A1.1 Description, Type Plates
- A2 Technical Specifications**
  - A2.1 Operating Conditions
  - A2.2 Housing and Connection
  - A2.3 Electrical Data
  - A2.4 Measurement Uncertainty
- A3 Installation**
  - A3.1 Block Diagram and Pin Assignment
  - A3.2 Wiring Diagrams
    - A3.2.1 Power supply
    - A3.2.2 Analog output v
    - A3.2.3 Digital output (Open-collector transistor)
    - A3.2.4 Interface RS232
    - A3.2.5 Optional LCD display
- A4 Functional Description**
- A5 Settings**
- A6 Initial Operation**
- A7 Operation**
- A8 Shut-down, Dismantling**
- A9 Inspection**
- A10 Troubleshooting**
- A11 Replacement Parts**



## A1 Scope of Delivery

- Transducer UFA or UVA integrated in the connection housing of the FA or VA flow sensors
- Operating Instructions Flow Sensor FA or VA,  
data sheet flow sensor FA or VA with integrated transducer UFA or UVA
- CD-ROM with PC configuration software UCOM (optional)
- Programming adapter GO 070 / RS232 for PC connection COM port (optional)
- USB adapter in addition to programming adapter GO 070 / RS232 (optional)
- Cable socket GO 070

Please check that everything listed in the Delivery Note / Technical Data Sheet is included in the delivery.

### A1.1 Description, Type Plates

One of the following type plates (or similar) can be found on the connection housing:

<b>VA Flow Sensor / UVA</b>	PS: 3 bar
S.No.: va40 1196 E100 °C	
T <sub>amb</sub> : -40...+80°C	T <sub>medium</sub> : -20...+100°C
Power ❶ 0 VDC ❷ +24 VDC	
Output ❸ GND ❹ $\bar{U}$ ❺ 4...20 mA	
RS232 ❻ RxD ❼ TxD	
www.hoentzsch.com	
CE	

<b>FA Flow Sensor / UFA</b>	PS: 6 bar
S.No.: md03 7377 350 °C	
T <sub>amb</sub> : -40...+80°C	T <sub>medium</sub> : -40...+350°C
Power ❶ 0 VDC ❷ +24 VDC	
Output ❸ GND ❹ $\bar{U}$ ❺ 4...20 mA	
RS232 ❻ RxD ❼ TxD	
www.hoentzsch.com	
CE	

<b>FA Di Flow Sensor / UFA</b>	PS: 10 bar
S.No.: ms20 1157-18 100°C	Di: 18,2 mm
T <sub>amb</sub> : -40...+80°C	T <sub>medium</sub> : -20...+100°C
Power ❶ 0 VDC ❷ +24 VDC	
Output ❸ GND ❹ $\bar{U}$ ❺ 4...20 mA	
RS232 ❻ RxD ❼ TxD	
www.hoentzsch.com	
CE	

VA Flow Sensor : vortex flow sensor VA40  
 FA Flow Sensor : vane wheel flow sensor  
 FA Di Flow Sensor : vane wheel measuring tube

UVA : transducer for vortex sensors VA  
 UFA : transducer for vane wheel sensors FA

PS : max. permissible pressure (absolute)

S.No. : serial number with max. temperature of the medium  
 Di : inside diameter Di of the measuring tube

T<sub>amb</sub> : ambient air temperature range -40...+80 °C  
 -5...+50 °C with 'LCD display' option

T<sub>medium</sub> : temperature range of medium

Pin assignment of cable socket GO 070:

Power	1	: 0 VDC	= supply voltage 0 VDC
	2	: +24 VDC	= supply voltage +24 VDC
Output	3	: GND	= reference potential
	4	: F	= digital output open-collector (internally connected to GND)
	5	: 4...20 mA	= current output 4-20 mA
RS232	6	: RxD	= serial interface
	7	: TxD	= serial interface
		(GND)	= reference potential

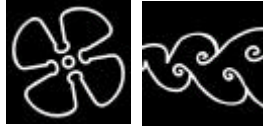

## A2 Technical Specifications



### A2.1 Operating Conditions

Ambient air temperature of connection housing when in use	: -40 ... +80 °C
with optional LCD display	: -5 ... +50 °C
protection class	: IP65
mounting attitude	: no restrictions

### A2.2 Housing and Connection

protection class	: housing IP65
material	: aluminium
external dimensions	: L/W/H = 80/80/60 mm
connection	: cable socket GO 070 with terminals for strands with cross-section 0.25 ... 1.0 mm <sup>2</sup>

### A2.3 Electrical Data

<b>Supply voltage, mains supply</b>	24 V DC (20 ... 27 V DC), power < 3 W
---	---------------------------------------

The mains supply is electrically isolated from the UFA/UVA outputs.

<b>Analog output</b>	: 4 ... 20 mA = 0 ... x m/s (or m <sup>3</sup> /h) 4 ... 20 mA = -x ... 0 ... +x m/s (or m <sup>3</sup> /h) with FAR function configurable. Terminal value x configurable / resistance max. 400 Ohm
----------------------	--

<b>Digital output</b>	: (open-collector transistor), max. 50 mA / 27 V DC, configurable as limit value v, quantity pulse or ±direction of flow (see under A4 Functional Description)
-----------------------	--

<b>RS232 interface</b>	: for connection with PC programme UCOM (see under A4 Functional Description) 9600 Baud, 8Bit, no parity, 2 stop bits, Xon/Xoff
------------------------	---

Accessible by unscrewing the housing cover:

<b>Connection for optional LCD display</b>	: flat ribbon cable with 10-pin cable socket <b>Do not plug in or out when live!</b>
--	---

### A2.4 Measurement Uncertainty

Recording the measurement frequency (at 1000 Hz)	: <0.1%
Analog output (terminal value)	: <0.15%
Linearity error	: <0.1%
Temperature coefficient	: <20 ppm/K (at 25 °K temperature difference equivalent to <0.05%)

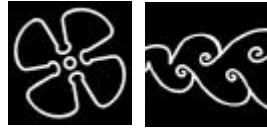

## A3 Installation

Authoritative here are the valid national regulations for installing electrical equipment, the general engineering regulations and these Operating Instructions.

### A3.1 Block Diagram and Pin Assignment

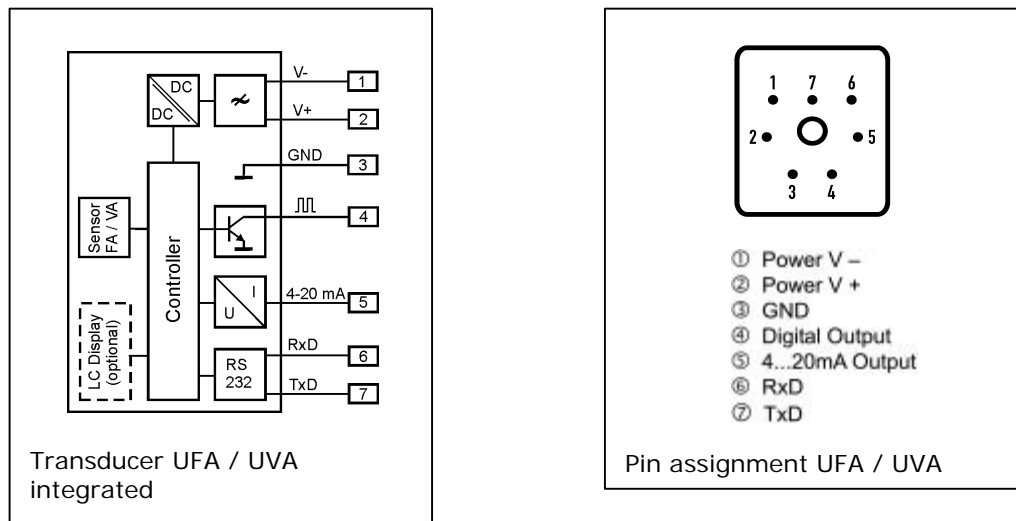

### A3.2 Wiring Diagrams

Electrical connection must be carried out according to the appropriate wiring diagram. **Faulty connection can cause damage to the electronics.**

Do not install or wire up the transducer under mains voltage. **Non-compliance can cause damage to the electronics.**

In this connection and depending on the configuration of the equipment, one of the following wiring diagrams must be taken into account. Wiring diagrams for measuring systems in customer-specific design will be supplied separately.



### A3.2.1 Power supply

Before connecting please check that the power supply is within the specification.  
The type plate with all relevant information can be found on the connection housing of the flow sensor.

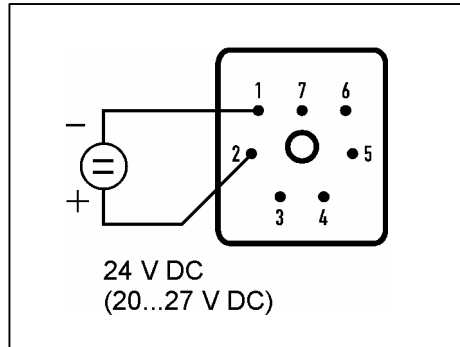

### A3.2.2 Analog output v

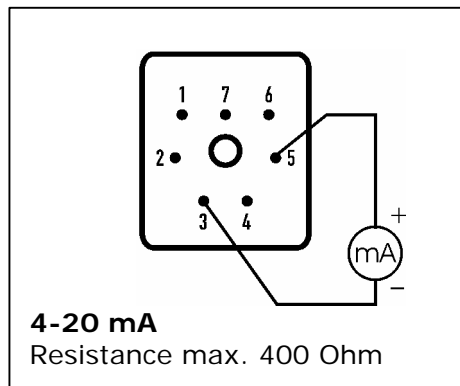

The terminal value of the analog output can be configured with the PC software UCOM via the RS232 interface. The factory-programmed values can be found in the accompanying documents.

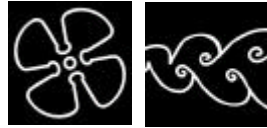

### A3.2.3 Digital output (open-collector transistor)

The digital output is an open-collector transistor output, internally connected to GND.

The function of the digital output and the corresponding setting parameter are configurable using the UCOM software via the RS232 interface. The factory-programmed settings can be found in the parameter printout.

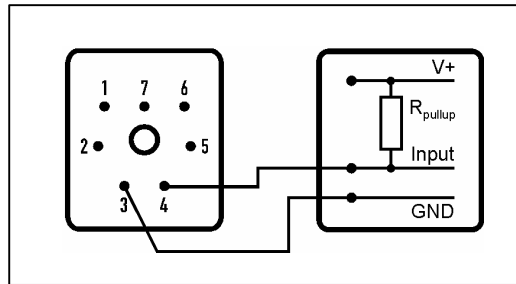

The reference potential terminal (3) of the UFA/UVA is connected to the GND terminal of the data logging. The open-collector transistor output (4) is connected to the input of the data logging, to which a pull-up resistor for internal supply voltage of the data logging must be connected (with 24 V as a rule 5...10 kOhm).

The limit values for the digital output are: max. 50 mA / max.27 VDC.

Note: If the same voltage source is used for the UFA/UVA as for the internal supply for the data logging, then the electrical isolation between the supply voltage and the UFA/UVA outputs is deactivated.

### A3.2.4 RS232 interface



Fig. 1: Programming adapter GO 70 / RS232 for UCOM software, connector PC Sub-D 9-pin, adaptor plug 230 VAC/24VDC and USB adapter

To connect the RS232 interface, plug the programming adapter into the UFA/UVA. The transducer is powered by the adapter.

Connection to a PC is via a COM port or with an optional USB adapter.



### A3.2.5 Optional LCD display



Fig. 2: optional LCD in the housing cover

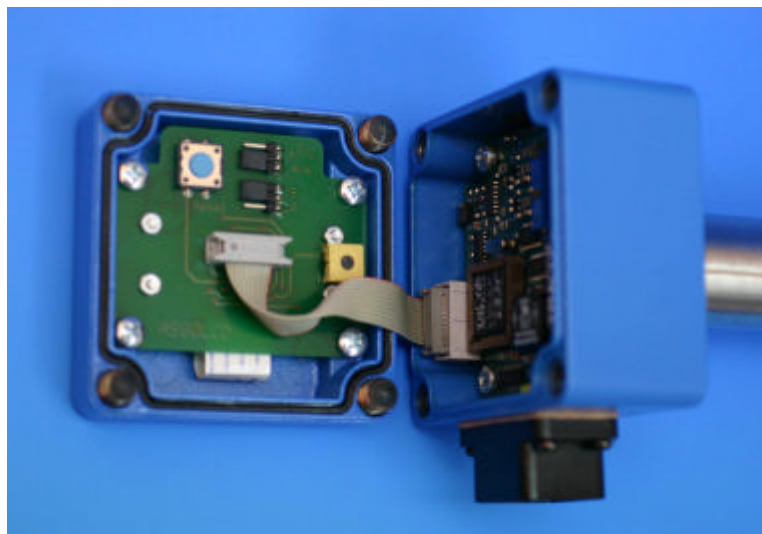

Fig. 3: LCD connection with cover open

**The flat ribbon cable with the 10-pin connector should not be plugged in or out when live! Risk of damage to equipment!**

Visible are the potentiometer for the LCD display, the reset button for the quantity counter, the jumpers m/s-m<sup>3</sup>/h and A-B (see under A4 Functional Description).



## A4 Functional Description

**UFA transducers** are designed for connecting to vane wheel probes FA and FAR (directional sensing) and vane wheel measuring tubes FA Di and FAR Di (directional sensing) for measuring flow velocity or flow rate of air/gases and water/liquids.

**UVA transducers** are designed for connecting to vortex sensors VA for measuring flow velocity or flow rate of air/gases.

The signal frequency generated from the flow sensor is converted to a linear **analog output signal 4-20 mA**. The analog terminal value is configurable.

When logging directional sensing data, the zero point can be selected in the middle of the analog range, or display of flow direction takes place with the aid of the digital output:

for FA and FAR*:	<b>4 ... 20 mA</b>	=	0 ... x m/s (or m <sup>3</sup> /h)
for FAR:	<b>4 ... 12 ... 20 mA</b>	=	-x ... 0...+x m/s (or m <sup>3</sup> /h)
for VA:	<b>4 ... 20 mA</b>	=	0 ... x m/s (or m <sup>3</sup> /h)

\* for FAR sensors configuration of the digital output (see under):  $\pm$ direction of flow

The actual velocity / actual flow rate can be converted to standard velocity / standard flow rate by entering the parameters 'temperature' and 'pressure'. Working temperature and pressure should be constant.

A **digital output** (open-collector transistor) can be configured for **1 of 3** different **functions**:

1. as **limit value** for the flow velocity or flow rate:  
 flow velocity < or = limit value: open-collector transistor inactive  
 flow velocity > limit value: open-collector transistor active
2. as **quantity pulse for** quantity measurement:  
 max. pulse repetition frequency 1 Hz per unit of volume,  
 configurable, e.g. 1 pulse per 1, 10 or 100 (norm)-m<sup>3</sup> or (norm)-litre  
 pulse duration 0.5 s (with FAR sensors: configurable for '+' or '-' amounts)
3. as  **$\pm$ direction of flow** \*\* (FAR sensors only):  
 +direction: open-collector transistor inactive  
 - direction: open-collector transistor active  
 \*\* analog output (see above) is then absolute value of flow only, without direction

### Self diagnosis according to NAMUR NE43:

**No error** : analog output = 4 mA (flow velocity = 0)  
 or : analog output > 4 mA (flow velocity > 0)

**Error** : analog output < 3.6 mA

Monitoring of power supply, data logging, sensor interface, parameter settings (see under A10: Troubleshooting)

### PC serial port RS232

for changing calibration data and setting parameters.

Connect programming adapter GO 070 (optional) to the UFA/UVA transducer, then plug in the adapter. Connect sub-D to the PC RS232 socket.

If PC connection is via USB, then an optional available USB / RS232 interface converter must be inserted.

Changes to the settings can now take place after starting the PC programme UCOM (optional) (see under A5: Settings).

### Optional LCD display in housing cover:

2 x 16 digit, character height 3 mm.





Display line 1 : instantaneous value velocity or flow rate.  
Display line 2 : 'quantity counter' or 'error code'.

Configuration (see Fig. 3, A3.2.5) via 2 jumper wrap connectors m/s-m<sup>3</sup>/h and A-B

**Display line 1:**

m/s-m <sup>3</sup> /h = m/s	and A-B = any:	velocity in (N)m/s *
m/s-m <sup>3</sup> /h = m <sup>3</sup> /h	and A-B = A:	flow rate in (N)m <sup>3</sup> /h
m/s-m <sup>3</sup> /h = m <sup>3</sup> /h	and A-B = B:	flow rate in (N)lt/h **

\* standard values (N) only when parameter 'switching v/NV' = 1 (see under A5)

\*\* only when diameter Di < 75.0 mm, otherwise display in (N)m<sup>3</sup>/h

**Display line 2:**

Quantity counter in m<sup>3</sup> with 0 ... 3 decimal places

(see under A5: parameter 'switching pulse m<sup>3</sup>(cbm) / l (litre)' and

parameter 'm<sup>3</sup> (cbm) / l (litre) per pulse' and

parameter 'decimal places quantity display')

with error : error 01 = parameter error

error 02 = sensor error

(see under A10: Troubleshooting)

Reset button in the housing cover: see Fig. 3

Reset the quantity counter by pressing the reset button for more than 3 seconds.

## A5 Settings

The following setting parameters can be read using the PC software UCOM and are also alterable.

The customer-specific settings are shown on the parameter print-out, which is included in the documents.

**Please find operation instructions PC software UCOM in document U385.**



## A6 Initial Operation

(Pay attention to A3.2.1 Power supply and A3.2.2 Analog output)

On connecting the supply voltage:

no flow at sensor: the analog output sends a value of 4 mA (or 12 mA depending on configuration with FAR sensors, see under A4 Functional Description)

flow at sensor: the analog output sends an analog value deviating from the zero flow conditions (see above).

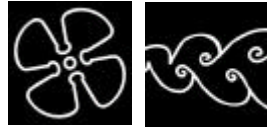

## **A7 Operation**

(Pay attention to A2.1 Operating Conditions and A2.3 Electrical Data)



## **A8 Shut-down, Dismantling**

Before disconnecting the cable, please ensure that the supply voltage is switched off.

## **A9 Inspection**

see under A4 Functional Description, Self diagnosis



## A10 Troubleshooting

Fault	Cause	Troubleshooting
<b>analog output = 0 mA</b>	no power supply	check connecting cable, measure voltage at connecting terminals
	transducer electronics faulty	return to factory
<b>analog output = error (&lt;3.6 mA)</b>	parameter error	check parameter using UCOM software, save new checksum (or return to factory)
	transducer electronics faulty	return to factory
<b>analog output = 4 mA, no measured value</b>	sensor contaminated	clean sensor according to instructions
	coefficient set at 0.000	set coefficient at '1.000'
<b>measured value too low</b>	sensor contaminated	clean sensor according to instructions
	coefficient setting too low	set coefficient at '1.000'
	input/output section too short	change sensor position, improve flow conditions with a flow rectifier
	rotational flow	reposition sensor in flow direction, install flow rectifier
	vortex VA sensors: reduced acoustic coupling in the sensor elements as a result of intense vibration or powerful impact	return sensor to factory for performance test
	burden at current output is greater than specified in the Technical Data Sheet resulting in correct output values in the lower range and no longer increasing values at the top end of the measuring range	reduce resistance
	incorrect scaling of analog output	check setting and amend if necessary
<b>measured value too high</b>	coefficient set too high	set coefficient at '1.000'
	EMC problem	see reference to electromagnetic compatibility (EMC)

## A11 Replacement Parts

Integrated transducers UFA /UVA have no replacement parts.  
An electronic self-restoring fuse is used.