

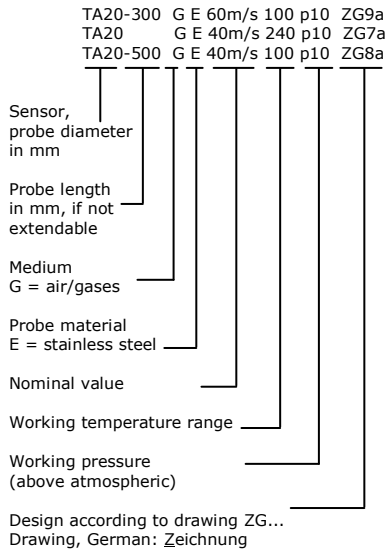

## Overview Probes TA20

Thermal Flow Sensors TA20: Probes, Accessories



### Extra charges for other models Art. no

Cable length for probes TA20...ZG7 longer than 2 m, basic price for each additional meter	TA20 KL
	TA20 KL-M

### Probe extension tubes

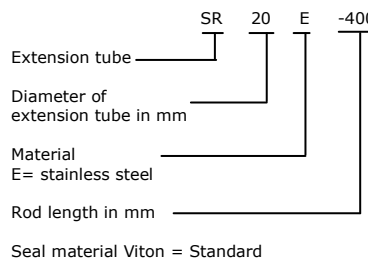

	Art. no
SFB20E-48 / G 1" ZG5 <sup>1)</sup>	B004/501
SFB20E-65 / F-DN50PN16 ZG1 <sup>2)</sup>	B004/101
SFS20E-44 / G 1" ZG5 <sup>3)</sup>	B004/500
SFS20E-60 / F-DN50PN16 ZG1	B004/100
SFB 20 E-200 / G 1" ZG13/056 <sup>1)</sup> Probe guide piece with ball valve G1" and chain safety device	B004/207

Probes of an exact length	Art. no
TA20-500GE 40m/s 100/p10 ZG8a	B013/203
TA20-300GE 40m/s 100/p10 ZG9a	B013/204
TA20-500GE 60m/s 100/p10 ZG8a	B013/205
TA20-300GE 60m/s 100/p10 ZG9a	B013/206
TA20-500GE 40m/s 240/p10 ZG8a	B013/207
TA20-300GE 40m/s 240/p10 ZG9a	B013/208
TA20-500GE 60m/s 240/p10 ZG8a	B013/209
TA20-300GE 60m/s 240/p10 ZG9a	B013/210

	Art. no
SR20E-400	B099/501

### Probe guide pieces SF...

SFB SF with clamping bush for unlimited repeated positioning of a probe at low subatmospheric and above atmospheric pressures

SFS SF with cutting ring fitting for single/one-off positioning of a probe at higher subatmospheric and above atmospheric pressures and higher temperatures

### Seal materials

® DuPont trademark

- 1) VITON, TEFLON clamping bush for +230 °C
- 2) TEFLON clamping bush for +230°C
- 3) VITON

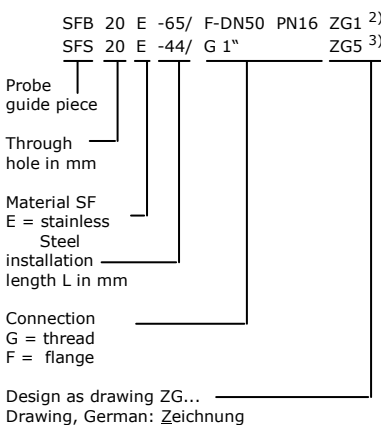

Transducers and accessories	Art. no
<b>U10 / 24 VDC</b> additional price transducer integrated in the connection housing AS80 with Output 4-20 mA with RS232/V24-Interface: only for transducer configuration with Pulse output for quantity measurement	A010/011
<b>U10 / 24 VDC / AS80</b> as separate transducer with Output 4-20 mA with RS232/V24-Interface: only for transducer configuration with Pulse output for quantity measurement	A010/013
Localized LCD display with quantity counter in the lid of the U10 housing. Display Nm <sup>3</sup> and Nm/s or Nm <sup>3</sup> /h	A010/007
Programming adapter U10acom	A010/004
CD ROM with software UCOM for configuring the transducer U10a using PC with WIN95/98 or higher	A010/052

Extra charges for other models	Art. no
Installation length different than the standard installation length, basic price	TA20 BL
for each additional 100 mm	TA20 BL-100M

Extendable Probes	Art. no
TA20GE 40m/s 100/p10 ZG7a	B013/211
TA20GE 40m/s 240/p10 ZG7a	B013/212
TA20GE 60m/s 100/p10 ZG7a	B013/213
TA20GE 60m/s 240/p10 ZG7a	B013/214
Direction Indicator RZ20	B099/952

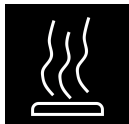

**Probes TA20**

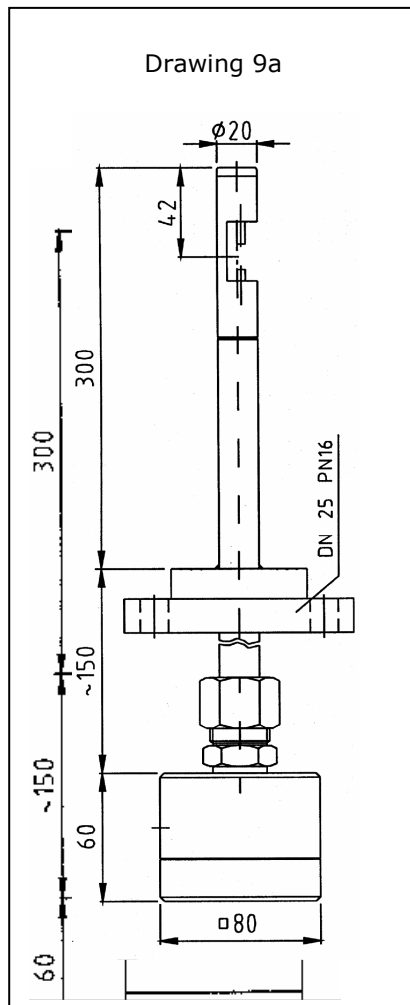
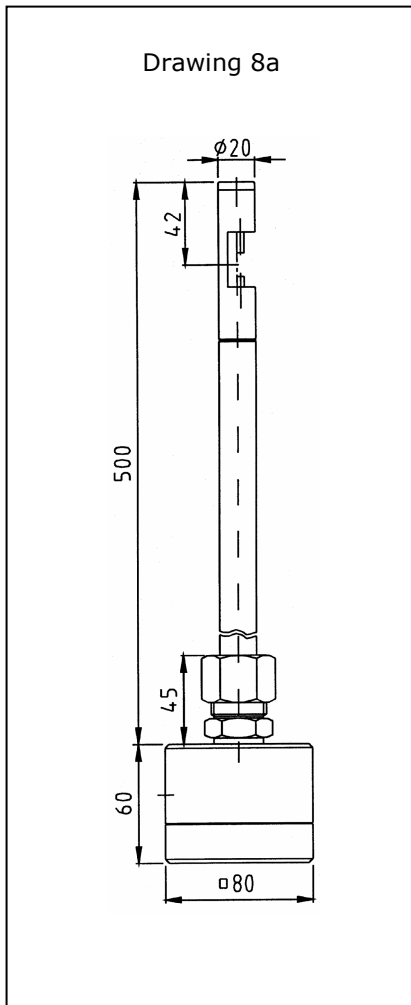
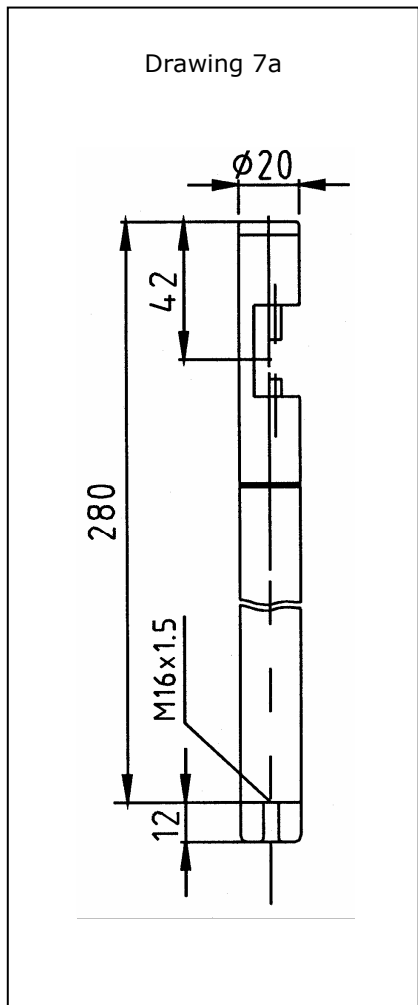

**Probe guide pieces SF**

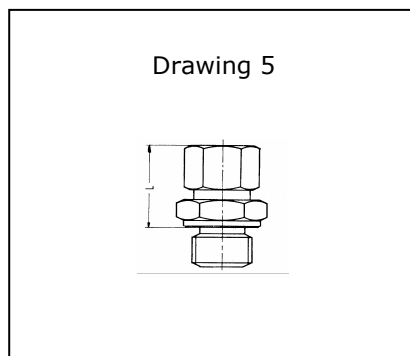
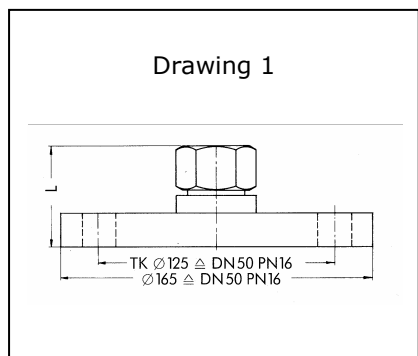

**Höntzsch GmbH**

P.O. Box 1324 D-71303 Waiblingen  
Gottlieb-Daimler-Straße 37  
D-71334 Waiblingen (Hegnach)  
Telephone 07151/1716-0  
Facsimile 07151/58402  
E-Mail info@hoentzsch.com  
Internet www.hoentzsch.com

**Effective as from Jan. 2009**  
Subject to alteration