



zertifiziert nach
ISO 9001 : 2000
certified quality

Transducer UVATP in AS102 Housing

Operating Instructions



Höntzsch GmbH

P. O. Box 1324 D-71303 Waiblingen
Gottlieb-Daimler-Straße 37
D-71334 Waiblingen (Hegnach)
Tel: 07151/1716-0
Fax: 07151/58402
E-Mail info@hoentzsch.com
Internet www.hoentzsch.com



Contents

- 1 Safety Symbols**
- 2 Proper Use in Compliance with Regulations**
- 3 Operating Safety**
- 4 Scope of Delivery**
 - 4.1 Description, Type Plates
- 5 Technical Specifications**
 - 5.1 Conformity with Standards
 - 5.2 Storage Conditions
 - 5.3 Operating Conditions
 - 5.4 Housing and Connectors
 - 5.5 Electrical Data
 - 5.6 Measurement Uncertainty VA TP DN ExactFlow II
- 6 Installation**
 - 6.1 Block Diagram
 - 6.2 Wiring Diagrams
 - 6.2.1 Cable shielding connection in the cable glands
 - 6.2.2 Power supply
 - 6.2.3 Temperature sensor Pt100
 - 6.2.4 Absolute pressure sensor 4...20 mA
 - 6.2.5 Analog outputs A1 and A2
 - 6.2.6 Relay output
 - 6.2.7 VA sensor input (separate transducers only)
 - 6.2.8 RS232 interface
 - 6.2.9 Optional LCD display
 - 6.3 Tips on Electromagnetic Compatibility (EMC)
 - 6.4 Connection Cable
- 7 Functional Description**
- 8 Settings**
- 9 Performance Check**
- 10 Initial Operation**
- 11 Operation**
- 12 Shut-down, Dismantling**
- 13 Inspection**
- 14 Maintenance**
- 15 Calibration**
- 16 Troubleshooting**
- 17 Returns**
- 18 Disposal**
- 19 Declaration of Conformity, Manufacturer's Declaration**



1 Safety symbols



Warning! Failure to observe the instructions can result in serious injury and damage to property!



Important notice!

Non-observance can result in serious damage to the equipment or performance restriction!

2 Proper Use according to Regulations



The UVATP transducer is for mass flow output by measuring the actual flow rate, the operating temperature and the absolute pressure. It is designed for industrial application.

The AS102 is an aluminium housing in protection class IP65.

The manufacturer is not liable for damage caused by improper use and/or non-compliance with the regulations.

Do not carry out any structural modifications to the transducers.

Always follow the instructions on the type plate, especially the information regarding supply voltage.

The UVATP can be integrated in the AS102 connection housing of measuring tubes VA TP DN ExactFlow II or is available as a separate transducer in AS102 housing.

3 Operating Safety



All steps described below must be carried out by qualified personnel only!

Please read the Operating Instructions carefully before unpacking the equipment!

Safety can only be guaranteed if the equipment is operated in accordance with the regulations.

Improper handling can result in serious injury and damage to property.

4 Scope of Delivery

- UVATP integrated in AS102 housing of VA TP DN ExactFlow II measuring tube or as separate transducer in AS102 housing
- LCD display 2x16 digit in the cover (optional)
- Operating Instructions, Data Sheet
- CD-ROM with PC configuration software UCOM (optional)
- Interface cable RS232 for PC COM port connection (optional)
- USB adapter in addition to the interface cable RS232 (optional)

Please check that everything listed in the Delivery Note / Technical Data Sheet is included in the delivery.

4.1 Description, Type Plates

Remove the cover to display one of the following type plates:

VA TP DN ExactFlow II		CE	
S/N. : 64 100	Input : VA Di 100	<small>e129/133</small> Höntzsch GmbH D-71334 Waiblingen www.hoentzsch.com	
Type : UVATP	RS 232 : RJ22 plug		
Power : 24 V DC			
Output A1 : precision 4 ... 20 mA			
Output A2 : fast 4 ... 20 mA			

VA TP DN ExactFlow II		CE	
S/N. : msvatp 40 115 E 80 °C	PS: 3 bar	<small>e129/133</small> Höntzsch GmbH D-71334 Waiblingen www.hoentzsch.com	
Type : UVATP	RS 232 : RJ22 plug		
Power : 24 V DC			
Output A1 : precision 4 ... 20 mA			
Output A2 : fast 4 ... 20 mA			

separate UVATP

integrated UVATP

S/N.	: ...	: serial number
Type	: UVATP	: for vortex VA measuring tubes, temperature, pressure
Power	: 24 V DC	: supply voltage 24 V direct voltage current
	: 12 V DC	: supply voltage 12 V direct voltage current
Output A1	: precision 4 ... 20 mA	: analog output with high precision current 4 ... 20 mA
	: precision 0 ... 10 V	: analog output with high precision voltage 0 ... 10V
Output A2	: fast 4 ... 20 mA	: analog output with short time constant current 4 ... 20 mA
	: fast 0 ... 10 V	: analog output with short time constant voltage 0 ... 10V
Input	: VADi	: for vortex VA measuring tubes (separate transducers only)
RS232	: RJ22 plug	: for serial PC interface

5 Technical Specifications

5.1 Conformity with Standards

The UVATP is manufactured according to the best available technology, is both safe and reliable and complies with the relevant regulations, EU directives and standards.

IEC 529 and EN 60 529	: protection class IP65
EN 61 000-6-2 / IEC77	: EMC



5.2 Storage Conditions

Storage temperature: -30 bis +70 °C



5.3 Operating Conditions

Ambient temperature during operation: -20 to +50 °C
 with optional LCD display: 0 to +50 °C
 protection class: IP65
 mounting attitude: no restrictions, preferably with cable bush facing down.



5.4 Housing and Connectors

Protection class	:	IP65
Material	:	aluminium
External dimensions	:	L/W/H = 150/100/80 mm
Cable entry point	:	nickel-plated brass screwed cable glands for cable diameter 5 ... 10 mm with cable shielding connections
Connections	:	'push in' PCB terminals for wire cross-section 0.14 ... 1.5 mm ² No tools necessary for core connection – simply insert strands (twisted or with end sleeve) into the terminal. To separate strands apply pressure to the terminal release spring using a pen or screwdriver.

5.5 Electrical Data

Supply voltage:

24 V DC	(20 ... 27 V DC),	power < 5 W
alternatively:		
12 V DC	(10 ... 17 V DC),	power < 5 W

The mains supply is electrically isolated from the UVATP inputs and outputs.

Input flow v/VA: (separate transducers only)

for Höntzsch vortex flow sensors VA as measuring tube (VA Di ...),
resolution 0.125 Hz.

Input temperature T:

for Pt100 temperature probe in 4-wire system,
acquisition time constant 2 s,
resolution 0.1 K.

Input pressure P:

for absolute pressure sensors 4 .. 20 mA, 12 .. 36 V in 2-wire system,
acquisition time constant 0.125 s,
resolution 1 hPa,
initial and terminal values configurable.

Analog outputs A1 and A2:

optionally, the analog outputs can be electrically isolated with each other and from the inputs using an additional isolating amplifier.

Analog output A1 precision:

high precision analog output,
update every 0.125 s,
time constant 4 s, with frequency hopping > 25 % 2 s,
time constants up to 99 s are configurable.

4 ... 20 mA = 0 ... x kg/h,
terminal value x configurable / resistance max. 500 Ohm,
alternatively:
0 ... 10 V = 0 ... x kg/h,
terminal value x configurable / impedance 1 kOhm

Analog output A2 fast:

analog output with short time constant,
update every 0.125 s, optionally 0.065 s
time constant 0.125 s

4 ... 20 mA = 0 ... x kg/h,
terminal value x configurable / resistance max. 500 Ohm,
alternatively:
0 ... 10 V = 0 ... x kg/h,
terminal value x configurable / impedance 1 kOhm

Relay: (potential-free normally open contact), max. 300 mA / 27 V DC,
configurable as limit value M or mass pulse
(see Section 7, Functional Description)

Optional raw signal output: BNC connector for VA frequency signal without linearization of the
Höntzsch vortex flow sensors with 5V level (TTL signal).

RS232 interface:

communication with UCOM (see Functional Description)
9600 Baud, 8Bit, no parity, 2 stop bits, Xon/Xoff

Connection for option LCD display:

flat ribbon cable with 10-pin connector
(do not connect or disconnect when power is on)

5.6 Measurement Uncertainty VA TP DN ExactFlow II

Gas mass flow at analog output A1 precision:	1% of measured value + 0.1 % of terminal value
Gas mass flow at analog output A2 fast:	2.5 % of measured value + 0.1 % of terminal value
Gas mass flow in optional LCD display:	1% of measured value + 0.1 % of terminal value

6 Installation



Authoritative here are the European installation regulations EN 60079-10: 1996 ff, as well as the general engineering regulations and these Operating Instructions.

6.1 Block Diagram

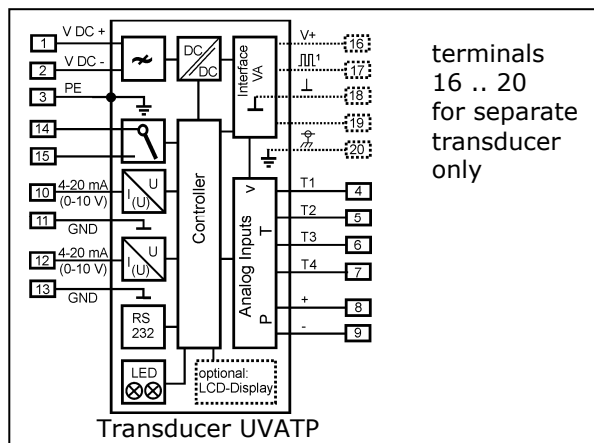

6.2 Wiring Diagrams



Electrical connection must be carried out according to the appropriate wiring diagram. **Faulty connection can cause damage to persons and destruction of the electronics.**

Do not install or wire up the transducer under mains voltage. **Non-compliance can cause damage to persons and destruction of the electronics.**

In this connection and depending on the configuration of the equipment, one of the following wiring diagrams must be observed. Wiring diagrams for measuring systems in customer-specific design will be supplied separately.

6.2.1 Cable shielding connection in the cable glands

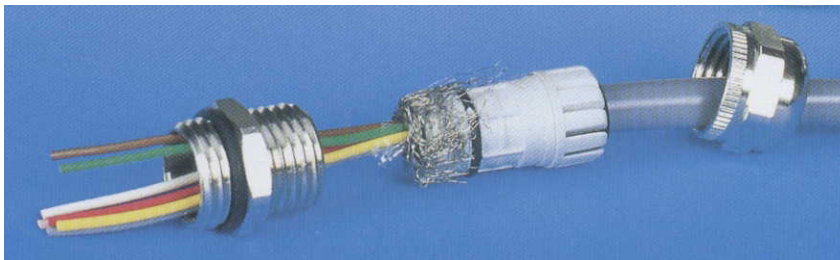

6.2.2 Power supply



Before connecting please check that the power supply is within the specification. Remove the housing cover of the UVATP to reveal the type plate with all relevant information.

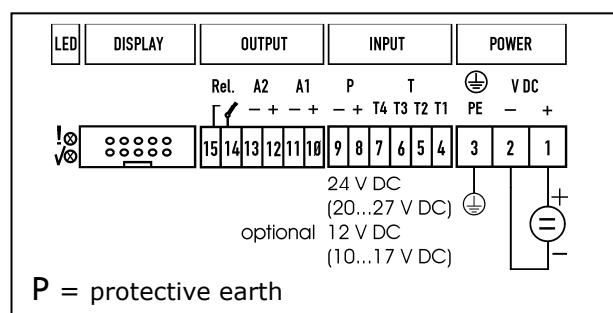

6.2.3 Temperature sensor Pt100

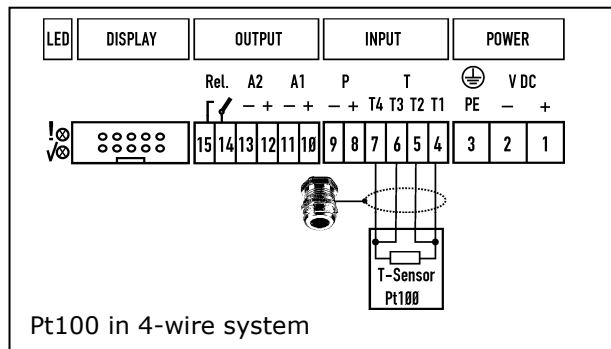

6.2.4 Absolute pressure sensor 4 ... 20 mA

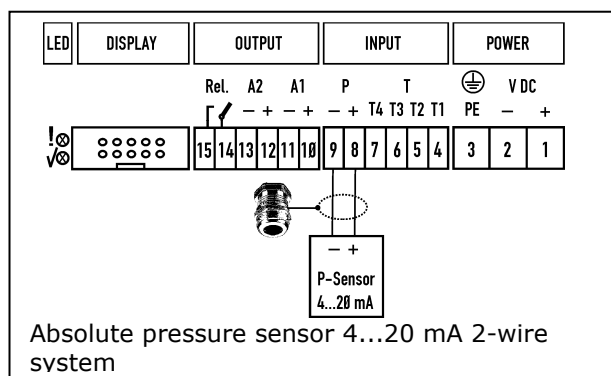

The initial value (4 mA) and the terminal value (20 mA) can be configured with the PC software UCOM via the RS232 interface. Customer-specific programmed values can be found in the accompanying documents.

6.2.5 Analog outputs A1 and A2

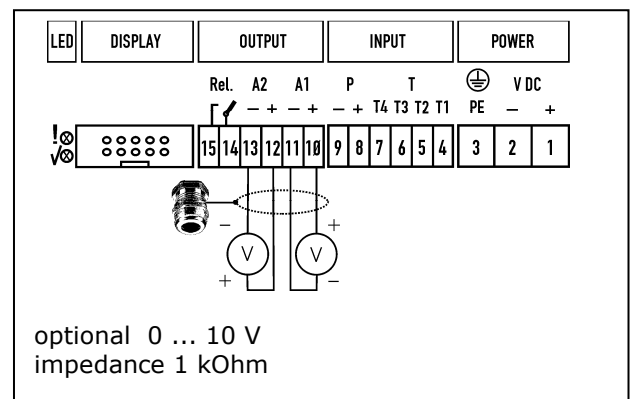
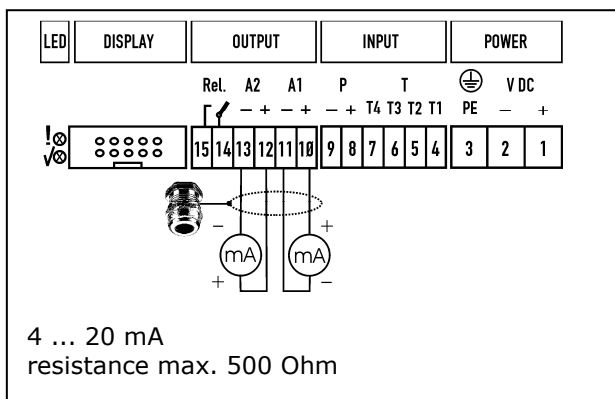

All relevant information can be found on the type plate.

The terminal value of the analog outputs can be configured with the PC software UCOM via the RS232 interface. Customer-specific programmed values can be found in the accompanying documents.

Output signals are electrically isolated from the power supply. Optionally, both 4 ... 20 mA outputs can be isolated with each other and from the inputs using an additional isolating amplifier.

6.2.6 Relay output

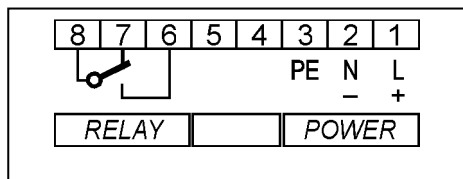

The normally open contact is shown in rest position (relay coil off).

The function of the relay output and the corresponding setting parameter can be configured with the PC software UCOM via the RS232 interface. Customer-specific settings can be found in the documentation.

6.2.7 VA sensor input (separate transducers only)

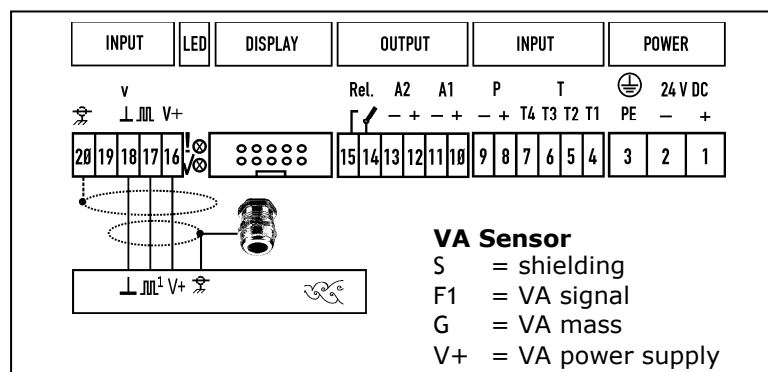

In the case of sensor housings with screwed cable glands, the shielding of the sensor connection cable is connected in the cable glands.

6.2.8 RS232 interface



Abb. 1: PC connection with RJ22 plug with cover open

The RS232 interface connection is below left next to the connecting terminals. The RJ22 plug of the PC connecting cable is plugged in to the socket (see Fig. 1). PC connection follows at a COM port or using an optional USB adapter.

6.2.9 Optional LCD display



Abb. 2: LCD display connection with cover open

The flat ribbon cable with 10-pin connector should not be plugged in or out when live! Risk to persons and equipment!

Visible are the readout potentiometer for the LCD display contrast and the ST1 and ST2 jumpers (see under 7 – Functional Description).



6.3 Tips on Electromagnetic Compatibility (EMC)

- Keep all connecting cables **as short as possible**.
- With **cable routes longer than 30 m** or with strong electromagnetic disturbance along the cable route between sensor and evaluation unit, the use of a **double-shielded cable** is recommended: to do this lay inner shielding to one side of the evaluation unit and lay outer shielding on both sides over a large area with low-impedance connection on the sensor and evaluation unit or on the control cabinet
- **Do not loop** the cable!
- **Lay free strands** at both ends **on protection potential!**
- **Lay cables as close to ground as possible**, as for example side panels, mounting plates or steel girders.
- When using **frequency converters** there is a risk of **interference by HF transient emissions**. Therefore, decouple the power input of the frequency converter via an interference filter against active transient emissions. This also increases the passive interference resistance of the equipment.
- Use only shielded motor cables with shield support on both sides between **motors** and **converters**.
- **spatially separate cables which emit interference** from measuring lines and evaluation units. If necessary, lay measuring lines in a metallic tubular cable protection.
- Ensure large area and low resistance connection of **metallic parts in control cabinets**, such as subracks with control electronics or subplates.
- Relays, contactors and electro valves in the **same electric circuit**, are to be wired with **spark quenching combinations** or surge-limiting components.



- Lay the shielding of **analog signal lines** on one side only – preferably on the evaluation unit - and low resistive. Twist unshielded lines to counteract balanced interference to source terminals.
- Lay the shielding of **digital signal lines** on both sides across a wide area. In the case of potential differences between these points it is advisable to lay a separate **equipotential bonding conductor**.
- Preferably provide shielded connector for **connections to connector cable separation points**.
If using **terminals**, these should be in a HF-shielded housing, in which EMC-compatible cable bushes should be used. Connect outer shielding of the connector cables to the cable bush.

6.4 Connection cable

For connecting between sensor and separate transducer UVATP LiYCY cable with simple copper braiding screen can be used if the cable path is short and there is marginal electromagnetic interference. Over longer distances or with a high rate of electromagnetic interference, a double-screened cable of type LiYCY-CY should be used.

VA sensor 3 x 0.25 mm²
Max. permissible conductor resistance per strand is 15 Ohm.

Conductor resistances for finely stranded conductors:

approx. 79 Ohm/km	with wire cross section 0.25 mm ²
approx. 39 Ohm/km	with wire cross section 0.50 mm ²
approx. 26 Ohm/km	with wire cross section 0.75 mm ²

7 Functional Description

UVATP transducers are for mass flow output by measuring the actual flow rate, the operating temperature and the absolute pressure.

The signal frequency coming from the flow sensor and proportional to the actual flow rate signal is converted into a linear **analog output signal** 4-20 mA or 0-10 V taking temperature and absolute pressure into account (see Electrical Data, 5.5).

The analog terminal value is configurable.

alternatively:	4 ... 20 mA	=	0 ... x kg/h
	0 ... 10 V	=	0 ... x kg/h

The **relay output** (normally open contact) can be configured for **1 of 2** different **functions**:

1. as **limit value** for the mass flow:
 - mass flow < or = limit value: relay contact in rest position
 - mass flow > limit value: relay contact in operating position
2. as **quantity pulse** for the quantity measurement:
 - max. pulse repetition frequency 1 Hz per mass unit, configurable, e. g. 1 pulse per 1, 10 or 100 kg
 - pulse duration 0.5 s

In the case of measuring systems with a maximum mass flow rate up to 6500 kg/h, the output in the display and at the analog output follows with a decimal place (e.g. 6489.7 kg/h) and with higher maximum mass flow rate without a decimal place (e.g. 24585 kg/h).



Self diagnosis according to NAMUR NE43 specifications:

No error: yellow LED off
 green LED on (actual flow rate = 0)
 or
 green LED flashes (actual flow rate > 0)
Error: yellow LED on and at the analog output
 - output 4-20 mA : < 3.6 mA
 - output 0-10 V : < -0.2 V

The following are monitored: power supply, data logging, sensor interface, parameter settings
(see under 16: Troubleshooting)

PC serial port RS232:

for modification of calibration data and setting parameters.

For this purpose remove cover.

Plug PC connector cable (optional) with RJ22 into the socket in the transducer (see Fig. 1, Page 9).
Connect other end of cable to PC COM port.

If a USB connection is required, then an optional USB / RS232 interface converter must be inserted.
Changes to the settings can now take place after starting the PC programme UCOM (optional)

optional LCD display in housing cover:

2 x 16 digit, character height 5.5 mm

Display line 1: instantaneous value actual flow rate or mass flow.

Display line 2: temperature and absolute pressure.

Configuration (see Fig.2, Page 10) via jumper wrap connector ST2

Display line 1:

ST2 = A: actual flow rate in m³/h

ST2 = B: mass flow in kg/h

Switch-over from mass flow rate to standard flow rate in the display and at the analog outputs is via
jumper ST1

Display 1st line and analog outputs

ST1 = m³/h standard flow rate in Nm³/h

ST1 = m/s mass flow rate in kg/h

8 Settings

The setting parameters are readable and alterable using the UCOM software.
Customer-specific settings can be found in the accompanying documents.

For Operating Instructions Software UCOM see Document U385.



9 Performance Check

Sensor not connected

(Please pay attention to 6.2.2 Power supply and 6.2.5 Analog outputs)

After connecting the supply voltage the green and yellow LED light up.

The analog output provides a value between 3.4 mA and 3.6 mA with current output or between -0.3 V and -0.2 V with voltage output.



10 Initial Operation

Sensor connected

(Please pay attention to 6.2.2 Power supply, 6.2.3 and 6.2.4 sensor inputs and 6.2.5 Analog outputs)

After connecting the supply voltage the green LED lights up and the yellow LED is off.

No flow at sensor: the green LED is permanently on; the analog output provides a value of 4 mA with current output and 0 V with voltage output.

Flow at sensor: the green LED flashes; the analog output supplies an analog value deviating from the zero flow conditions (see above).



11 Operation

(Please pay attention to 5.3 Operating Conditions and 5.5 Electrical Data)



12 Shut-down, Dismantling

Before disconnecting the cable, please ensure that the supply voltage is switched off before disconnecting the cable.

13 Inspection

Check the LEDs, (see under 7 Functional Description, Self diagnosis)



14 Maintenance

Use only residue-free drying cleaning agents which are compatible with the housing materials.

15 Calibration

The UVATP has an excellent long-term stability. However, it makes sense to have it calibrated at regular intervals. The time lapse between calibrations depends on the individual operating conditions and the tolerable measurement error. Therefore, as a precautionary measure, shorter calibration cycles are recommended in the beginning. As a general rule and under 'normal' operating conditions we suggest a cycle of approx. 3 - 5 years.

The transducer must be returned to the manufacturer for calibration (see under 17).



16 Troubleshooting

Fault	Cause	Troubleshooting
green LED does not light up	no power supply	check connecting cable; measure voltage at connecting terminals
	transducer electronics faulty	return to factory
green LED does not flash despite flow	VA sensor cable break or short circuit	check terminals; check cable for continuity and replace if necessary
	transducer electronics or sensor faulty	return to factory
yellow LED lights up, green LED flashes with flow, analog output = error (<3.6 mA or < -0.2V)	parameter error	check parameter with UCOM software; save new checksum (or return to factory)
	temperature probe or connection cable faulty	check terminals; check cable for continuity and replace if necessary or return to factory
	absolute pressure sensor or cable faulty	check terminals; check cable for continuity and replace if necessary or return to factory
	transducer electronics faulty	return to factory
no measured value	sensor contaminated	clean sensor according to instructions
	coefficient set at 0.000	set coefficient at '1.000' with volumetrically calibrated measuring tubes
measured value too low	sensor contaminated	clean sensor according to instructions
	coefficient setting too low	set coefficient at '1.000' with volumetrically calibrated measuring tubes
	input/output section too short	change sensor position, improve flow conditions with a flow rectifier
	rotational flow	reposition sensor in flow direction, install flow rectifier
	reduced acoustic coupling in the sensor elements as a result of intense vibration or powerful impact	return sensor to factory for performance test
	burden at current output greater than specified in the Technical Data Sheet resulting in correct output values in the lower range and no longer increasing values at the top end of the measuring range	reduce resistance
	incorrect scaling of analog output	check setting and amend if necessary
measured value too high	coefficient setting too high	set coefficient at '1.000' with volumetrically calibrated measuring tubes
	incorrect scaling of analog output	check setting and amend if necessary
	EMC problem	see 6.3



17 Returns

No special measures need to be taken for non-integrated UVATP transducers.

Clean associated sensors or those with integrated transducer thoroughly before returning to the manufacturer (see cleaning instructions for the sensor).

A hazard warning or declaration of harmlessness for substances which have come into contact with or infiltrated the sensor, must be submitted with all returns. If adhesion of hazardous substances on the surface of the equipment cannot be ruled out, a detailed description of safety measures to be taken when handling the equipment must be submitted.

18 Disposal

The customer should assume the duty to dispose of the equipment at his own expense and according to statutory provisions (e.g. ElektroG in Germany).

19 Declaration of Conformity, Manufacturer's Declaration

We herewith declare, that all appliances and sensors manufactured by us comply with the regulations of the EMC Directive 89/336/EEC, the Pressure Equipment Directive 97/23/EC and the Safety of Machinery Directive 89/37/EC.

The structural components comply with the following generic standards/directives:

- Low Voltage Directive (73/23/EEC)
- Safety of Machinery – Electrical Equipment of Machines (IEC 60204)
- Safety Requirements for Electrical Equipment for Measurement, Control and Laboratory Use (IEC 61010)
- Electrical Systems and Devices (VBG 4)
- Generic Standards, Immunity for Industrial Environments (IEC 61000-6-2)
- Generic Emission Standard, Industrial Environment (IEC 61000-6-4)

Itte / Steinhauser
HÖNTZSCH GmbH